

# WATEROUS

Form Number: F-2904

Issue Date: Sept 8, 2020

## Control Air Circuit Calibration Instructions

70-35-GP with Reciprocating Air Compressor

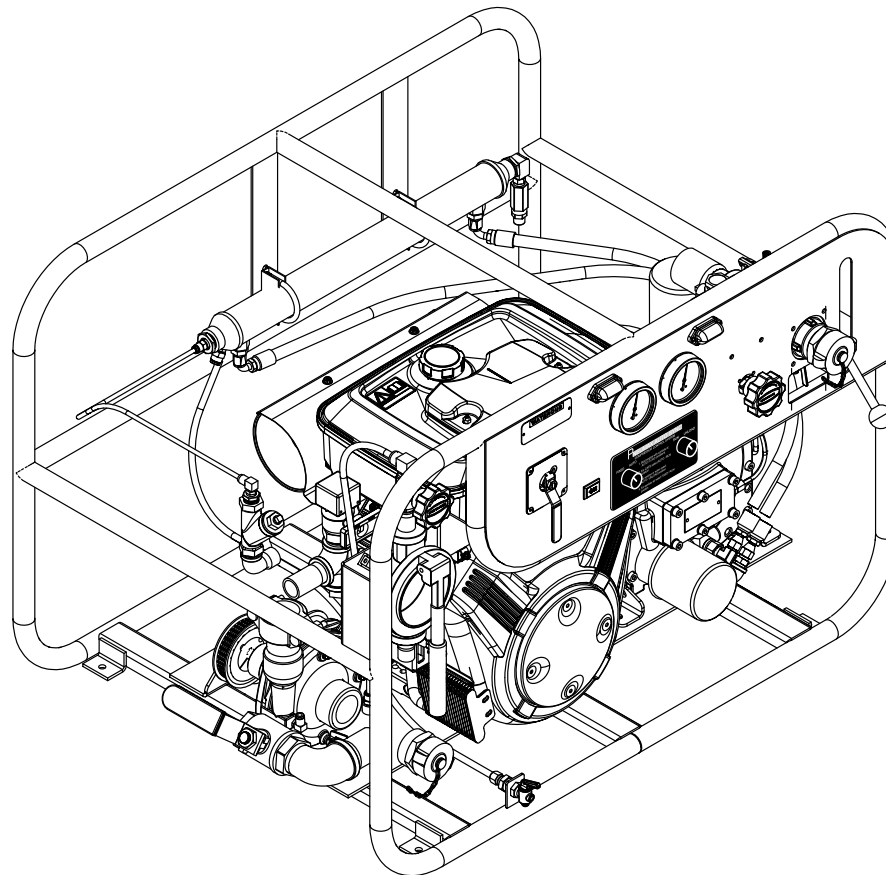

Waterous Company • 125 Hardman Avenue South • South Saint Paul, MN 55075 • (651) 450-5000

[www.waterousco.com](http://www.waterousco.com)



# Table of Contents

---

<b>Safety</b>	<b>4</b>
Safety Precautions	4
<b>Introduction</b>	<b>5</b>
Using this Document	5
Viewing the Document Electronically	5
Printing the Document	5
<b>Product Overview</b>	<b>6</b>
Air Inlet-Trim Valve	6
Fixed/Manual Pressure Regulator	6
Balance Valve	7
<b>Calibration</b>	<b>8</b>
Preparing for Calibration	8
Modifying the Equipment	8
Calibrating the System—Unload Mode	9
Calibrating the System—Fixed Mode	10
Calibrating the System—Auto Mode	11

## Safety Precautions

- Read and understand all the associated documentation before you begin the calibration procedure.
- Read and understand all the notices and safety precautions.
- Be aware that these instructions are only guidelines and are not meant to be definitive. Contact Waterous when you have questions about the calibration procedure.
- Do not perform the calibration if you are not familiar with the tools and skills needed to safely perform the procedure.
- Do not operate the equipment when safety guards are removed.
- Do not modify the equipment.

### **WARNING**

#### **Moving Parts**

- Rotating parts can cause severe injury or death
- Do not enter reach into or enter the compartment when the equipment is on.

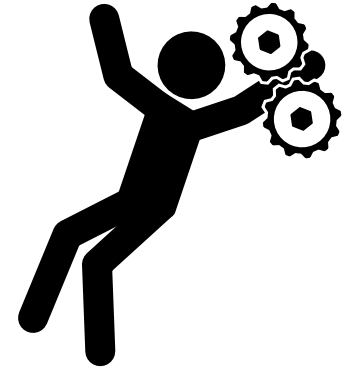

### **NOTICE**

#### **Modification**

- Modifying the equipment can damage components and void your warranty.
- Do not modify the system or any of its components.

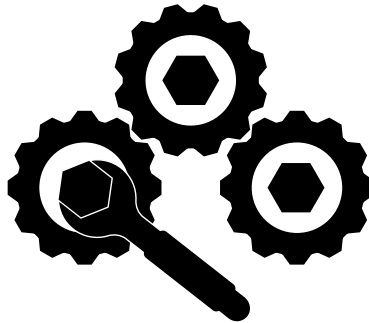

### **WARNING**

#### **Hot Surface**

- Hot surface can burn you.
- Components reach high temperatures during operation--wear protective equipment when making adjustments.

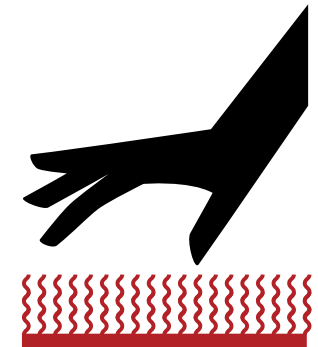

Use this document to calibrate your Waterous equipment. Understand the following conditions before continuing with the document:

- The illustrations in this document are intended to convey concepts. Do not use the illustrations to determine physical attributes, placement, or proportion.
- Understand that your application may require additional steps, that are not described in the illustrations or instructions, to perform the calibration.
- The procedures described in this document are intended to be performed by a person or persons with the necessary skills and knowledge to perform similar procedures. Contact Waterous for more information.
- The information in this document is subject to change without notice.

This document is divided into the following sections:

#### SAFETY

This section describes general precautions and alert symbols that are in this document.

#### INTRODUCTION

This section is an overview of the document.

#### PRODUCT OVERVIEW

This section describes the parts used to calibrate the system.

#### CALIBRATION

This section describes the calibration procedures.

## Using this Document

---

Use the guidelines below when viewing this document.

### Viewing the Document Electronically

---

- View this document in landscape orientation.
- Use the table of contents to navigate directly to that section.

### Printing the Document

---

- The document is viewed the best when printed in color.
- The *print on both sides* and *flip on long edge* features can provide the best results.
- Use a 3-ring binder to store the document.

## Air Inlet-Trim Valve

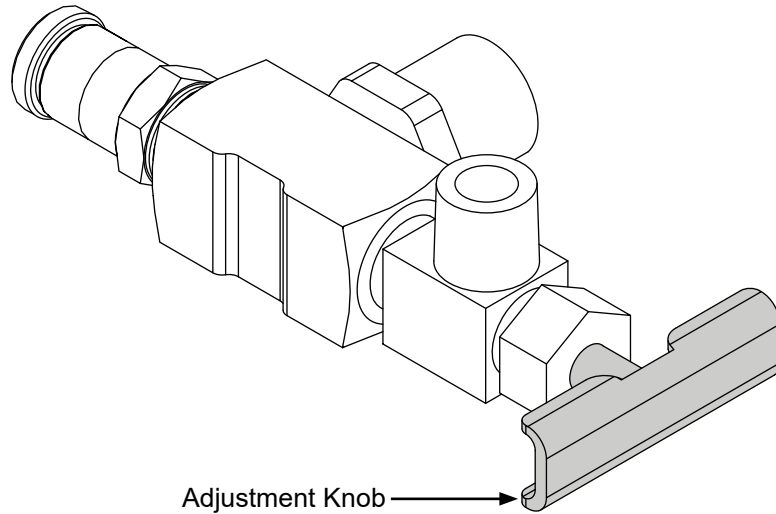

## Fixed/Manual Pressure Regulator

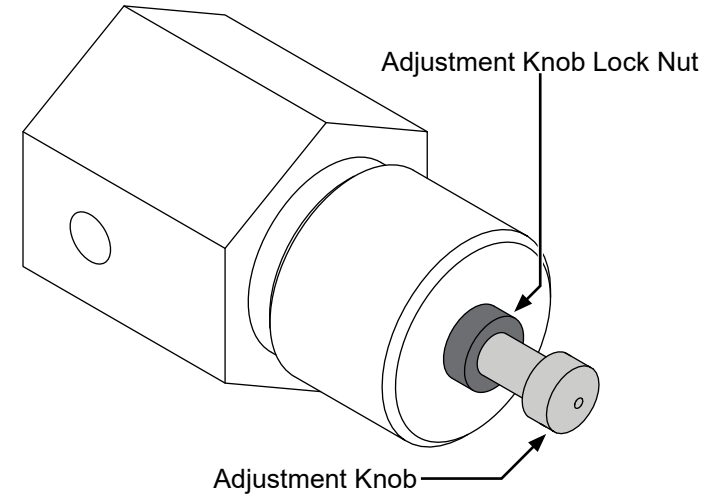

### **WARNING**

#### Hot Surface

- Hot surface can burn you.
- Components reach high temperatures during operation--wear protective equipment when making adjustments.

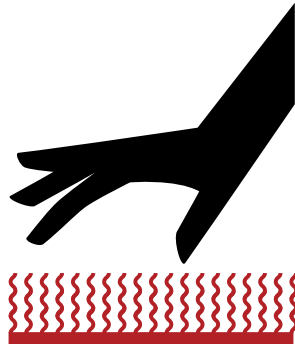

*The operating temperature of the components require you to wear protective gear to make the adjustments.*

### **WARNING**

#### Hot Surface

- Hot surface can burn you.
- Components reach high temperatures during operation--wear protective equipment when making adjustments.

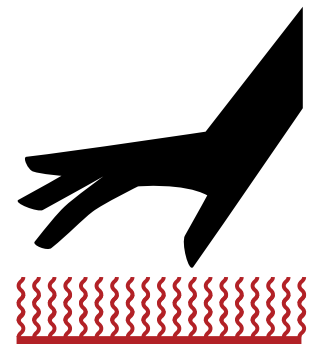

*The operating temperature of the components require you to wear protective gear to make the adjustments.*

## Balance Valve

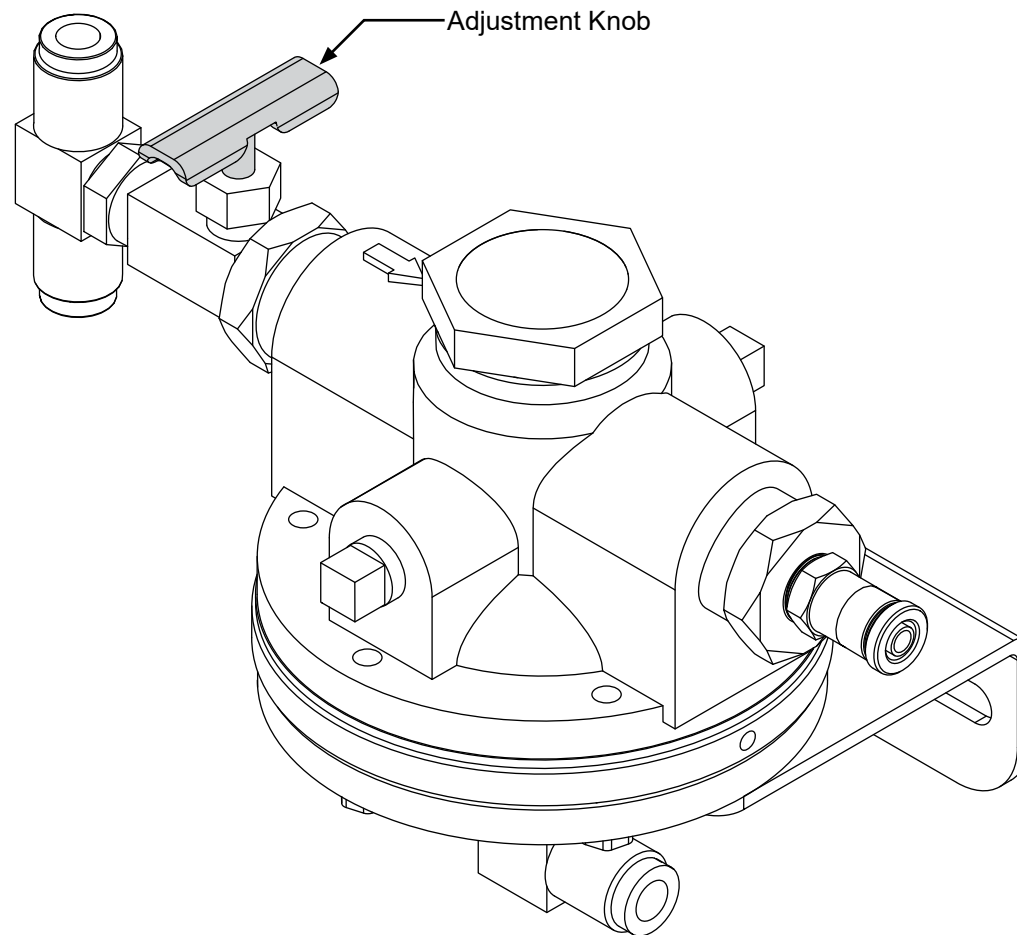

## Preparing for Calibration

Use the following guidelines before, during, and after the calibration procedure.

- Read and understand all the instructions before you begin the calibration procedure.
- Prepare a suitable, well-lit area, and gather all the necessary tools before you begin the calibration procedure.
- Make sure that you bring all fluids to operating levels before you begin the calibration procedure.

## Modifying the Equipment

This equipment is intended to operate as designed. Do not remove, modify, or change the components in the system. Doing so will void the warranty. Contact Waterous for more information.

# NOTICE

## Modification

- **Modifying the equipment can damage components and void your warranty.**
- **Do not modify the system or any of its components.**

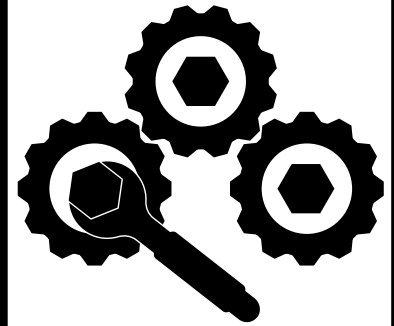

*Do not modify the system or any components. Doing so will void your warranty.*



## Calibrating the System—Unload Mode

**1**

### WARNING

### Moving Parts

- Rotating parts can cause severe injury or death
- Do not enter reach into or enter the compartment when the equipment is on.

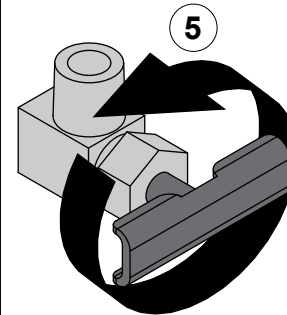
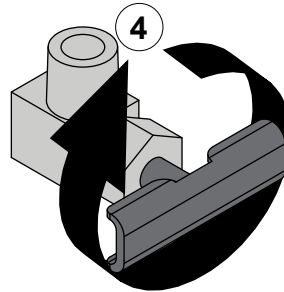

## PNEUMAX AUTO SYNC

COMPRESSOR CONTROL SYSTEM

FIXED
AUTO
RUN
UNLOAD

1. Start engine with controls at AUTO / LOAD positions.
2. For CAFS select AUTO / RUN position.
3. For solution or water select AUTO / UNLOAD position.
4. For auxiliary air select FIXED / RUN position.

2

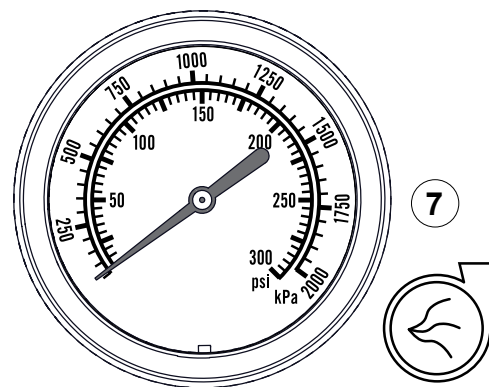
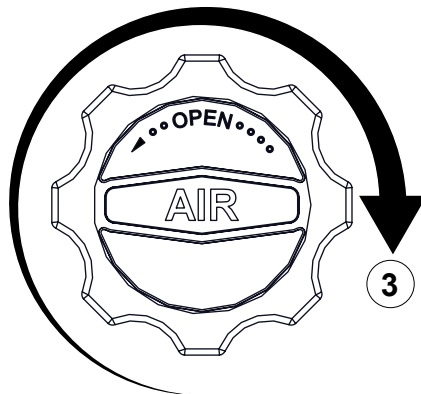
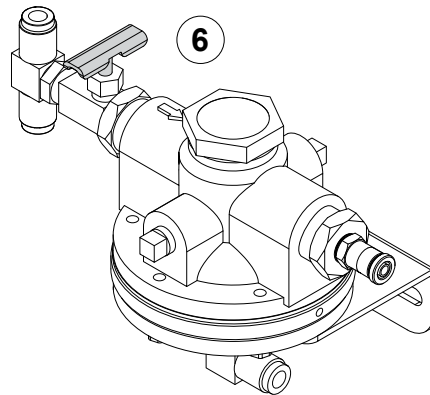

Use the illustrations and instructions to adjust the unload mode operation.

**Note:** When operating the system:

- Always start the system in auto or unload mode.
- The operating temperature of the components require you to wear protective gear to make the adjustments.

- 1 Use caution when performing this procedure.
- 2 Set the auto-sync control to the *UNLOAD* position.
- 3 Make sure that you close all air discharges before beginning the calibration.
- 4 Locate the air inlet trim valve near the compressor air inlet and turn it clockwise until fully closed.
- 5 Turn the valve clockwise until it is close. Then turn it counterclockwise 1/2 to 3/4 turns from closed.
- 6 Locate the trim valve on the balance valve and turn it counterclockwise until it is fully open.
- 7 Establish flow through the fire pump. The main air pressure gauge should read 0 psi (0 bar).

## Calibrating the System—Fixed Mode

**1**

**! WARNING**

**Moving Parts**

- Rotating parts can cause severe injury or death
- Do not enter reach into or enter the compartment when the equipment is on.

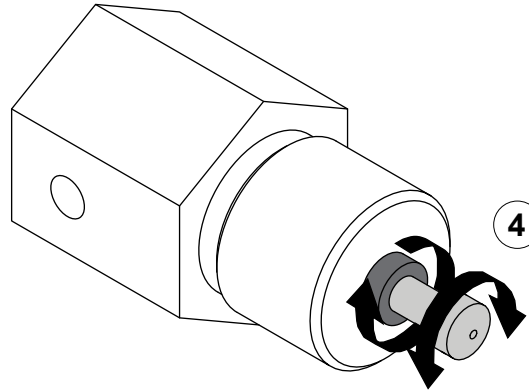
Use the illustrations and instructions to adjust the fixed mode operation.

**Note:** When operating the system:

- Always start the system in auto or unload mode.
- The operating temperature of the components require you to wear protective gear to make the adjustments.

1 Use caution when performing this procedure.

2 Set the auto-sync controls to the *FIXED* and *RUN* positions.

3 After the air pressure stabilizes, loosen the adjustment locknut on the pressure regulator located on the back of the operator's panel.

4 Use the adjustment screw to achieve an operating pressure of 125–130 psi.

- Clockwise increases the air pressure.
- Counterclockwise decreases the pressure.

Tighten the adjustment locknut once operating pressure is achieved.

**Note:** Make partial turns and allow time for the adjustment to affect the pressure.

5 Vary the engine speed to make sure that the pressure remains fixed around 130 psi.

**Note:** Repeat the adjustment procedure if necessary.

6 Toggle the auto-sync control from *RUN* to *UNLOAD* to *RUN* again to verify the fixed mode operation.

**Note:** The pressure may overshoot the target pressure before settling to the target pressure.

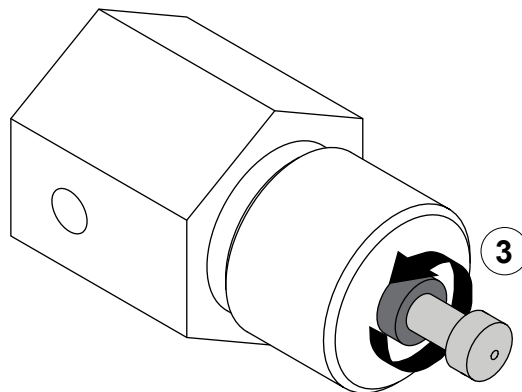
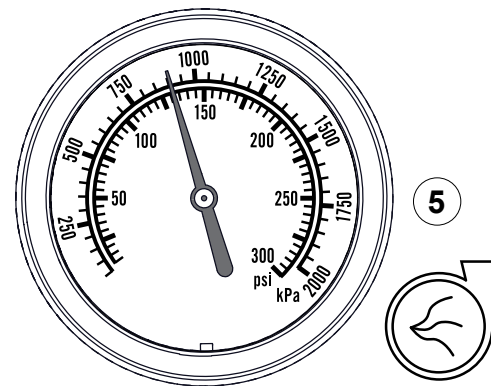

## Calibrating the System—Auto Mode

1



2

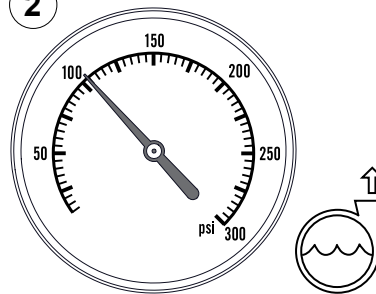

Use the illustrations and instructions to adjust the auto mode. Make sure that you have the fixed mode is operating properly before calibrating auto mode. Auto mode synchronizes the air pressure with the water pressure. The system raises or lowers the air pressure automatically as you raise or lower the static water pressure.

**Note:** When operating the system:

- Always start the system in auto or unload mode.
- The operating temperature of the components require you to wear protective gear to make the adjustments.



1 Use caution when performing this procedure.

2 Make sure that the water pump is operating at 100 psi (10.3 bar) at the discharge with minimal flow.

3 Set the auto-sync controls to the *AUTO* and *RUN* positions.

4 Make sure that the air pressure is equal to or up to 5% higher than the static water pressure. Raise and lower the static water pressure and verify that the air pressure tracks with the static water pressure.

4

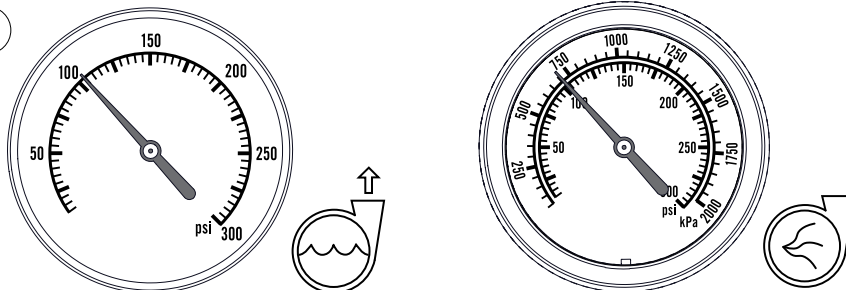

## Calibrating the System—Auto Mode Continued

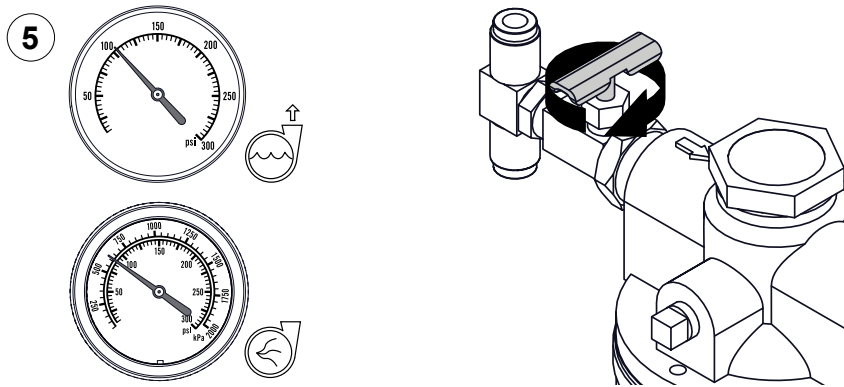

Use the illustrations and instructions to complete the auto mode setup.

**Note:** When operating the system:

- Always start the system in auto or unload mode.
- The operating temperature of the components require you to wear protective gear to make the adjustments.

- 5 If the air pressure is lower than the water pressure, turn the balance trim valve 1 full turn clockwise. After the adjustment takes effect, compare the air and water pressure. Repeat this step until air pressure is equal to, or 5% more than the water pressure.

Make sure that the auto-sync system raises and lowers the air pressure automatically as you raise or lower the static water pressure.

**WATEROUS**

Waterous Company  
125 Hardman Avenue South  
South Saint Paul, MN 55075  
(651) 450-5000  
[www.waterousco.com](http://www.waterousco.com)