

# WATEROUS

Form Number: F-3048

Issue Date: Sep 17, 2024

## AQUIS™ ULTRAFLOW 160 DLA and Non-DLA Valves Installation and Operation

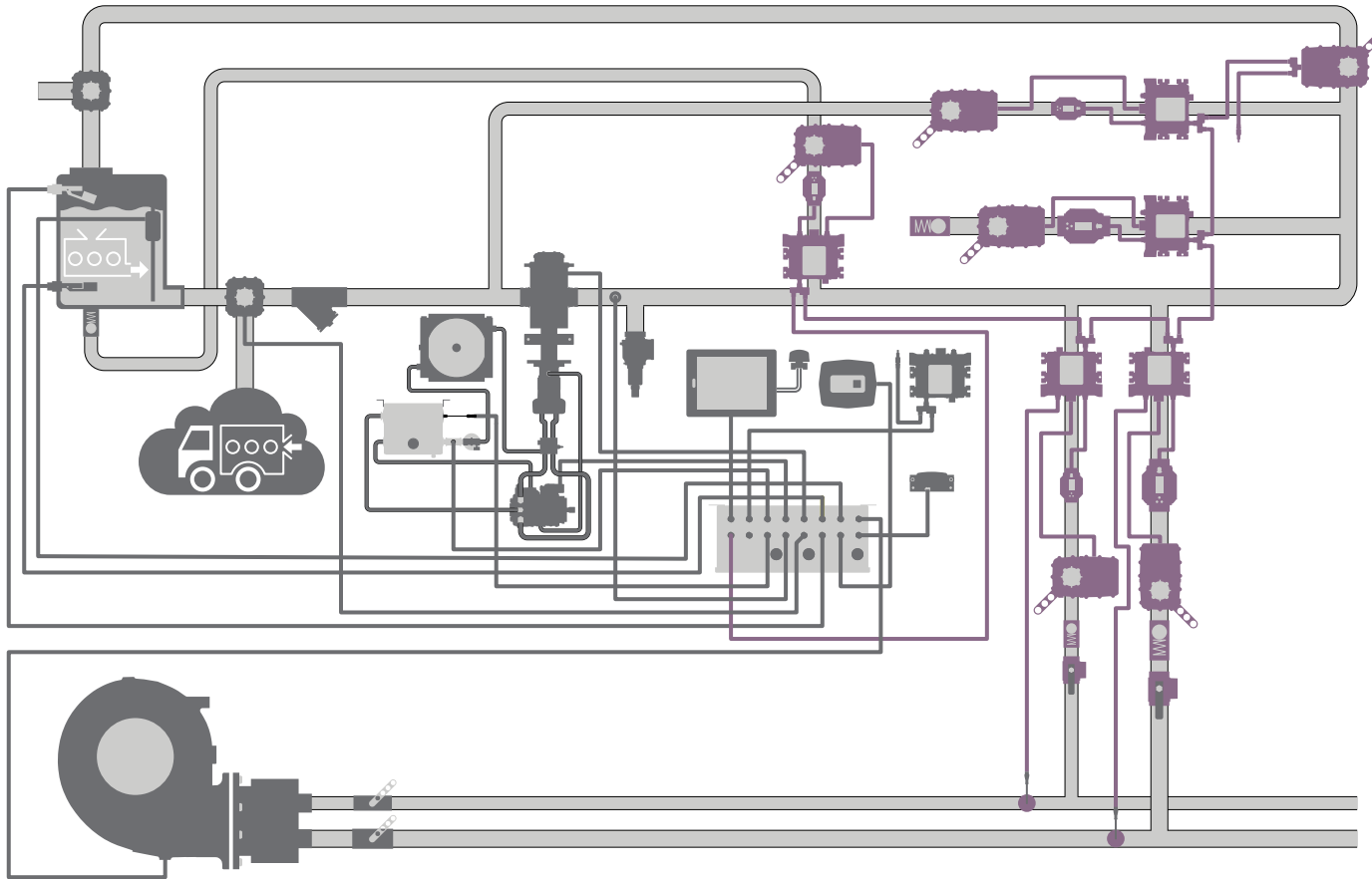

Waterous Company • 125 Hardman Avenue South • South Saint Paul, MN 55075 • (651) 450-5000

[www.waterousco.com](http://www.waterousco.com)



# Table of Contents

---

<b>Safety</b>	<b>4</b>	Connecting the Low-Flow Bypass Line	43
Safety Precautions	4	Connecting the Supply Tank Fill Line	44
<b>Introduction</b>	<b>5</b>	Connecting the Y-Splitter—Alternate Discharge Pressure	45
Using this Document	5	Installing the Transmitter and Flowmeter	46
Viewing the Document Electronically	5	Wiring the Transmitter and Flowmeter—Custom Cable Length	47
Printing the Document	5	X1 Cable Schematic—Custom Cable Length	48
Additional Documentation	5	X2 Cable Schematic—Custom Cable Length	48
<b>Overview</b>	<b>6</b>	<b>Operation</b>	<b>49</b>
Aquis UltraFlow Industrial Foam Proportioner System	6	Operation Overview	49
Discharge Line Assemblies and Valves	10	Preparing for the Operation	49
2-Inch DLA Assembly	12	During Operation	49
1-Inch DLA Assembly	14	After Operation	49
1-Inch Low-Flow Bypass Line Assembly	16	Refilling the On-Board Supply Tank—Screen View	52
Priming Valve Assembly	18	Understanding Priming	54
Paddlewheel Flowmeter	20	Understanding Over-Pressure Events	54
Pressure Transducer	22	Manually Priming the Concentrate Line	55
Terminating Resistor	23	Priming with Concentrate	55
Y-Splitter	24	Priming with Water	56
CAN Cable Splitter	25	Transferring Concentrate	57
2.0 Meter CAN Cable	26	Relaying Concentrate	58
0.5 Meter CAN Cable	27	Flushing the Apparatus Plumbing	59
3.0 Meter Sensor Cable	28	<b>Maintenance</b>	<b>60</b>
0.5 Meter Sensor Cable	29	Maintenance Schedule	60
0.5 Meter Pressure Transducer Cable—Alternate Discharge Pressure	30		
Valve Motor Cable	31		
Priming Valve Power Cable	32		
<b>Installation</b>	<b>33</b>		
Installation Overview	33		
Preparing for the Installation	33		
Modifying the Equipment	33		
Optional Equipment	33		
Determining Cable and Wire Routing	33		
Determining DLA and Valve Locations	33		
Plumbing Layout	34		
Installing the DLA Identification Labels	36		
DLA Components and Connections	38		
CAN Cables and Connections	39		
Connecting the 1-Inch DLA	40		
Connecting the 2-Inch DLA	41		
Connecting the Priming Valve	42		

## Safety Precautions

- Read and understand all the associated documentation before you begin operating or overhauling the equipment.
- Contact Waterous when you have questions about operating, maintaining, or overhauling the equipment.
- Read and understand all the notices and safety precautions.
- Do not operate the equipment when safety guards are removed.
- Do not modify the equipment.

 <b>WARNING</b>	
<p><b>High Pressure</b></p> <ul style="list-style-type: none"> <li>• Discharge ejected at high pressure can cause serious injury and damage.</li> <li>• Direct discharge away from people and equipment.</li> </ul>	

<b>NOTICE</b>	
<p><b>Modification</b></p> <ul style="list-style-type: none"> <li>• Modifying the equipment can damage components and void your warranty.</li> <li>• Do not modify the system or any of its components.</li> </ul>	

<b>NOTICE</b>	
<p><b>Before Operation</b></p> <ul style="list-style-type: none"> <li>• Read and understand all the instructions provided.</li> <li>• Check all fluid levels and replenish if necessary.</li> <li>• Remove all shipping plugs and install the operation plugs or caps.</li> </ul>	

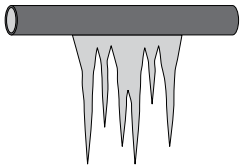
<b>NOTICE</b>	
<p><b>Freeze Damage</b></p> <ul style="list-style-type: none"> <li>• Do not allow fluid in the lines to freeze.</li> <li>• Remove all freezable fluid from the lines before storing the apparatus.</li> </ul>	

<b>NOTICE</b>	
<p><b>Concentrate Supply Contamination</b></p> <ul style="list-style-type: none"> <li>• Priming with water can contaminate the on-board concentrate supply.</li> <li>• Divert water to prevent concentrate contamination.</li> </ul>	

 Read and understand all notices following this symbol.

Use this document to install and operate your Waterous equipment. Understand the following conditions before continuing with the document:

- The instructions may refer to options or equipment that you may not have purchased with your system.
- The illustrations in this document are intended to convey concepts. Do not use the illustrations to determine physical attributes, placement, or proportion.
- Understand that your application may require additional steps, that are not described in the illustrations or instructions, to perform the installation.
- The equipment described in this document is intended to be installed by a person or persons with the necessary skills and knowledge to perform the installation.
- The equipment described in this document is intended to be operated by a person or persons with the basic knowledge of operating similar equipment.
- The information in this document is subject to change without notice.

This document is divided into the following sections:

#### SAFETY

This section describes general precautions and alert symbols in the document.

#### INTRODUCTION

This section is an overview of the document.

#### OVERVIEW

This section describes the components that make up the system.

#### INSTALLATION

This section describes the installation and initial setup procedures.

#### OPERATION

This section describes the equipment operation.

#### MAINTENANCE

This section describes any required maintenance.

## Using this Document

---

Use the guidelines below when viewing this document.

### Viewing the Document Electronically

---

- View this document in landscape orientation.
- Use the table of contents to navigate directly to that section.
- Text **with this appearance** is linked to a reference.

### Printing the Document

---

- This document is designed to be printed on both sides and in color.
- Use a 3-ring binder to store the document.

## Additional Documentation

---

Additional documentation is available through the MyWaterous login at [waterousco.com](http://waterousco.com). Use your serial number to gain access to the service parts list associated with your system. Dimensional drawings are available through the Waterous Service department.

## Aquis UltraFlow Industrial Foam Proportioner System

*Note: Make sure that the installer-supplied UltraFlow plumbing cannot trap fluid and allows fluid to be drained from the system when required.*

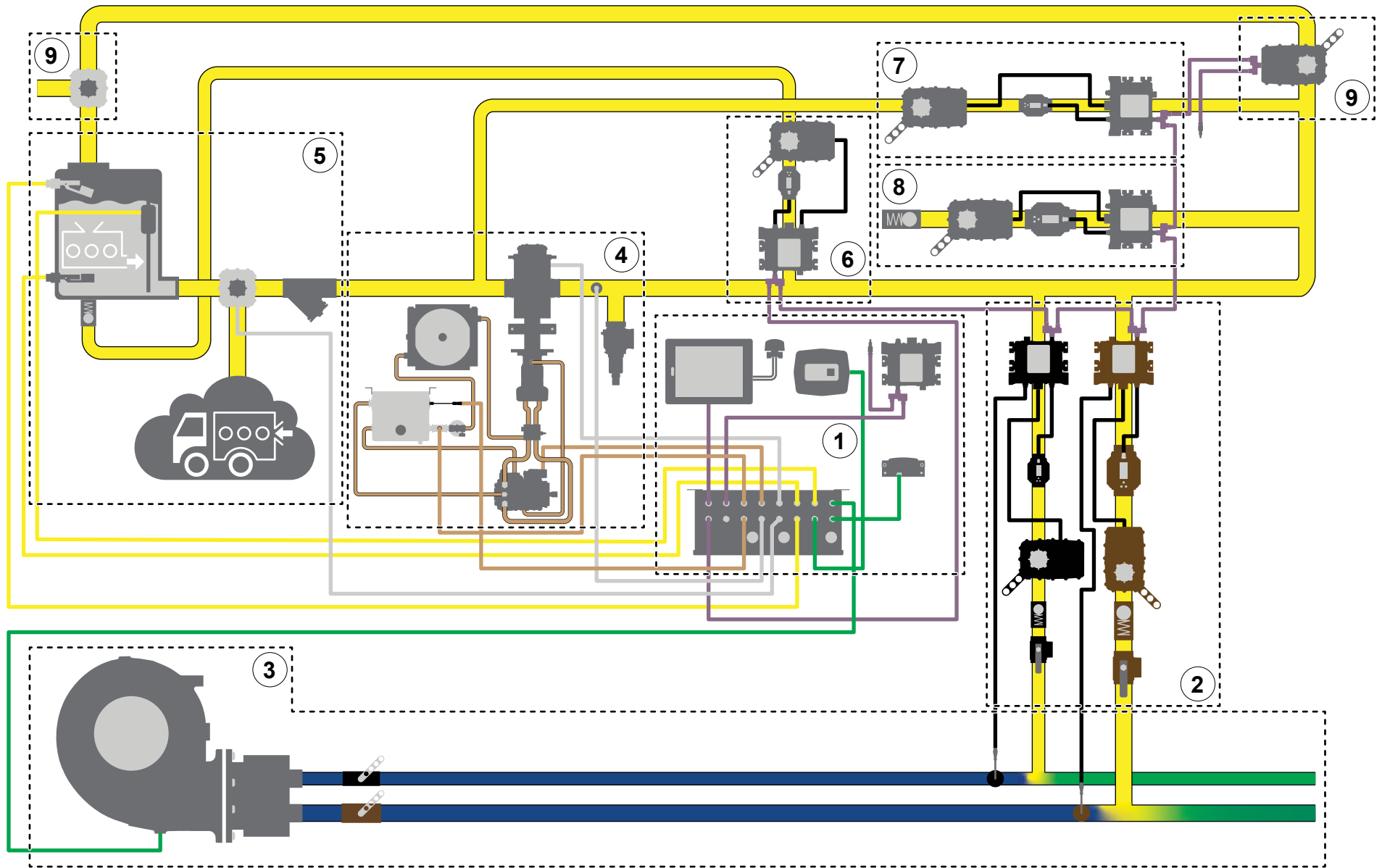

## Aquis UltraFlow Industrial Foam Proportioner System

The Aquis UltraFlow industrial foam proportioner system supplies concentrate into a solution-capable discharge line. A Tellurus™ control panel, or human machine interface (HMI), shows system activity and provides control of the system using a CANbus protocol. Foam concentrate is sourced from an on-board supply tank or an auxiliary source. The concentrate pump distributes concentrate through the discharge line assembly (DLA) using hydraulic components. The concentrate is then measured, controlled, and introduced into the solution-capable discharge line to produce foam solution. Understand that your application will include all or portions of the components described.

Subsystem	Description
1 Control system	<p>This monitors and controls the foam proportioner system. The components in this subsystem include:</p> <ul style="list-style-type: none"> <li>• Control panel—this displays system operation and provides control of the system.</li> <li>• Control box—this connects to various system components and contains the programmable logic controllers (PLCs).</li> <li>• Manual override panel—this disables the automatic control of the concentrate control valves.</li> <li>• Power relay panel—this enables and disables power to the DLA.</li> <li>• Remote I/O—this adds a node controller to the system for additional options required in your application.</li> <li>• Various cables—these provide communication and power to system components.</li> </ul>
2 Discharge line assembly	<p>This manages the concentrate injected into the solution-capable discharge. The system can control up to 19 DLAs. The components in this subsystem include:</p> <ul style="list-style-type: none"> <li>• Node controller—this connects to and controls the concentrate control valve, and reads the flowmeters and discharge pressure transducer.</li> <li>• CAN cable splitter—this connects the node controllers to one another and the control box.</li> <li>• DLA terminating resistor—this terminates the CAN connection on the last node controller or valve in the CAN chain.</li> <li>• Concentrate control valve—this controls the concentrate flow.</li> <li>• Magnetic flowmeter—this measures the concentrate flow.</li> <li>• Check valve—this prevents contamination of concentrate by preventing reverse fluid flow in the line.</li> <li>• Cal/Inject valve—this allows you to divert and collect water or concentrate when calibrating the your system.</li> </ul>
3 Solution-capable discharge	<p>This includes the installer-supplied water pump, distribution manifold, plumbing, and additional components that produce water flow. Additional components in this subsystem include:</p> <ul style="list-style-type: none"> <li>• Paddlewheel flowmeter—this measures the water flow in the discharge.</li> </ul> <p><b>Note:</b> You can install the flowmeter upstream or downstream of where the concentrate is injected into the waterway.</p> <ul style="list-style-type: none"> <li>• Water discharge pressure transducer—this measures the pressure at the pump discharge.</li> </ul> <p><b>Note:</b> Some applications do not allow for the discharge pressure to be measured at the pump, in those applications alternative measurement methods are used.</p> <ul style="list-style-type: none"> <li>• Solution discharge pressure transducer—this measures the pressure at the solution-capable discharge.</li> </ul>

## Aquis UltraFlow Industrial Foam Proportioner System

Subsystem	Description
4 Concentrate pump	<p>These components support, control, and power the concentrate pump. The components in this subsystem include:</p> <ul style="list-style-type: none"> <li>• Concentrate pump—this circulates the foam concentrate through the system.</li> <li>• Hydraulic motor—this drives the concentrate pump.</li> <li>• Hydraulic pump—this drives the hydraulic motor.</li> <li>• Hydraulic reservoir—this contains the hydraulic fluid supply.</li> <li>• Hydraulic filter—this filters the hydraulic fluid.</li> <li>• Hydraulic heat exchanger—this cools the hydraulic fluid.</li> <li>• Hydraulic temperature sensor—this measures the hydraulic fluid temperature.</li> <li>• Hydraulic temperature switch—this activates the fan control circuit.</li> <li>• Hydraulic level sensor—this monitors the hydraulic fluid level in the reservoir.</li> <li>• Loop flush manifold—this draws hot hydraulic fluid from the main hydraulic lines and sends it to the heat exchanger.</li> <li>• Concentrate discharge pressure transducer—this measures the pressure in the concentrate line.</li> <li>• Pressure relief valve—this limits the pressure in the concentrate discharge manifold by opening when the pressure reaches a predetermined level.</li> </ul>
5 Concentrate supply	<p>This contains components that hold or supply foam concentrate for the system. The components in this subsystem include:</p> <ul style="list-style-type: none"> <li>• Concentrate supply tank—this contains the on-board foam concentrate supply.</li> <li>• Tank-full sensor—this indicates a tank full condition to the system.</li> <li>• Tank-low sensor—this indicates a tank low condition to the system.</li> <li>• Tank level sensor—this is an installer-supplied sensor and display that indicates the supply level in the tank.</li> <li>• Concentrate pump intake select valve—this is an installer-supplied, 2-position valve and additional components that source concentrate from an on-board tank or an auxiliary supply. A signal is provided to the system to ignore the on-board tank sensors when sourcing concentrate from an auxiliary supply.</li> <li>• Concentrate strainer—this collects debris that would otherwise flow through the system and potentially damage the concentrate pump.</li> </ul>
6 Concentrate supply refill line	<p>This allows you to fill the on-board tank from an external source. The components in this subsystem include:</p> <ul style="list-style-type: none"> <li>• Node controller—this connects to the fill valve and flowmeters.</li> <li>• Fill line control valve—this controls the concentrate flow.</li> <li>• Magnetic flowmeter—this measures the concentrate flow.</li> <li>• CAN cable splitter—this connects the node controllers to one another and the control box.</li> <li>• Check valve—this prevents reverse fluid flow in the line.</li> </ul>



## Aquis UltraFlow Industrial Foam Proportioner System

Subsystem	Description
7 Low-flow bypass line	<p>This returns a portion of the concentrate in the supply line back to the pump inlet when the desired concentrate output requires the pump to operate at an rpm that is lower than its capabilities. The components in this subsystem include:</p> <ul style="list-style-type: none"> <li>• Node controller—this connects to the low-flow control valve and flowmeters.</li> <li>• Low-flow valve—this controls the concentrate return flow.</li> <li>• Magnetic flowmeter—this measures the concentrate flow.</li> <li>• CAN cable splitter—this connects the node controllers to one another.</li> </ul>
8 Transfer line	<p>This allows you to transfer or relay concentrate from the apparatus to another location. The components in this subsystem include:</p> <ul style="list-style-type: none"> <li>• Node controller—this connects to and controls the concentrate control valve and flowmeters.</li> <li>• CAN cable splitter—this connects the node controllers to one another and the control box.</li> <li>• Concentrate control valve—this controls the concentrate flow.</li> <li>• Magnetic flowmeter—this measures the concentrate flow.</li> <li>• Check valve—this prevents reverse fluid flow in the line.</li> </ul>
9 Priming line	<p>This evacuates air from the concentrate pump inlet as the system primes before operation. The components in this subsystem include:</p> <ul style="list-style-type: none"> <li>• Priming valve—this opens to allow air to evacuate the line before operation.</li> <li>• CAN cable splitter—this connects the node controllers to one another and the control box.</li> <li>• Prime bypass valve—this is an installer-supplied valve that prevents contaminating the concentrate during training. When water is substituted for concentrate during training or testing, and there is concentrate in the supply tank, this bypass valve prevents water from contaminating the concentrate supply.</li> </ul> <p><b>Note:</b> You must drain any remaining water in the line before priming the system with concentrate to prevent contamination.</p>

## Discharge Line Assemblies and Valves

A comprehensive application of the UltraFlow system includes multiple DLAs. They serve different functions and can be integrated into your application in a variety of ways.

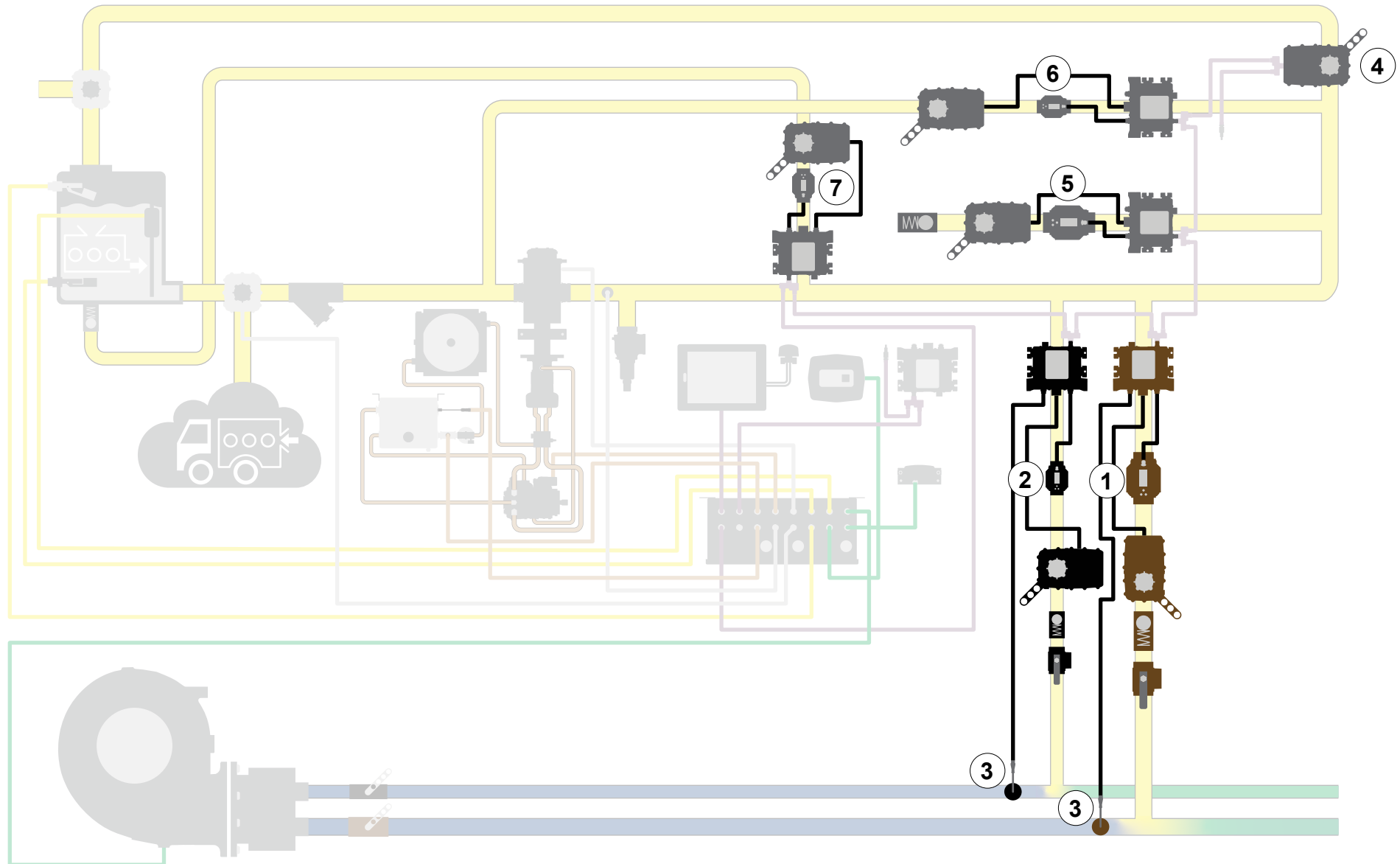

## Discharge Line Assemblies and Valves

Subsystem	Description
1 2-inch magnetic flowmeter DLA	This manages the concentrate injected into the solution-capable discharge—237 gpm maximum flow rate.
2 1-inch magnetic flowmeter DLA	This manages the concentrate injected into the solution-capable discharge—26 gpm maximum flow rate.
3 Paddlewheel flowmeter	The paddlewheel flowmeter measures the flow in the solution-capable discharge.
4 Priming valve	This evacuates air from the concentrate pump inlet as the system primes before operation.
5 Transfer or relay DLA	This allows you to transfer or relay concentrate from the apparatus to another location.
6 Low-flow bypass line assembly	This returns a portion of the pumped concentrate in the supply line back to the pump inlet when the desired concentrate output requires the pump to operate at an rpm that is lower than its capabilities. It is available in a 1-inch or 2-inch configuration. Choose the 1-inch low-flow bypass line assembly for concentrate pumps rated at less than 300 gpm and the 2-inch low-flow bypass line assembly for concentrate pumps rated at more than 300 gpm.
7 Supply tank fill line	This allows you to fill the on-board tank from an auxiliary source.

## 2-Inch DLA Assembly

The DLA manages the concentrate injected into a solution-capable discharge. This is also used as a 2-inch low-flow bypass, 2-inch transfer/relay, and a 2-inch concentrate supply refill line.

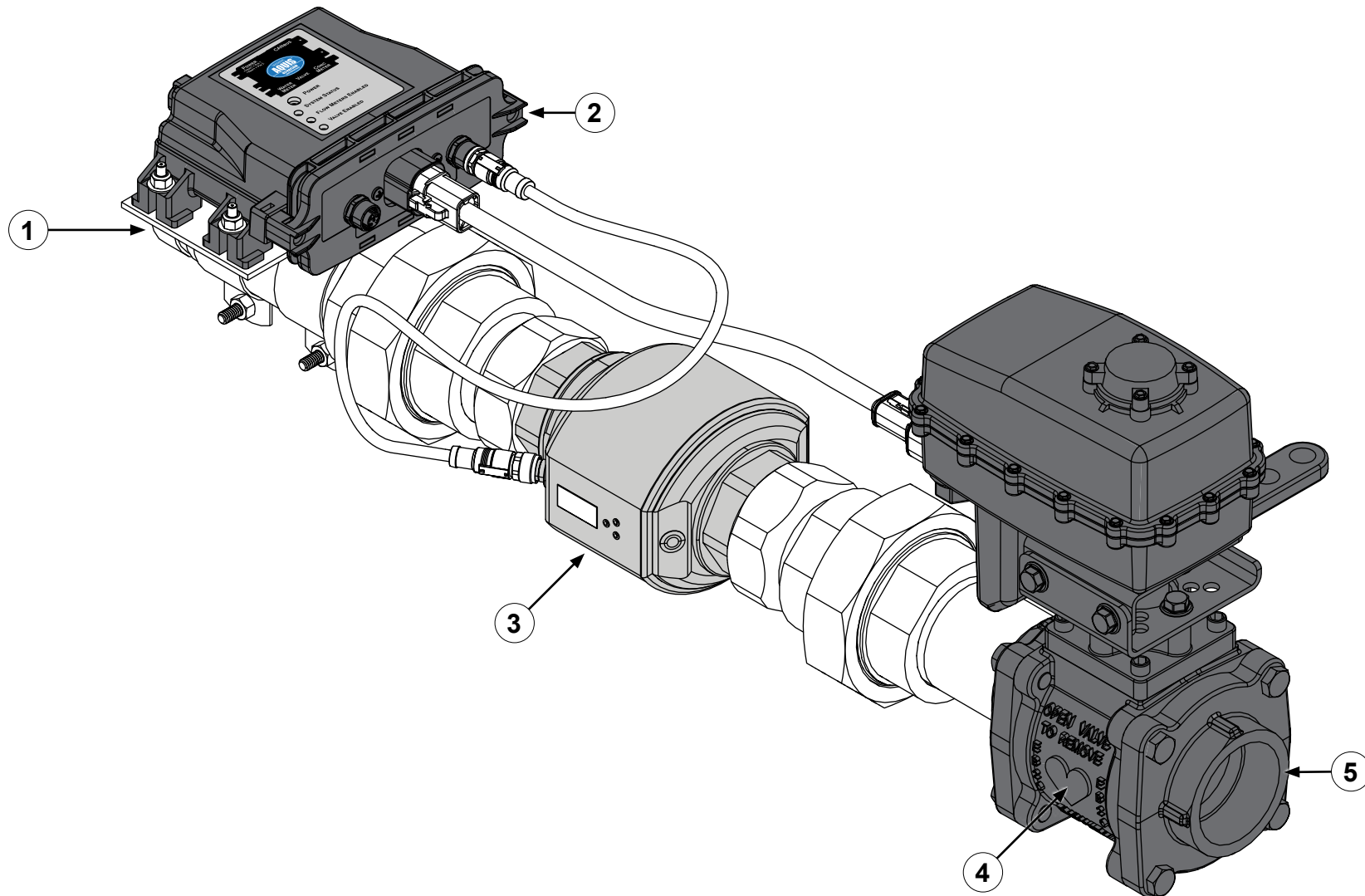

## 2-Inch DLA Assembly

---

Feature	Description
1 Concentrate inlet	This is where the concentrate enters the valve assembly—2-inch Victaulic.
2 Node controller	This monitors and controls the valve assembly.
3 Magnetic flowmeter—2-inch	This measures the concentrate flow—237 gpm maximum flow rate.
4 Electric valve	This controls the concentrate flow into the discharge line.
5 Concentrate outlet	This is where the concentrate exits the valve assembly—2 NPT.

# 1-Inch DLA Assembly

The DLA manages the concentrate injected the solution-capable discharge.

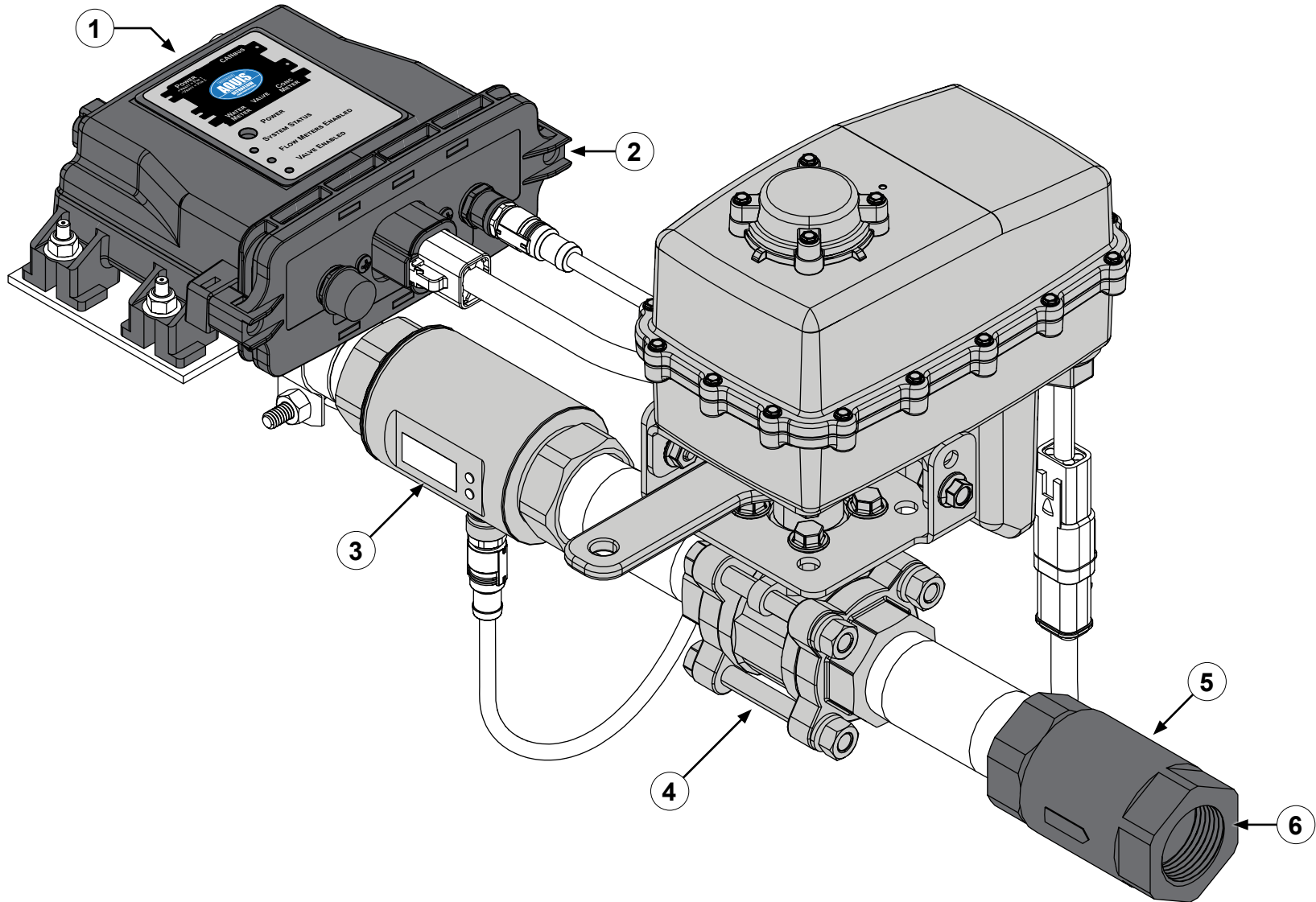

## 1-Inch DLA Assembly

---

Feature	Description
1 Concentrate inlet	This is where the concentrate enters the valve assembly—1-inch Victaulic.
2 Node controller	This monitors and controls the valve assembly.
3 Magnetic flowmeter—1-inch	This measures the concentrate flow—26 gpm maximum flow rate.
4 Electric valve	This controls the concentrate flow into the discharge line.
5 Check valve	This prevents reverse fluid flow in the line.
6 Concentrate outlet	This is where the concentrate exits the valve assembly—1 NPT.

## 1-Inch Low-Flow Bypass Line Assembly

This returns a portion of the pumped concentrate in the supply line back to the pump inlet when the desired concentrate output requires the pump to operate at an rpm that is lower than its capabilities.

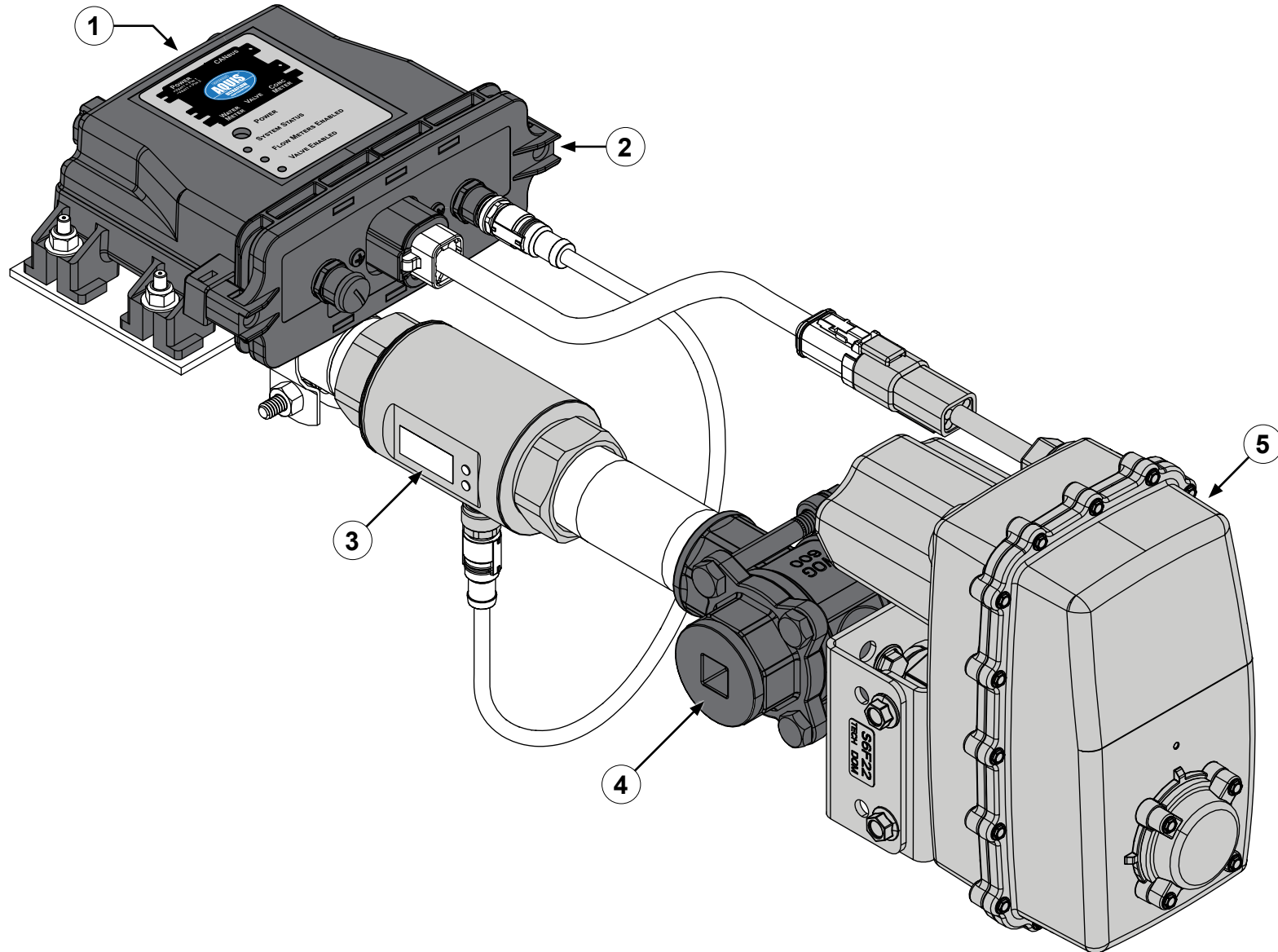



## 1-Inch Low-Flow Bypass Line Assembly

---

Feature	Description
1 Concentrate inlet	This is where the concentrate enters the valve assembly—1-inch Victaulic.
2 Node controller	This monitors and controls the valve assembly.
3 Magnetic flowmeter—1-inch	This measures the concentrate flow—26 gpm maximum flow rate.
4 Valve	This opens and closes during low-flow operation—1 NPT.
5 Electric valve	This controls the concentrate flow into the low-flow bypass line.

## Priming Valve Assembly

This evacuates air from the concentrate line as the system primes before operation.

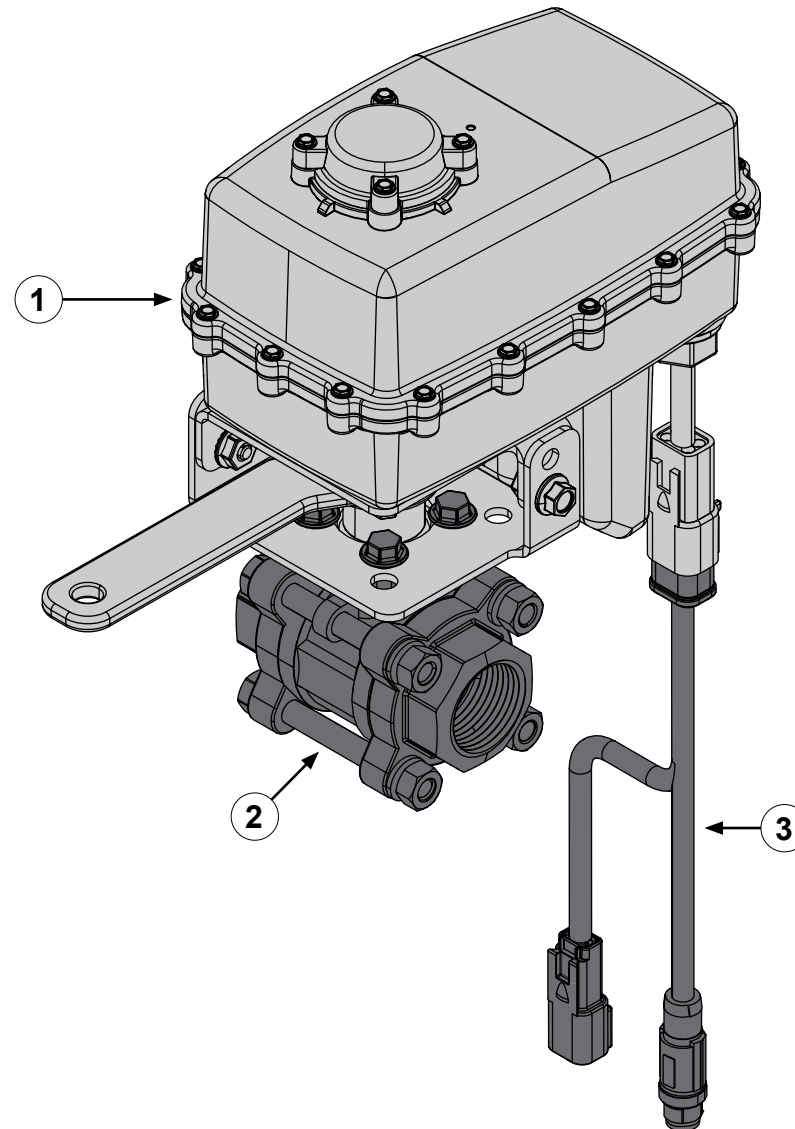

## Priming Valve Assembly

---

Feature	Description
1 Electric valve	This controls the concentrate valve.
2 Valve	This opens and closes during priming—1 NPT.
3 Cable	This connects to apparatus power and the CAN system.

## Paddlewheel Flowmeter

The paddlewheel flowmeter measures the flow in the solution-capable discharge.

**Note:** Accurate measurement is dependent on proper installation in the waterway. Refer to the manufacturer's instructions for the paddlewheel to properly install the flowmeter into your application.

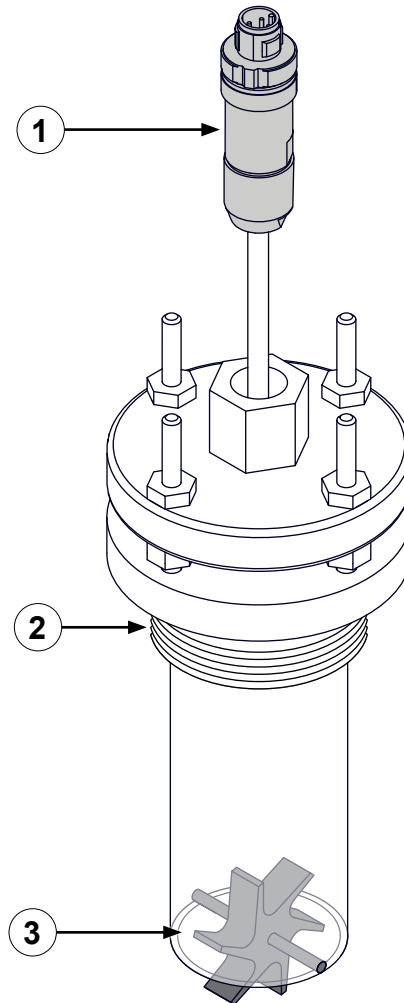

## Paddlewheel Flowmeter

---

Feature	Description
1 Connector	This connects to the associated DLA node controller.
2 Body	This installs into the discharge line—2 NPT.
3 Paddlewheel	This measures the water flow in the solution-capable discharge.

## Pressure Transducer

The pressure transducer measures the pressure of different lines in the system.

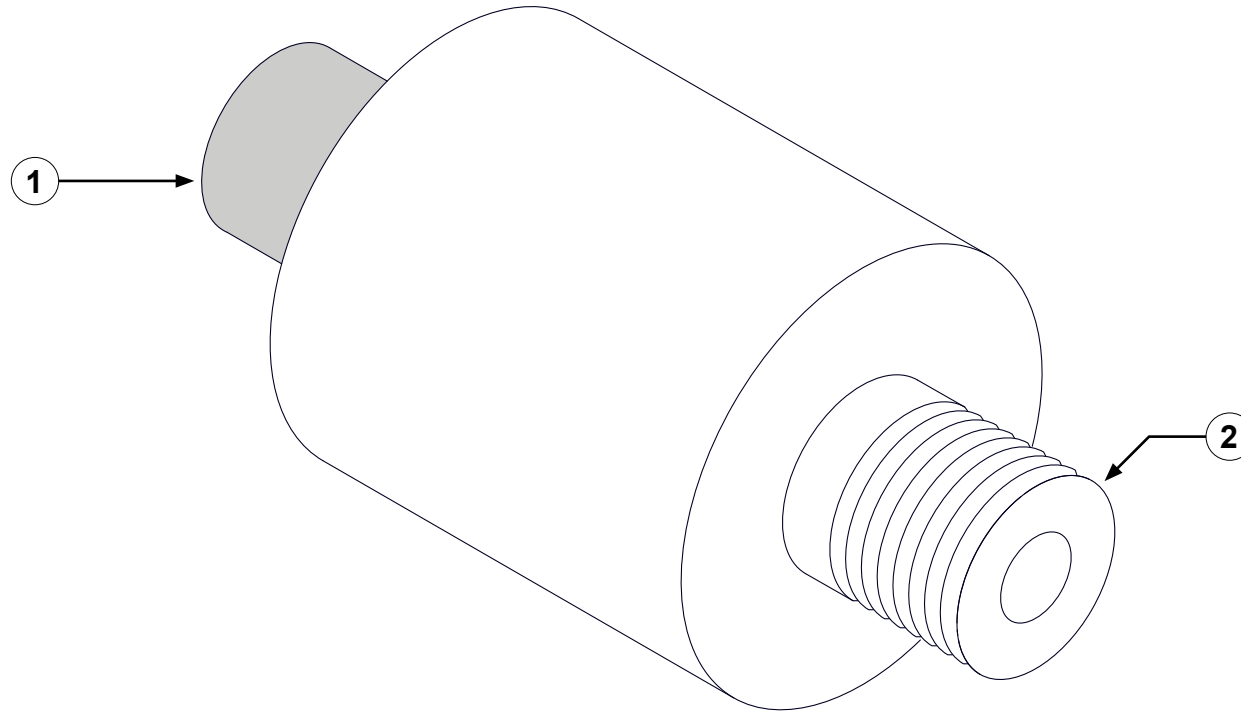

Feature	Description
1 M12 connector	This connects to the control box through a sensor cable or to the node controller Y-splitter when the water discharge pressure is unable to be measured at the pump.
2 Pressure sensor	This measures the pressure at the discharge of the water pump—1/4 NPT, 0–500 psi.

## Terminating Resistor

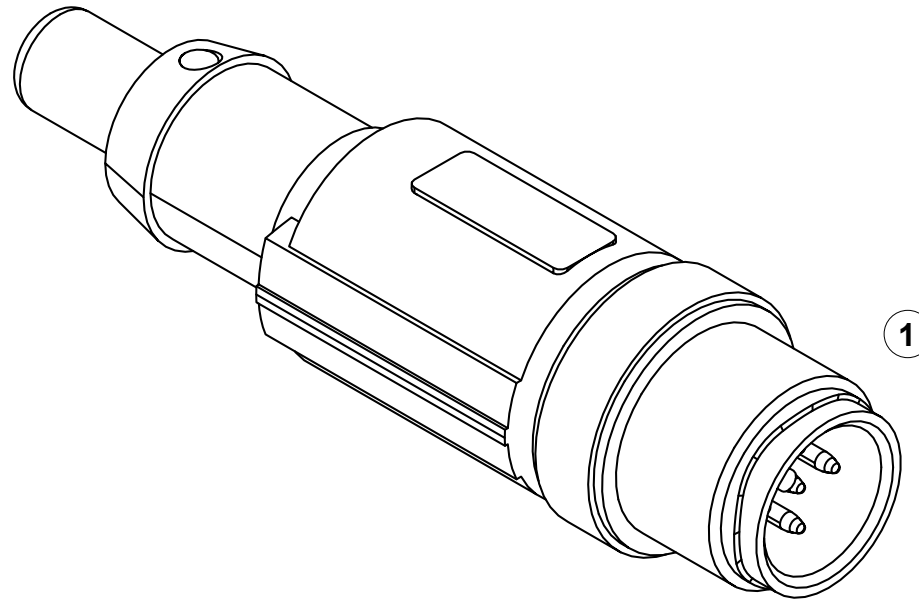

Feature	Description
1 Terminating resistor	This connects to the node connector on the CAN cable splitter on the last DLA in the system.

## Y-Splitter

This splits the M12 connection to allow flowmeter communication on pin 4 and pressure sensor communication on pin 2 when the water pump discharge pressure is not supplied to the system.

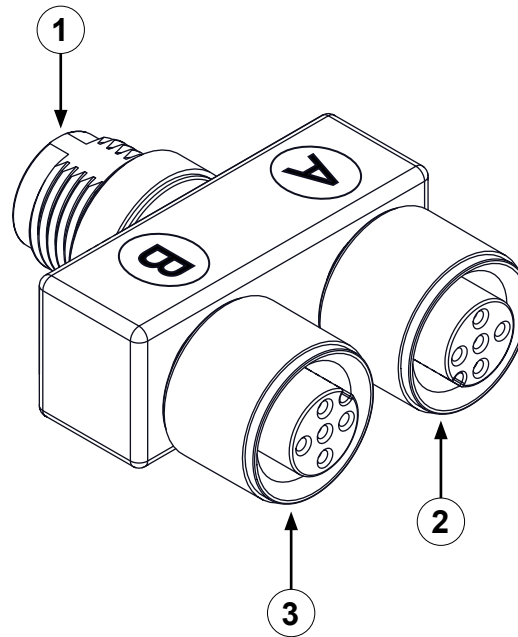

Feature	Description
1 Node connector	This connects to the node controller.
2 A-connector	This connects to the paddlewheel flowmeter.
3 B-connector	This connects to the pressure sensor.



## CAN Cable Splitter

The CAN cable splitter communicates data between the CAN connections. It is typically violet.

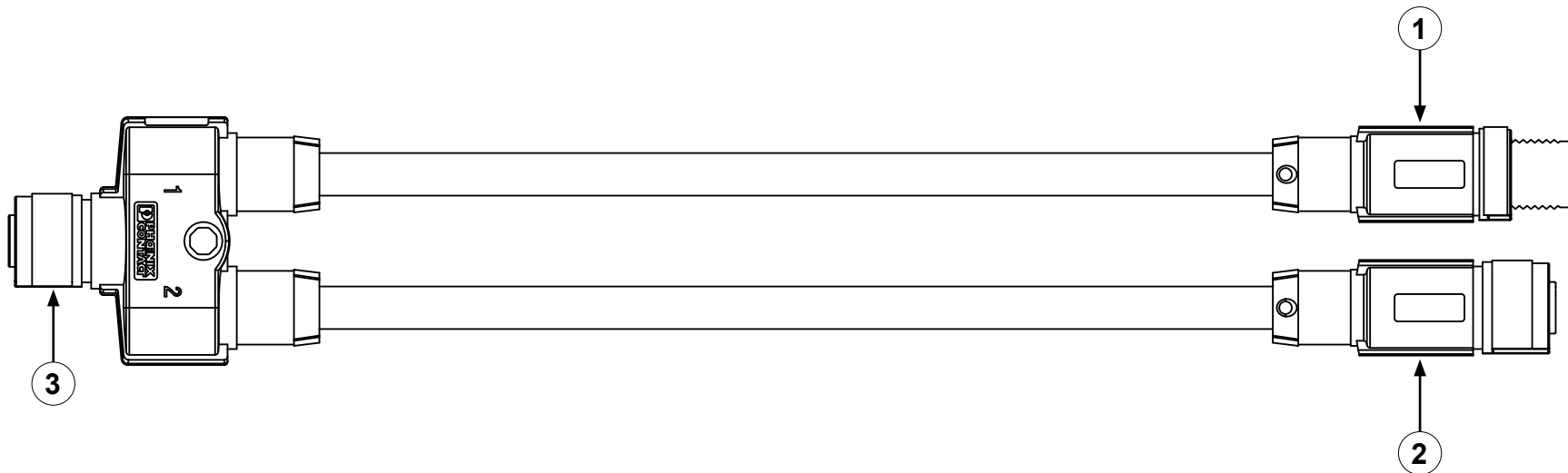

Feature	Description
1 CAN output—male	This connects to the next node in the chain or the terminating resistor.
2 CAN input—female	This connects to the previous node in the chain or the discharge CANbus connector on the control box.
3 Node connector—female	This connects to the node controller.

## 2.0 Meter CAN Cable

The CAN cable communicates data between the CAN connections. It is typically violet. The CAN cable is not interchangeable with the sensor cable. You can connect 2 or more cables together to achieve a desired length.

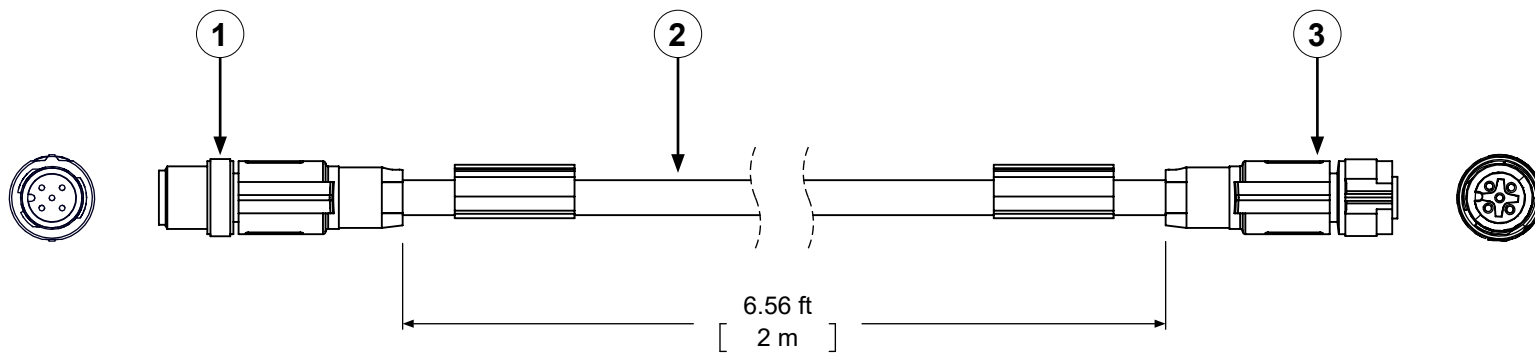

Feature	Description
1 M12 connector	This is a male connector.
2 Cable	This is typically a violet cable jacket.
3 M12 connector	This is a female connector.

## 0.5 Meter CAN Cable

The CAN cable communicates data between the CAN connections. It is typically violet. The CAN cable is not interchangeable with the sensor cable. You can connect 2 or more cables together to achieve a desired length.

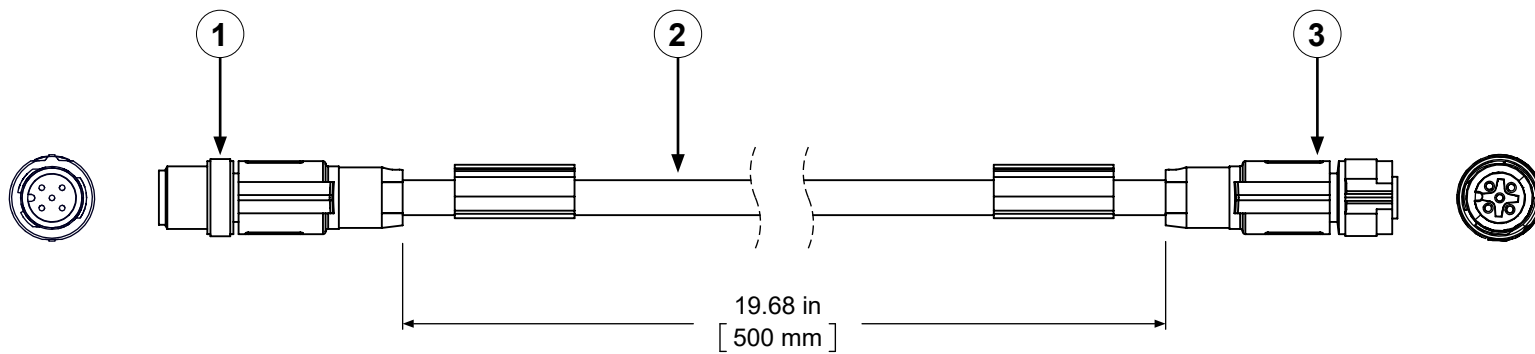

Feature	Description
1 M12 connector	This is a male connector.
2 Cable	This is typically a violet cable jacket.
3 M12 connector	This is a female connector.

### 3.0 Meter Sensor Cable

The sensor cable communicates data between the various connections. It is typically yellow, gray, or black. The sensor cable is not interchangeable with the CAN cable. You can connect 2 or more cables together to achieve a desired length.

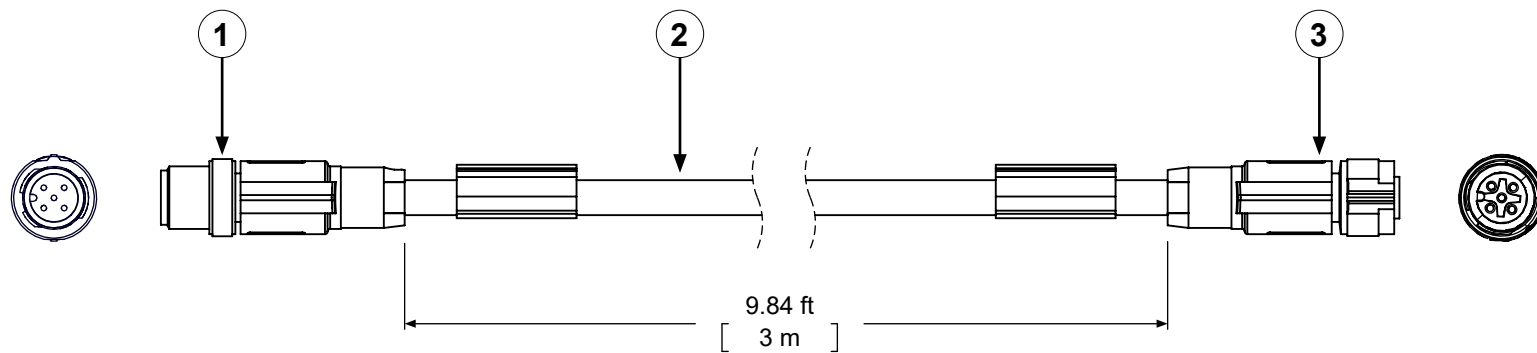

Feature	Description
1 M12 connector	This is a male connector.
2 Cable	This is typically a yellow, gray, or black cable jacket.
3 M12 connector	This is a female connector.

## 0.5 Meter Sensor Cable

The sensor cable communicates data between the various connections. It is typically yellow, gray, or black. The sensor cable is not interchangeable with the CAN cable. You can connect 2 or more cables together to achieve a desired length.

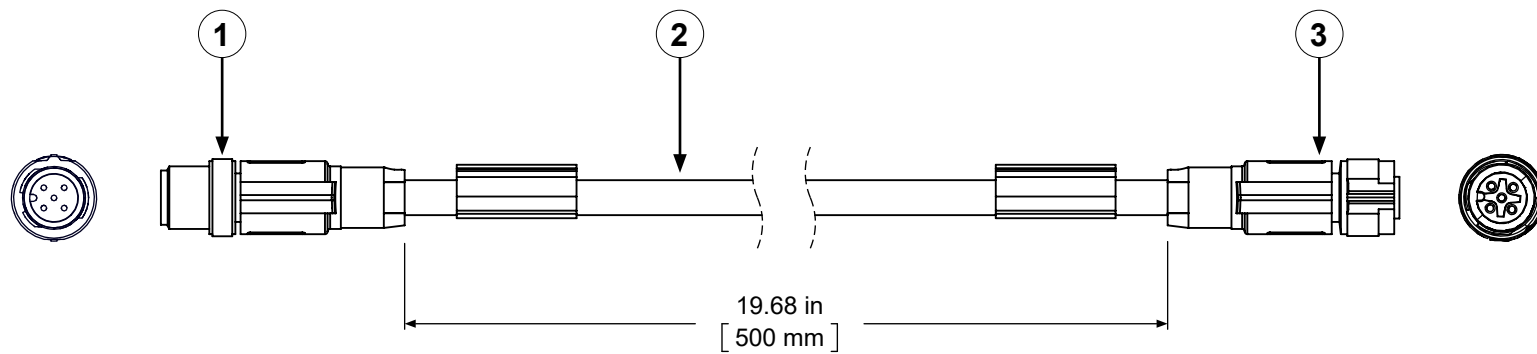

Feature	Description
1 M12 connector	This is a male connector.
2 Cable	This is typically a yellow, gray, or black cable jacket.
3 M12 connector	This is a female connector.

## 0.5 Meter Pressure Transducer Cable—Alternate Discharge Pressure

This cable is used with the Y-splitter when you require an alternate discharge pressure measurement. It is typically a gray cable with yellow connectors. The pressure transducer cable is not interchangeable with the CAN or sensor cables.

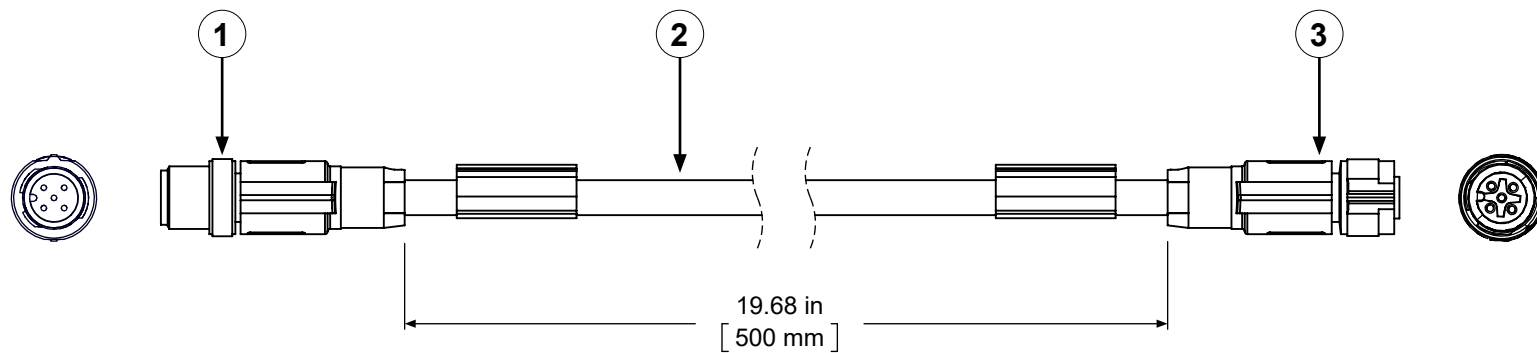

Feature	Description
1 M12 connector	This is a male connector.
2 Cable	This is typically a gray cable jacket.
3 M12 connector	This is a female connector.

## Valve Motor Cable

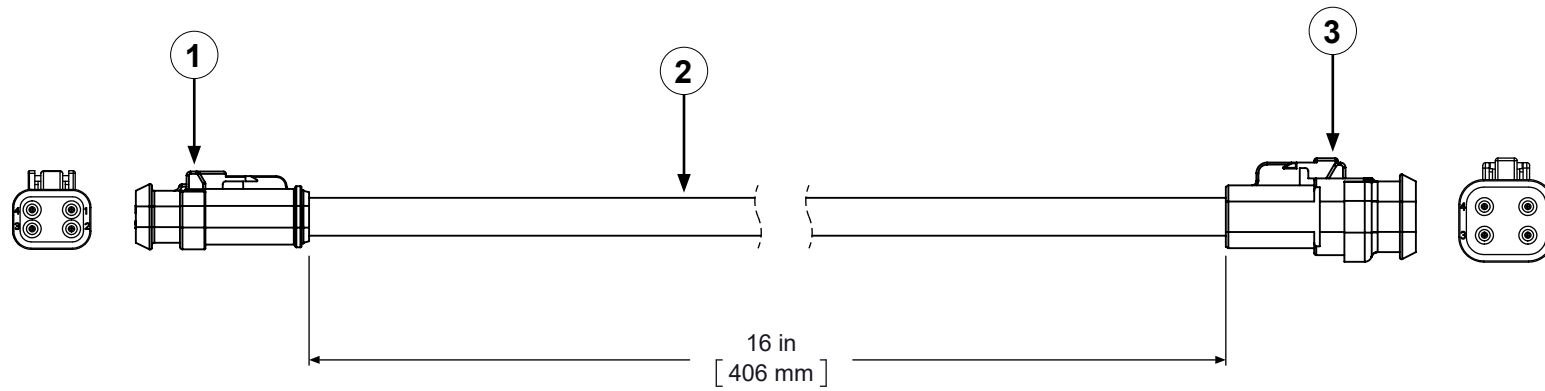

Feature	Description
1 Connector	This connects to the DLA control valve.
2 Cable	This is a braided loom jacket.
3 Connector	This connects to the DLA node controller.

## Priming Valve Power Cable

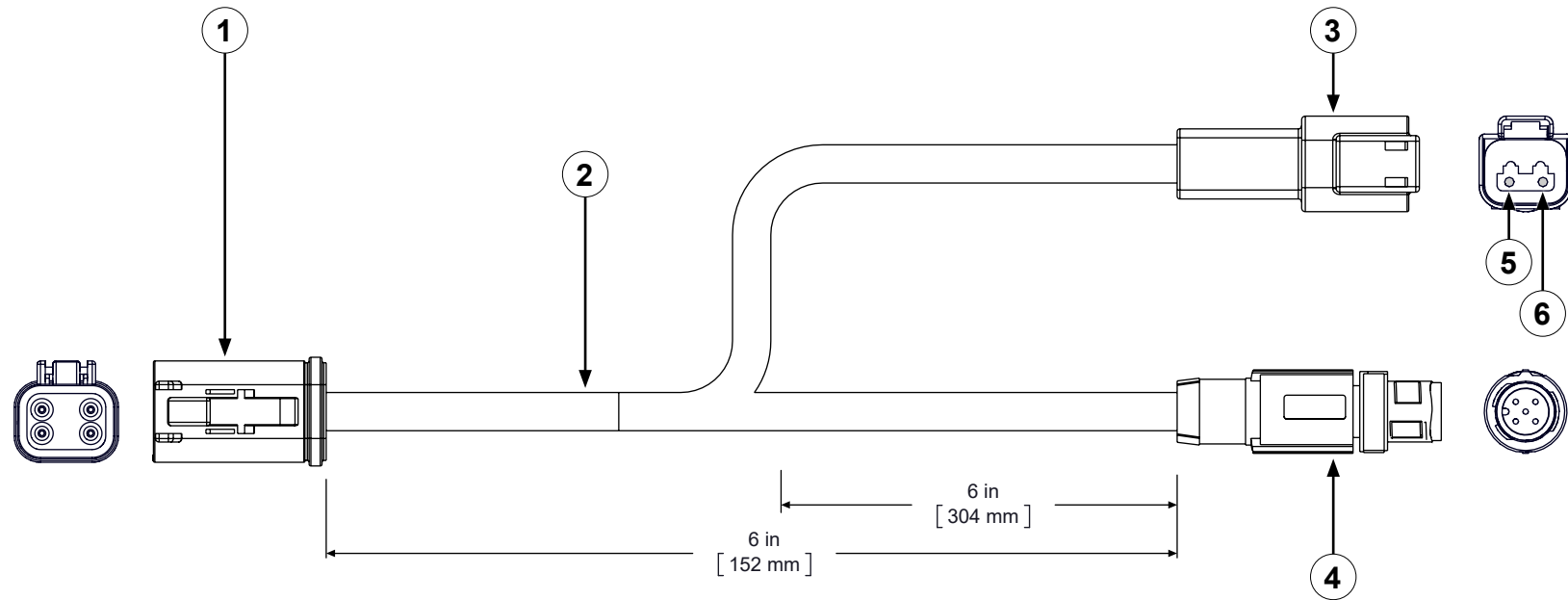

Feature	Description
1 Connector	This connects to the priming valve.
2 Cable	This is a braided loom cable jacket.
3 Connector	This connects to apparatus power.
4 M12 connector	This connects to the discharge CANbus connector on the control box.
5 Pin 1	Power +12V, red
6 Pin 2	Ground, black



## Installation Overview

This equipment is intended to be installed by a person or persons with the basic knowledge of installing similar equipment. Contact Waterous with questions about installing the equipment. The installation may require the following tasks and abilities:

- Locating, drilling, and cutting features into the apparatus.
- Welding.
- Installing the hoses and fittings.
- Routing and securing the hoses.
- Routing and securing the wiring.
- Calibrating the output.
- Calibration and final testing.

## Preparing for the Installation

Use the following guidelines before, during, and after the installation.

- Read and understand all the installation instructions before installing the equipment.
- Prepare a suitable, well-lit area and gather all the necessary tools before you begin the installation.
- Make sure that you remove any shipping plugs or caps before installing the component.
- Make sure that you bring all fluids to operating levels before using the equipment.

## NOTICE

### Before Operation

- **Read and understand all the instructions provided.**
- **Check all fluid levels and replenish if necessary.**
- **Remove all shipping plugs and install the operation plugs or caps.**



## Modifying the Equipment

This equipment is intended to operate as designed. Do not remove, modify, or change the components in the system. Doing so will void the warranty. Contact Waterous for more information.

## NOTICE

### Modification

- **Modifying the equipment can damage components and void your warranty.**
- **Do not modify the system or any of its components.**

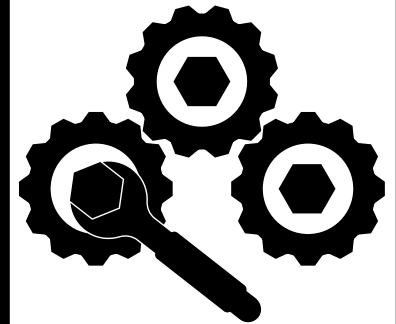

*Do not modify the system or any components. Doing so will void your warranty.*

## Optional Equipment

Be aware that the installation instruction may include optional equipment not included in your application.

## Determining Cable and Wire Routing

Use the *Wiring Best Practices* document, available at [www.waterousco.com](http://www.waterousco.com), as a guide to select and route wiring for your application.

## Determining DLA and Valve Locations

Use the following guidelines to determine DLA and valve locations:

- Consider the cable routing and plumbing.
- Consider accessibility during operation and maintenance.

## Plumbing Layout

Use the illustration as a guide to lay out the plumbing connections for your application.

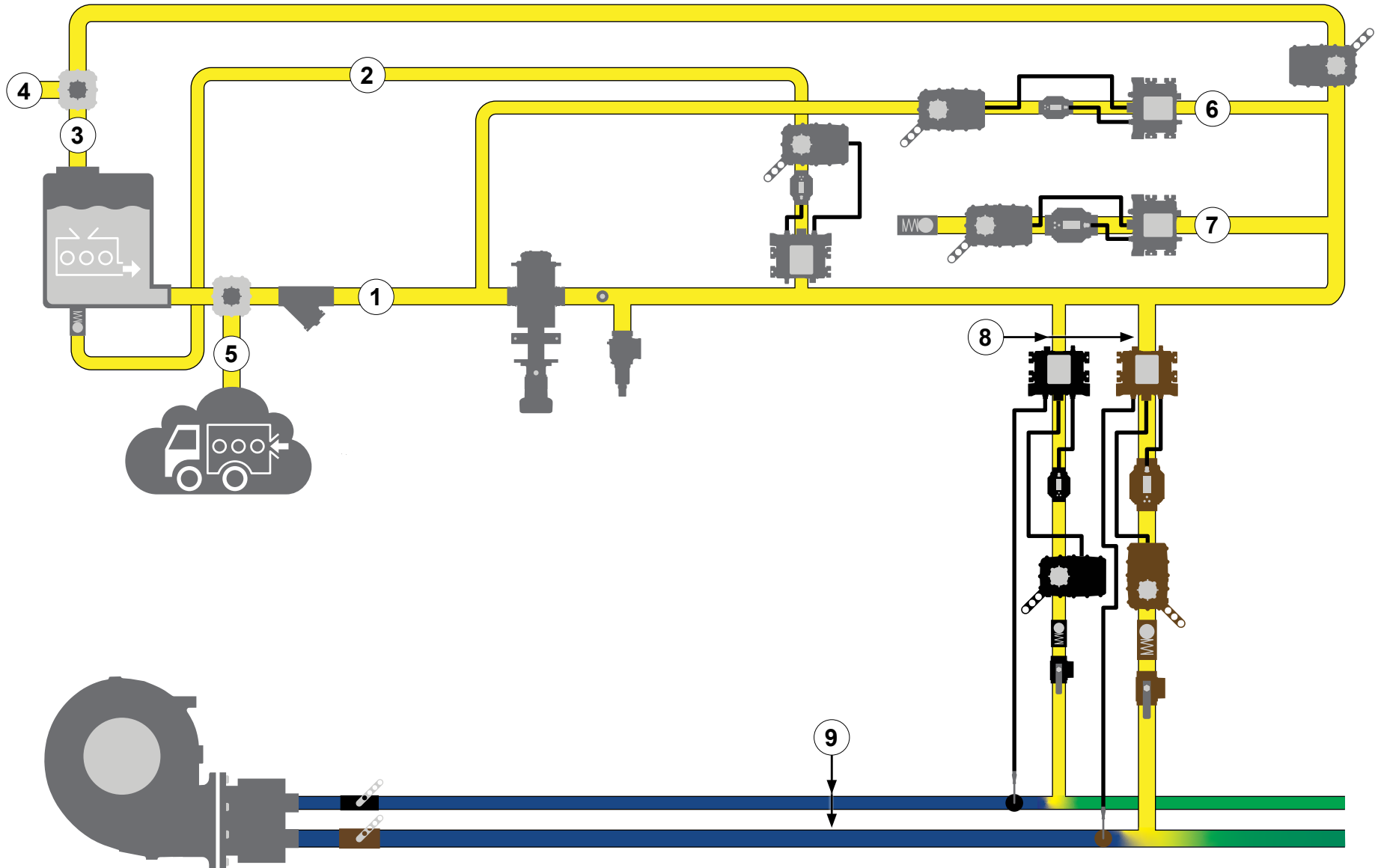

## Plumbing Layout

Feature	Description
1 Concentrate supply line	This transports concentrate around the system.
2 Concentrate supply refill line	This allows you to fill the on-board tank from an auxiliary source.
3 Priming line	This evacuates air from the concentrate pump inlet as the system primes before operation.
4 Priming bypass line	This prevents contamination to the concentrate during testing and training. When water is substituted for concentrate during training or testing and there is concentrate in the supply tank, this bypass valve diverts water from the supply tank to prevent concentrate contamination. It is also important to make sure that you drain any remaining water in the line before priming the system with concentrate.
5 Auxiliary concentrate supply line	This allows you to source concentrate from an external source.
6 Low-flow bypass line	This returns a portion of the pumped concentrate in the supply line back to the pump inlet when the desired concentrate output requires the pump to operate at an rpm that is lower than its capabilities.
7 Transfer line	This line allows you to transfer or relay concentrate to another location.
8 DLA	This manages the concentrate injected into the solution-capable discharge.
9 Solution-capable discharge	This transports clear water and is capable of creating a foam solution.

## Installing the DLA Identification Labels

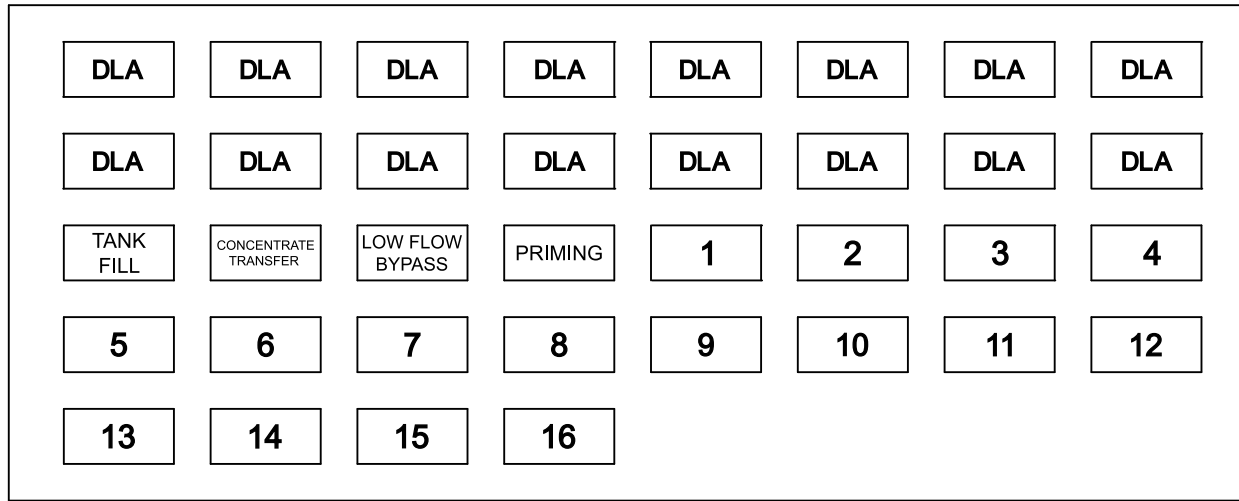

Use the labels provided with the install kit to identify the DLAs.

Apply the appropriate label to the DLA as you install it. In the future, use the label to identify the DLA during setup, service, and maintenance. Use the table below to match the DLA with the discharge name on the apparatus.

**Note:** *It is important to properly number each DLA as this information will be used to commission and name the discharges in the ULTRAFLOW software. To facilitate setup, labeling both the DLA and its associated circuit breaker is recommended.*

DLA	Control Panel Display Name	Notes
1		
2		
3		
4		
5		
6		
7		
8		
9		
10		
11		
12		
13		
14		
15		
16		

## Notes

## DLA Components and Connections

Use the illustration and table to understand the various cable connections to the DLAs and system power.

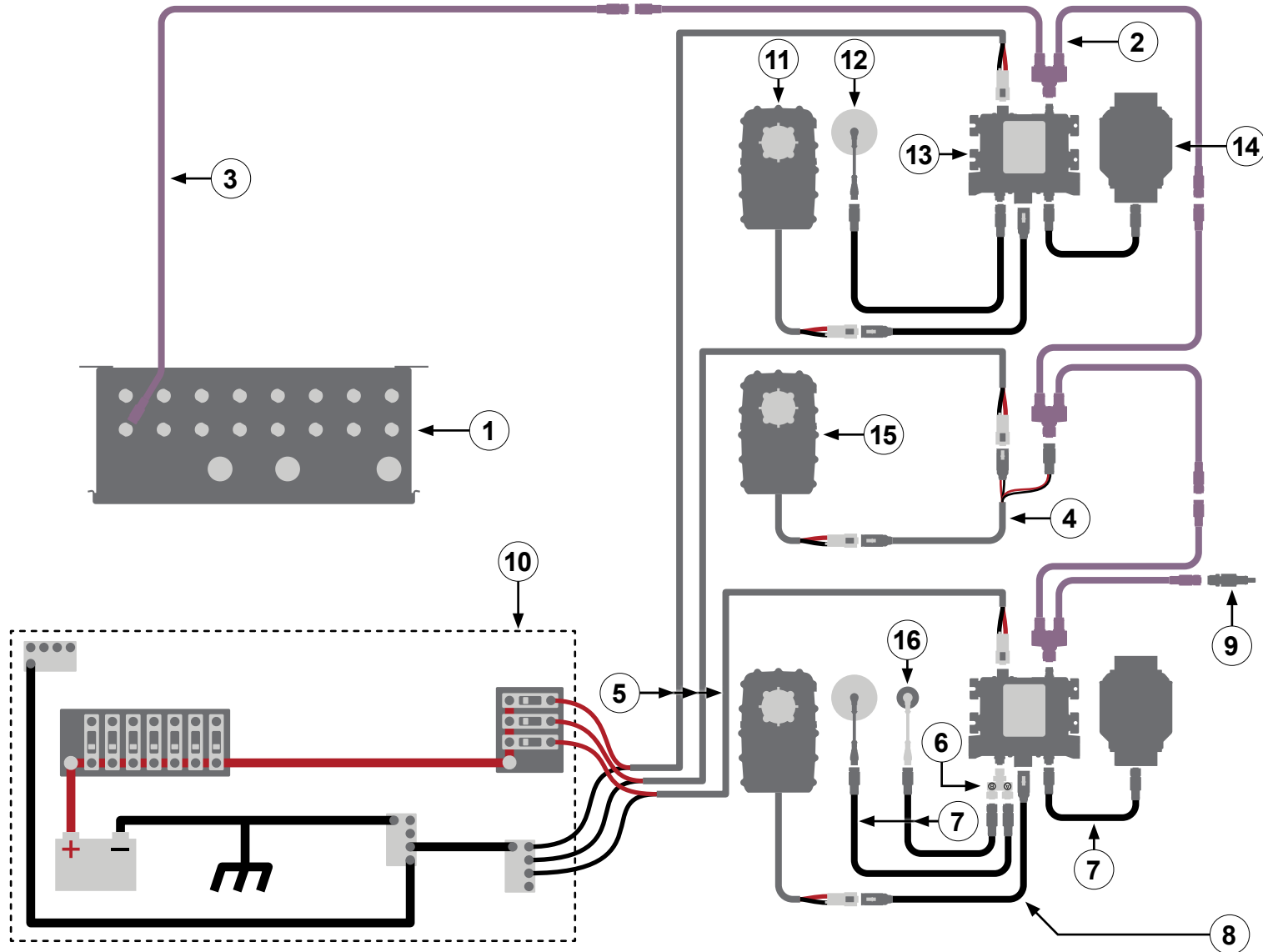

## CAN Cables and Connections

Feature	Description
1 Control box	This connects to various components in the system and contains the PLCs.
2 CAN cable splitter	This passes CAN commands to the next node controller in the chain.
3 CAN cable	This connects the node controllers to one another and the control box.
4 Priming valve power cable	This connects the priming valve to power and CAN control.
5 DLA cable	This supplies power to the DLA and requires a 10 A circuit breaker per DLA—installer-supplied.
6 Y-splitter	This splits the M12 connection to allow flowmeter communication on pin 4 and pump discharge pressure transducer communication on pin 2. <b>Note:</b> Use this when the water pump discharge pressure is not supplied to the system.
7 Sensor cable	This connects the components equipped with M12 connectors—0.5 meter or 2.0 meter.
8 Valve motor cable	This connects the DLA control valve to the node controller.
9 Terminating resistor	This terminates the CAN signal.
10 System power	This is the system power.
11 Concentrate control valve	This controls the concentrate flow.
12 Paddlewheel flowmeter	This measures the flow at the discharge—water and solution.
13 Node controller	This connects to the concentrate control valve, flowmeters, and additional DLAs.
14 Magnetic flowmeter	This measures the concentrate flow.
15 Priming valve	This allows air to evacuate when priming the concentrate pump.
16 Pressure transducer	This measures the line pressure.

## Connecting the 1-Inch DLA

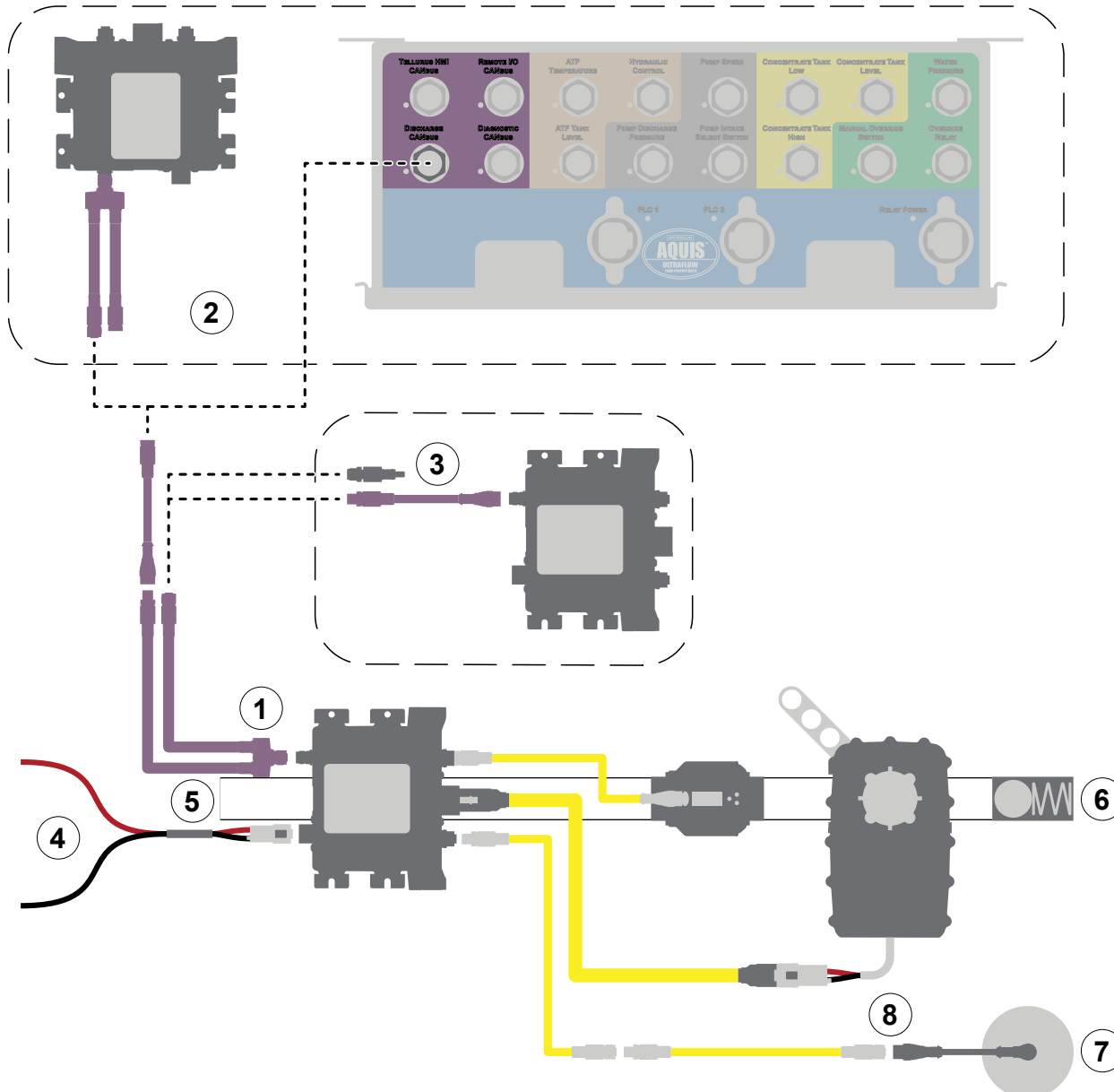

Use the illustration and instructions to install the 1-inch DLA. To connect to the apparatus plumbing, refer to: "**Plumbing Layout**" on page 34.

- 1 Connect the CAN cable splitter to the CAN connector on the node controller.
- 2 Connect the CAN cable splitter to an upstream node controller or to the control box—discharge CANbus connector.
- 3 Connect the CAN cable splitter to the next downstream node controller, or to a terminating resistor if this is the last downstream node controller in the system.
- 4 Locally source a DT06-2S connector and an appropriate cable to connect apparatus power to the node controller. Use a 10 A circuit breaker to power the node controller.
- 5 Connect the DLA inlet to the concentrate supply.
- 6 Connect the DLA outlet to the discharge.
- 7 Install the paddlewheel flowmeter into the associated discharge upstream of the DLA outlet connection.  
**Note:** You must install the flowmeter away from turbulent flow and follow the manufacturer's instructions to receive accurate measurements.
- 8 Use a sensor cable to connect the node controller to the paddlewheel flowmeter.



## Connecting the 2-Inch DLA

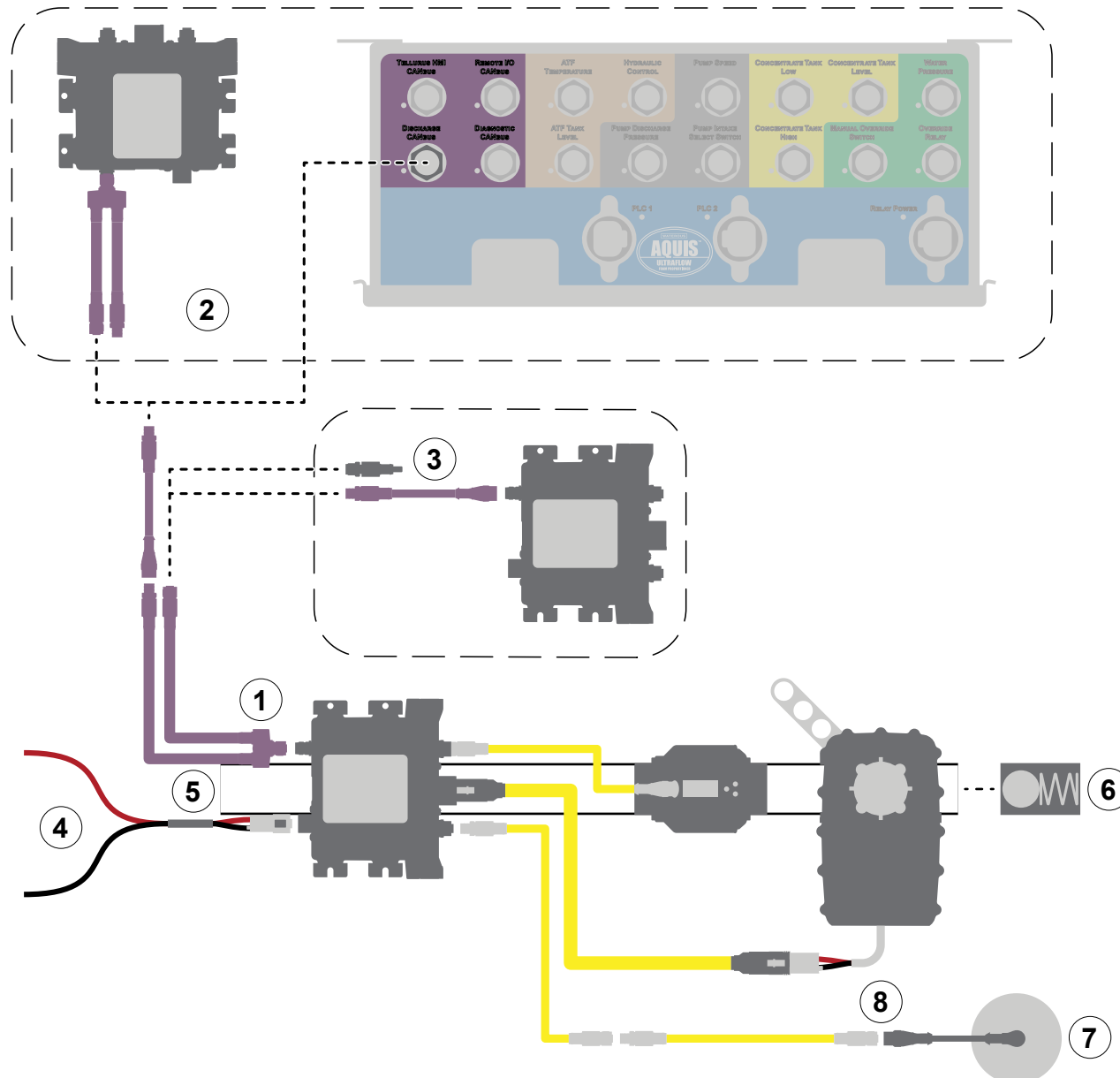

Use the illustration and instructions to install the 2-inch DLA. To connect to the apparatus plumbing, refer to: **"Plumbing Layout" on page 34.**

- 1 Connect the CAN cable splitter to the CAN connector on the node controller.
- 2 Connect the CAN cable splitter to an upstream node controller or to the control box—discharge CANbus connector.
- 3 Connect the CAN cable splitter to the next downstream node controller, or to a terminating resistor if this is the last downstream node controller in the system.
- 4 Locally source a DT06-2S connector and an appropriate cable to connect apparatus power to the node controller. Use a 10 A circuit breaker to power the node controller.
- 5 Connect the DLA inlet to the concentrate supply.
- 6 Install the check valve to the DLA, then connect the DLA outlet to the discharge.
- 7 Install the paddlewheel flowmeter into the associated discharge upstream of the DLA outlet connection.  
**Note:** Refer to the manufacturer's instructions to properly install the paddlewheel in your application.
- 8 Use a sensor cable to connect the node controller to the paddlewheel flowmeter.

## Connecting the Priming Valve

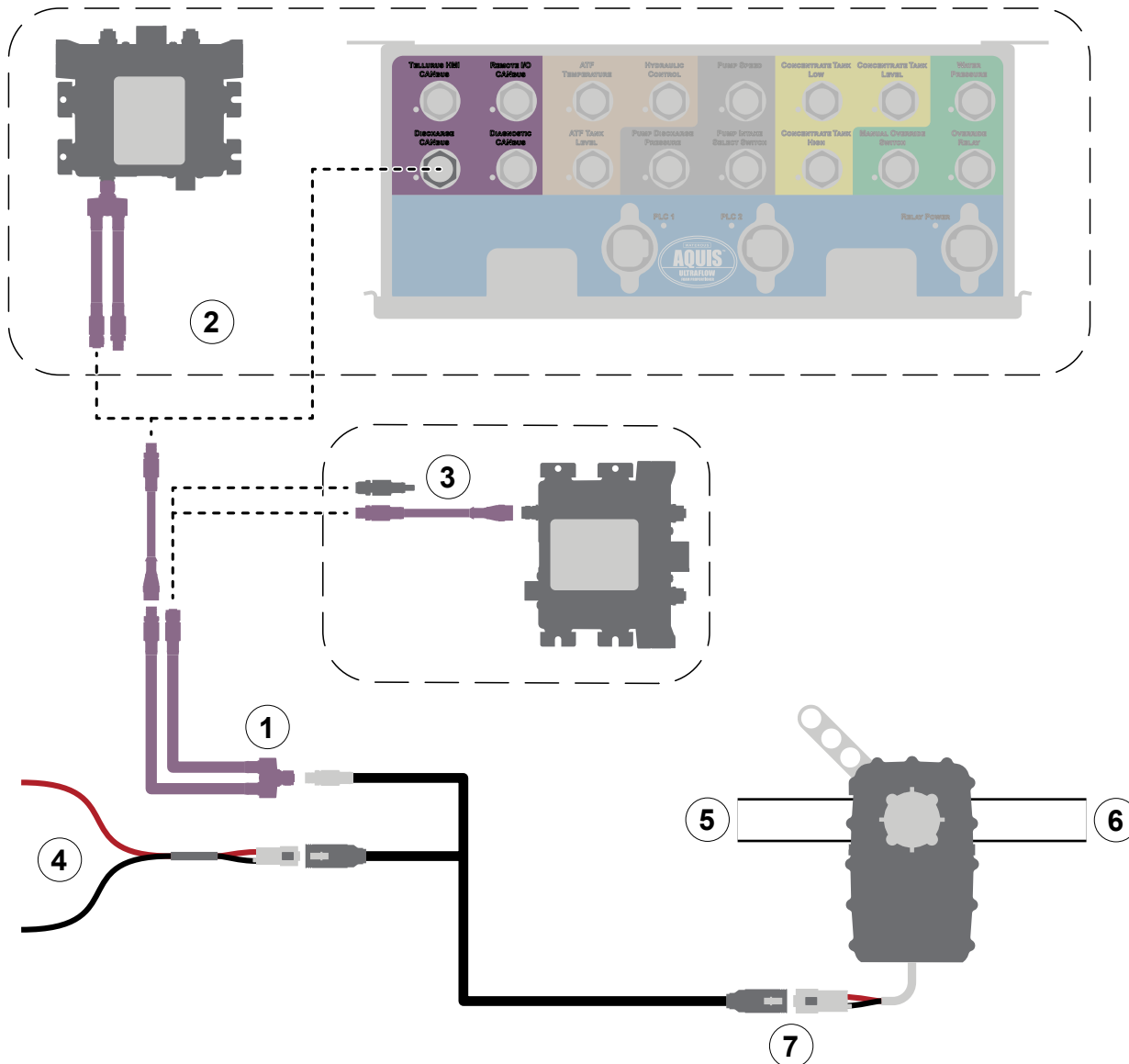

Use the illustration and instructions to install the priming valve. To connect to the apparatus plumbing, refer to: **"Plumbing Layout" on page 34.**

- 1 Connect the CAN cable splitter to the CAN connector on the priming valve motor cable.
- 2 Connect the CAN cable splitter to an upstream node controller or to the control box—discharge CANbus connector.
- 3 Connect the CAN cable splitter to the next downstream node controller, or to a terminating resistor if this is the last downstream node controller in the system.
- 4 Locally source a DT06-2S connector and an appropriate cable to connect apparatus power to the priming valve motor cable. Use a 10 A circuit breaker to power the priming valve motor.
- 5 Connect the priming valve inlet to the discharge side of the concentrate pump.
- 6 Connect the priming valve outlet to the concentrate supply tank, through the installer-supplied prime-bypass valve.
- 7 Connect the priming valve motor cable to the priming valve.

## Connecting the Low-Flow Bypass Line

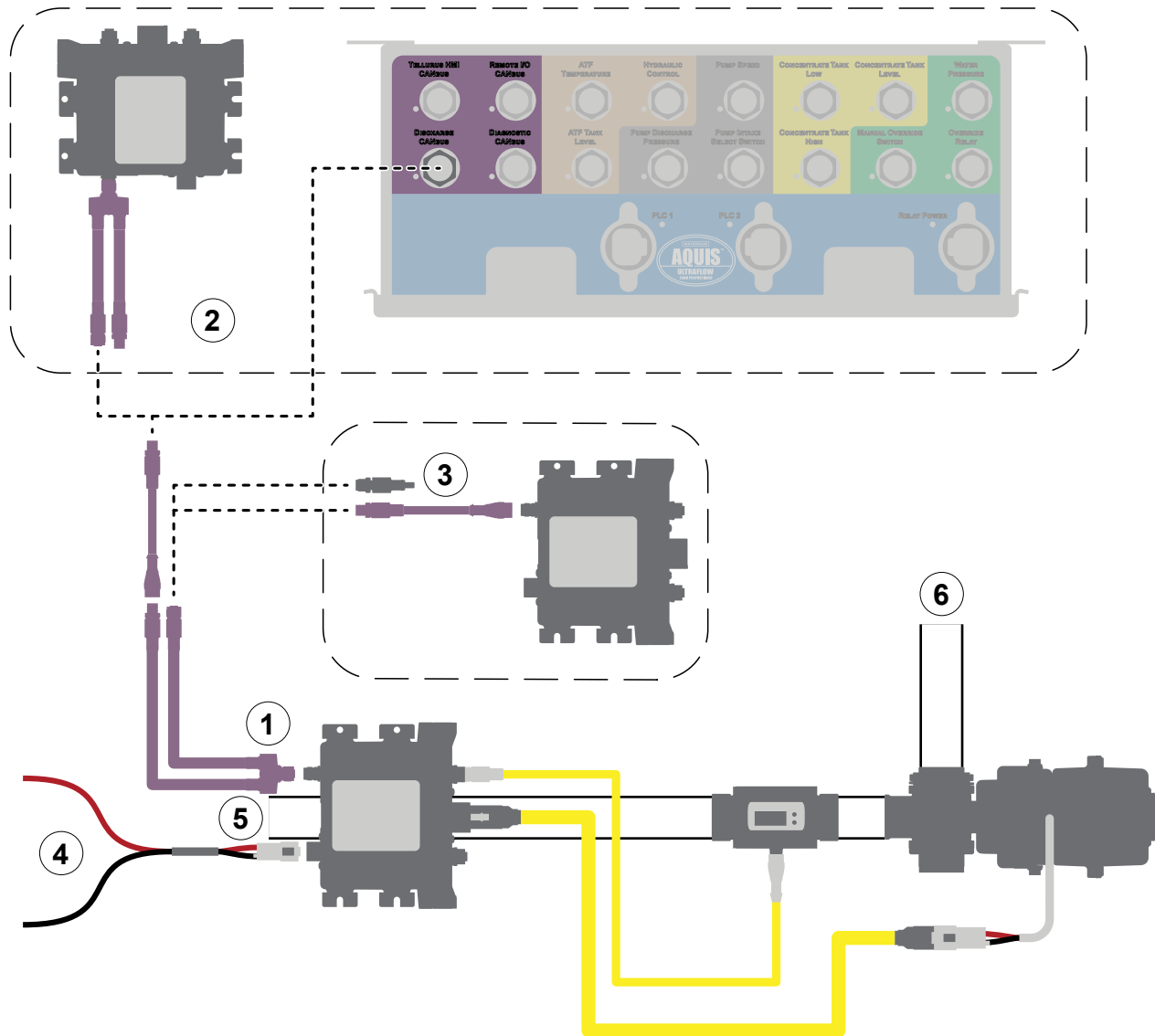

Use the illustration and instructions to install the low-flow bypass line. To connect to the apparatus plumbing, refer to: **"Plumbing Layout" on page 34.**

- 1 Connect the CAN cable splitter to the CAN connector on the node controller.
- 2 Connect the CAN cable splitter to an upstream node controller or to the control box—discharge CANbus connector.
- 3 Connect the CAN cable splitter to the next downstream node controller, or to a terminating resistor if this is the last downstream node controller in the system.
- 4 Locally source a DT06-2S connector and an appropriate cable to connect apparatus power to the node controller. Use a 10 A circuit breaker to power the node controller.
- 5 Connect the low-flow bypass line inlet end to the discharge side of the concentrate pump.
- 6 Connect the low-flow bypass line outlet end to the inlet side of the concentrate pump.

## Connecting the Supply Tank Fill Line

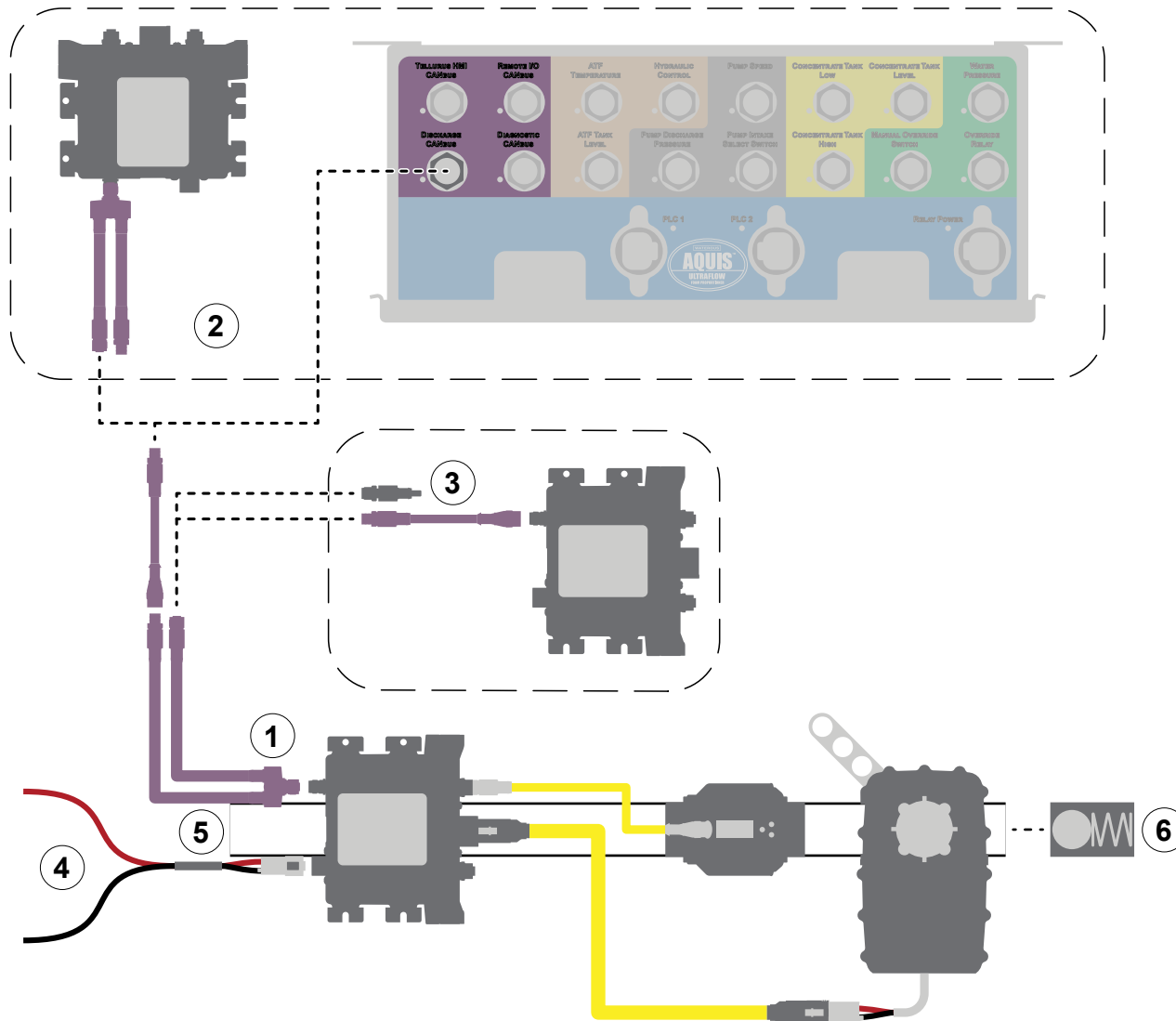

Use the illustration and instructions to install the supply tank fill line. To connect to the apparatus plumbing, refer to: **"Plumbing Layout" on page 34.**

- 1 Connect the CAN cable splitter to the CAN connector on the node controller.
- 2 Connect the CAN cable splitter to an upstream node controller or to the control box—discharge CANbus connector.
- 3 Connect the CAN cable splitter to the next downstream node controller, or to a terminating resistor if this is the last downstream node controller in the system.
- 4 Locally source a DT06-2S connector and an appropriate cable to connect apparatus power to the node controller. Use a 10 A circuit breaker to power the node controller.
- 5 Connect the supply tank fill line to the concentrate supply.
- 6 Install the check valve, then connect the supply tank fill line to the apparatus plumbing.

## Connecting the Y-Splitter—Alternate Discharge Pressure

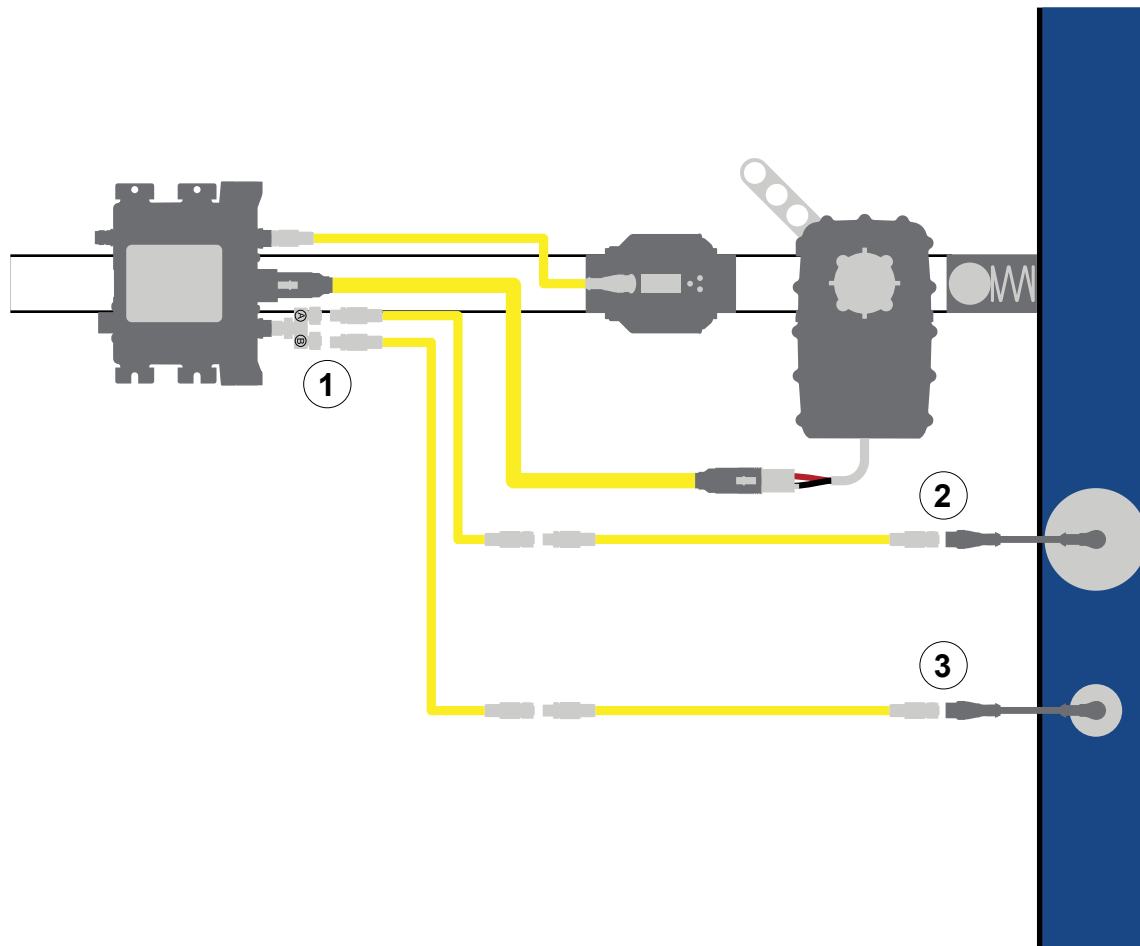

Use the illustration and instructions to install the Y-splitter when measuring the discharge pressure at the solution-capable discharge.

- 1 Connect the Y-splitter to the node controller.
- 2 Connect the paddlewheel flowmeter that is installed in the solution-capable discharge to the A-connector on the Y-splitter.
- 3 Connect the solution discharge pressure transducer to the B-connector on the Y-splitter.

## Installing the Transmitter and Flowmeter

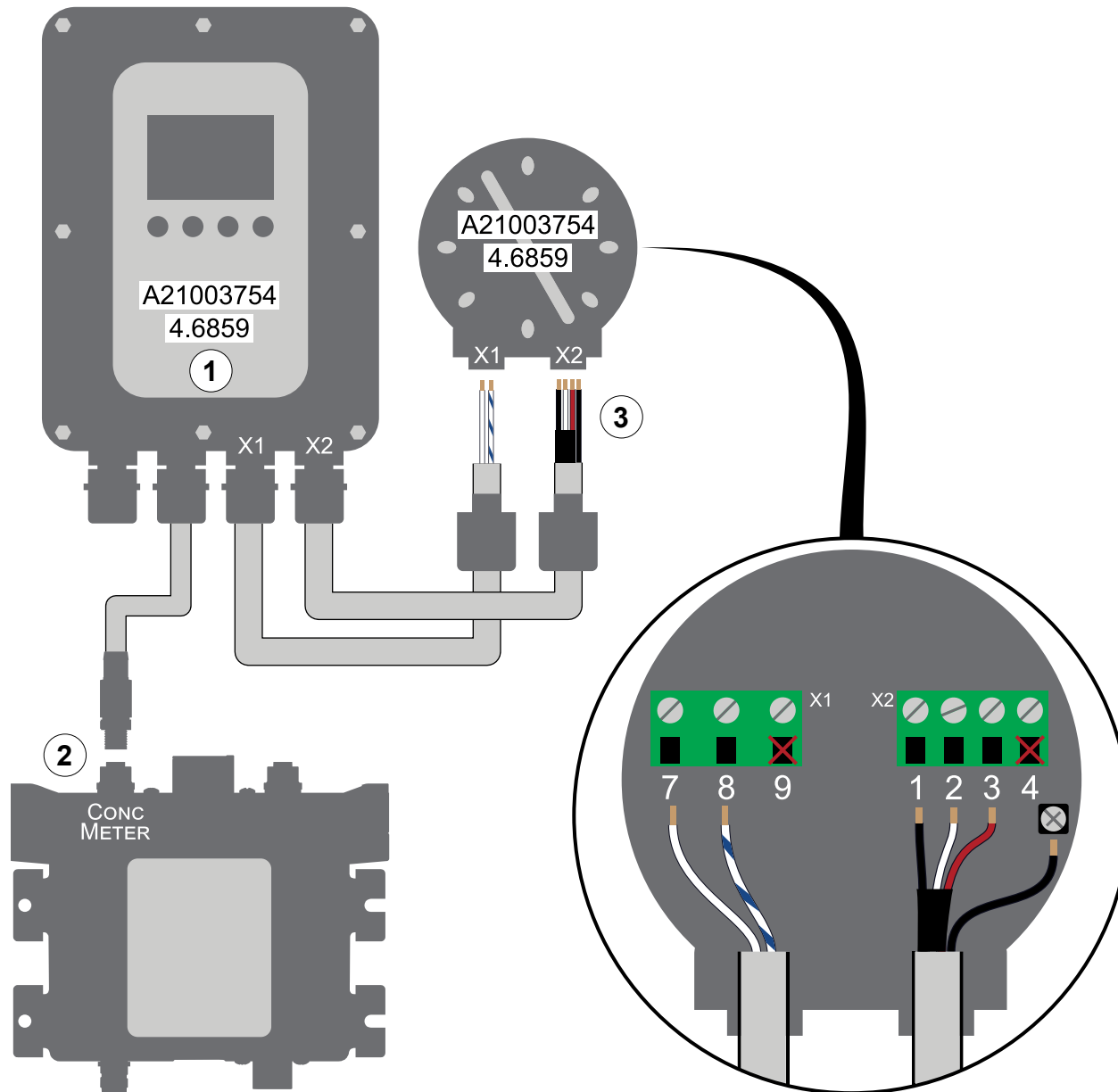

Use the illustration and instructions to install the transmitter and flowmeter. To connect the flowmeter to the apparatus plumbing, refer to: **"Plumbing Layout" on page 34**. Mount the transmitter close to the DLA and make sure that it is accessible for setup and maintenance. The transmitter is wired at the factory and only requires the wire leads to be connected to the flowmeter.

- 1 Make sure that the numbers on the transmitter and flowmeter match.
- 2 Connect the M12 connector to the node controller—Conc Meter.
- 3 To wire the flowmeter, do the following:
  - Remove the top cover from the flowmeter and locate the cable glands.
  - Route the cables through the cable glands and into the flowmeter.
  - Install the cable glands to secure the cables. Leave enough room to install the wire leads.
  - Secure the wire leads to the terminal blocks and ground screw.
  - Install the top cover.

## Wiring the Transmitter and Flowmeter—Custom Cable Length

Only use the following information if your application requires custom-length cables where cable extensions are not available.

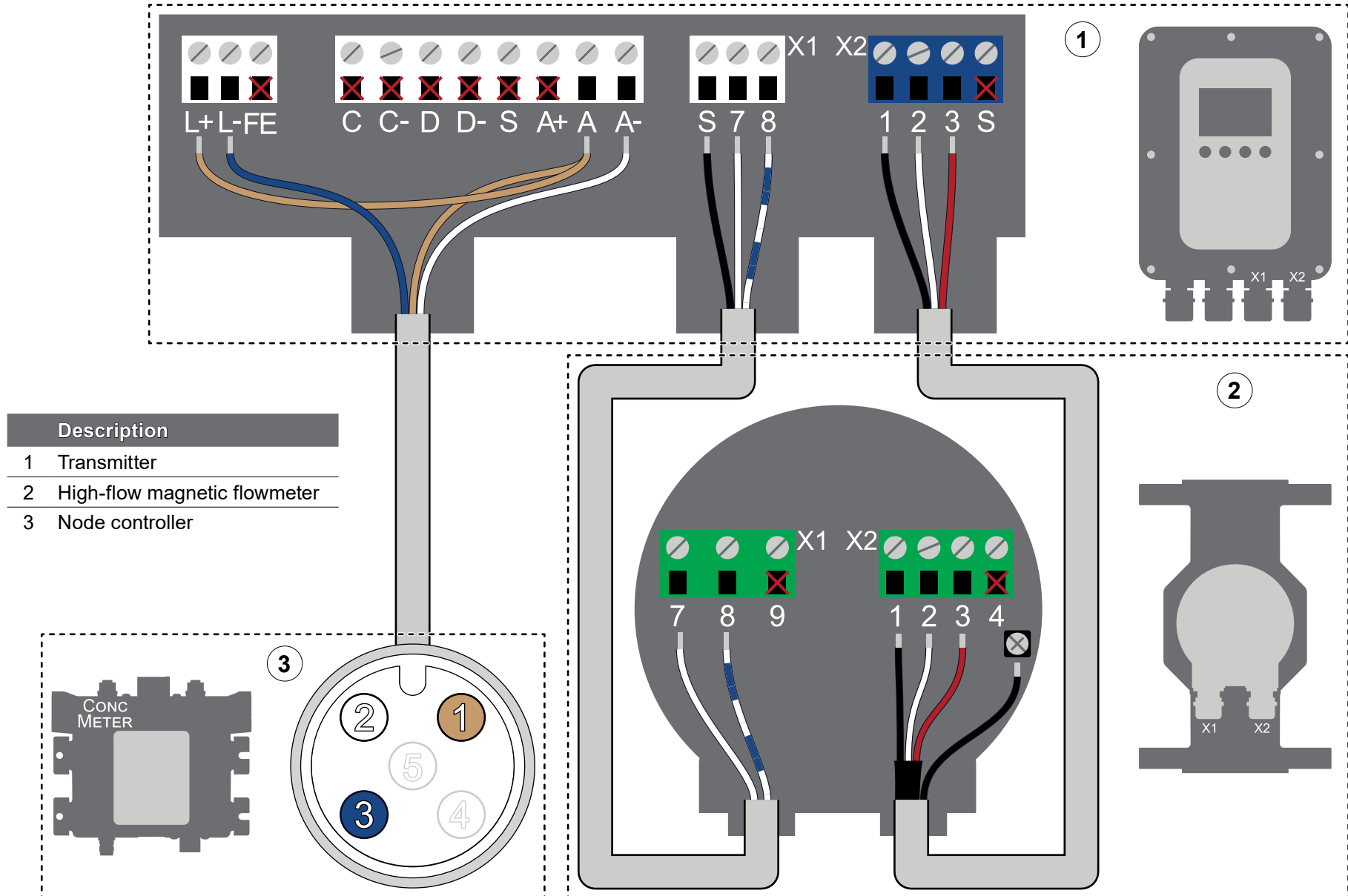

## X1 Cable Schematic—Custom Cable Length

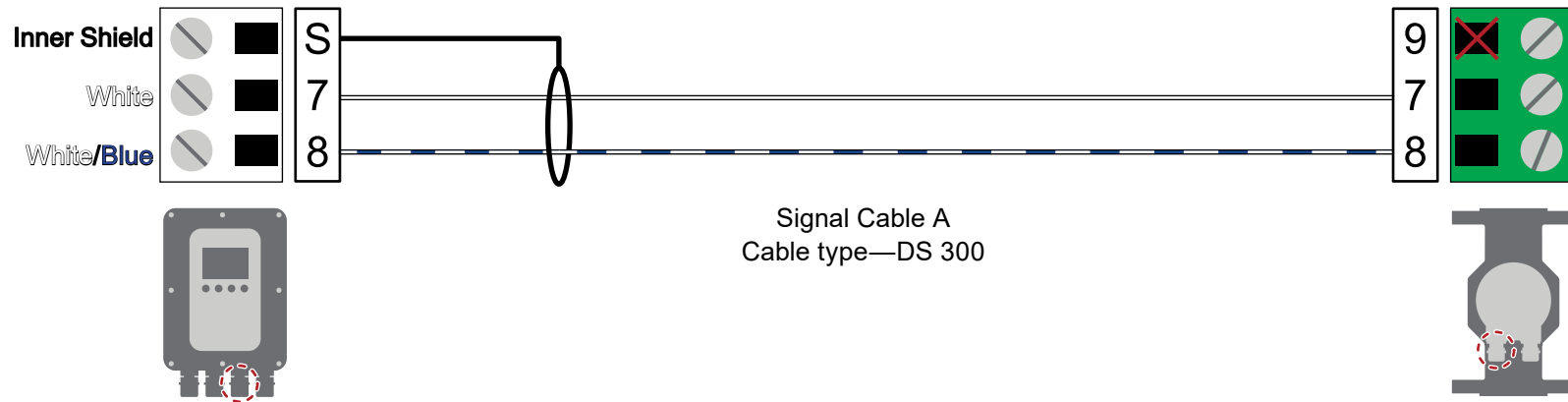

## X2 Cable Schematic—Custom Cable Length

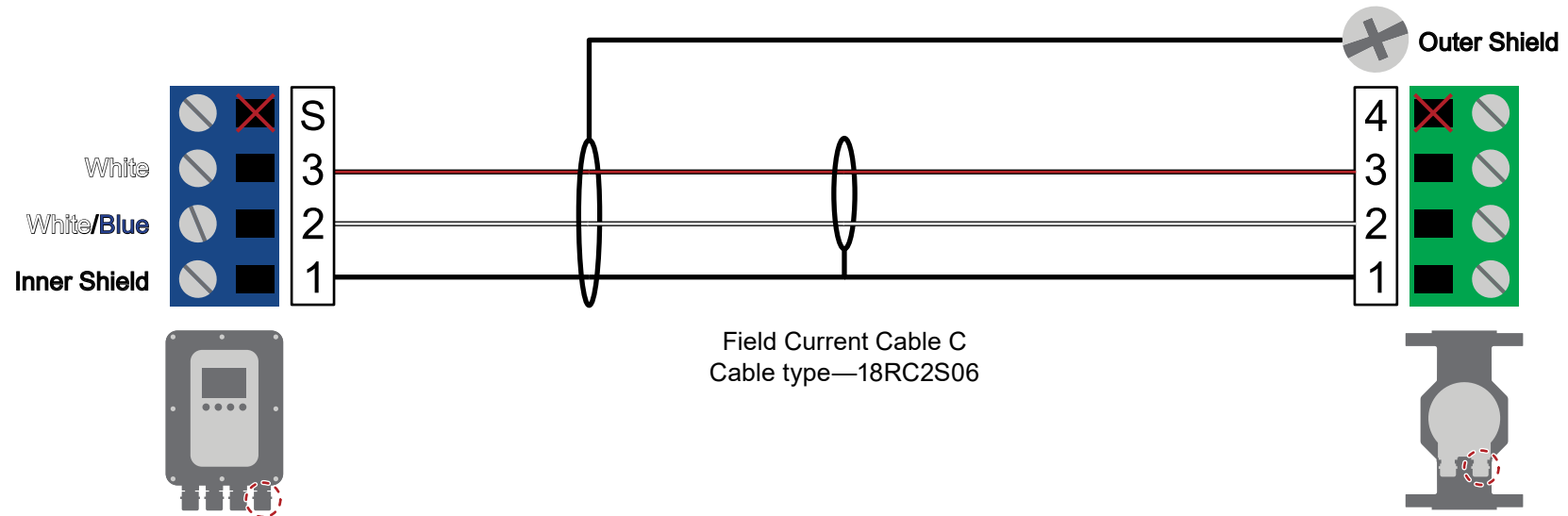



## Operation Overview

This equipment is intended to be operated by a person or persons that have been trained in its operation.

## Preparing for the Operation

Use the following guidelines before operation:

- Read and understand all the instructions before operating the system.
- Make sure that the system is tested and calibrated before operation.
- Make sure that you are trained on the system before operation.

## NOTICE

### Before Operation

- Read and understand all the instructions provided.
- Check all fluid levels and replenish if necessary.
- Remove all shipping plugs and install the operation plugs or caps.



## During Operation

Use the following guidelines before operation:

- Use industry best practices when you operate the system.
- Only allow trained personnel to operate the system.
- When water is substituted for concentrate during training or testing and there is concentrate in the supply tank, use the bypass valve to prevent water from contaminating the concentrate supply.

**Note:** You must drain any remaining water in the line before priming the system with concentrate to prevent contamination.

## NOTICE

### Concentrate Supply Contamination

- Priming with water can contaminate the on-board concentrate supply.
- Divert water to prevent concentrate contamination.

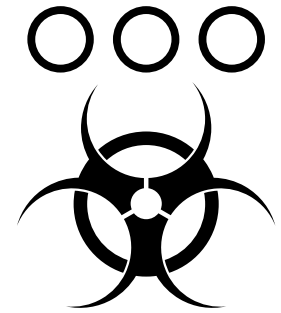

## After Operation

Use the following guidelines after operation:

- Flush any residual concentrate from the apparatus plumbing.
- Drain all lines when freezing can occur.

## NOTICE

### Freeze Damage

- Do not allow fluid in the lines to freeze.
- Remove all freezable fluid from the lines before storing the apparatus.

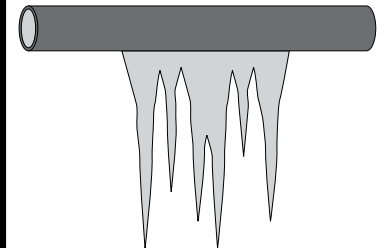

## Enabling and Disabling a Discharge

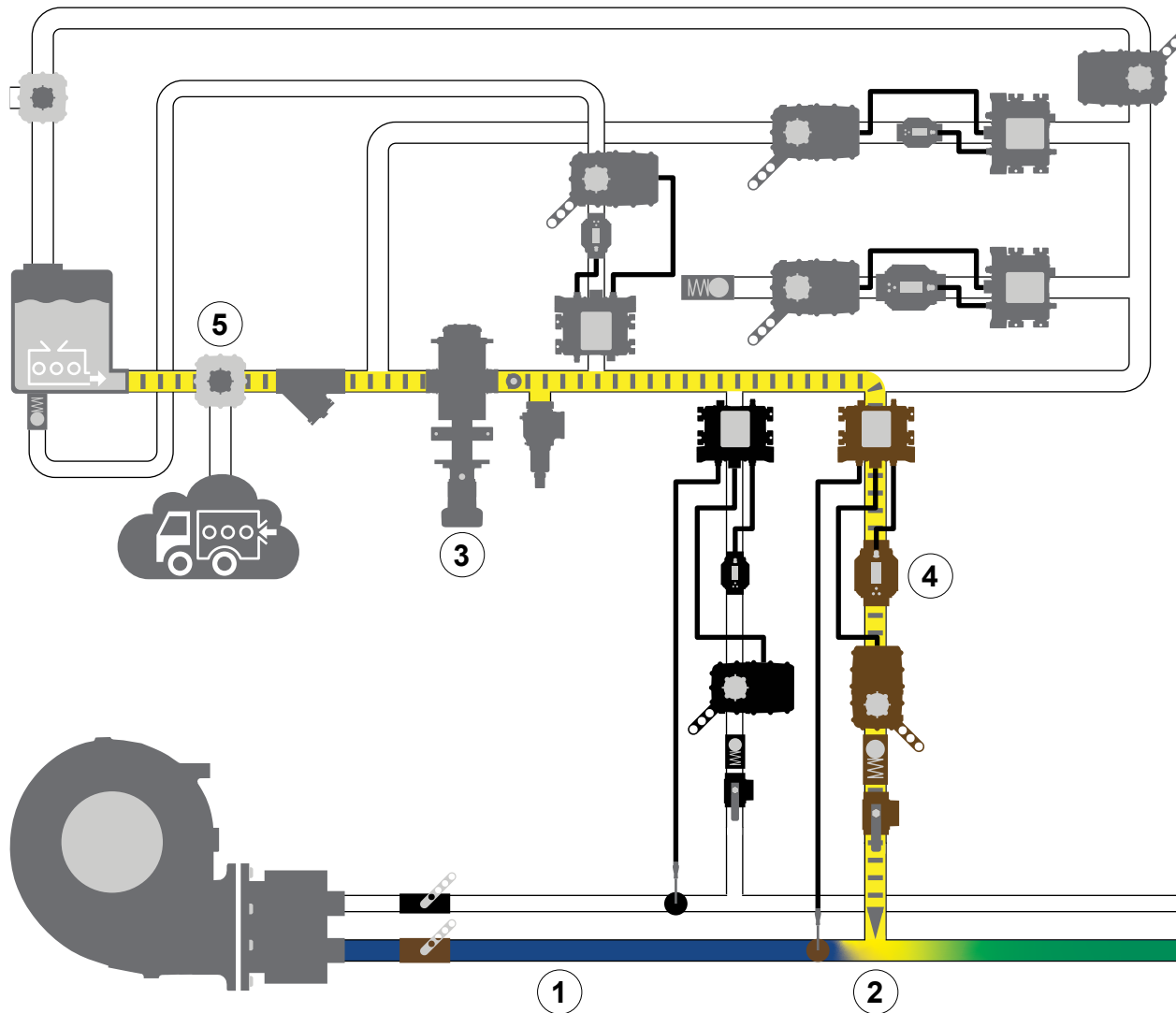

Use the illustration and instructions to understand the system activity when you enable a DLA. Remember that an enabled DLA is only active when the associated line is flowing water.

**Note:** *The illustration only focuses on the activity in the system that best conveys the process.*

- 1 The fire pump flows water into the discharge.
- 2 The enabled DLA measures the water flow in the discharge.
- 3 The concentrate pump activates.
- 4 The magnetic flowmeter measures the amount of concentrate flowing in the DLA while the valve meters the concentrate proportioned into the discharge to produce the selected solution.
- 5 The concentrate source is selected by the concentrate source valve. The valve switches between an on-board or auxiliary concentrate source. The valve position is provided to the system, which allows or prohibits certain functions.

## Switching the Concentrate Source Mode—System View

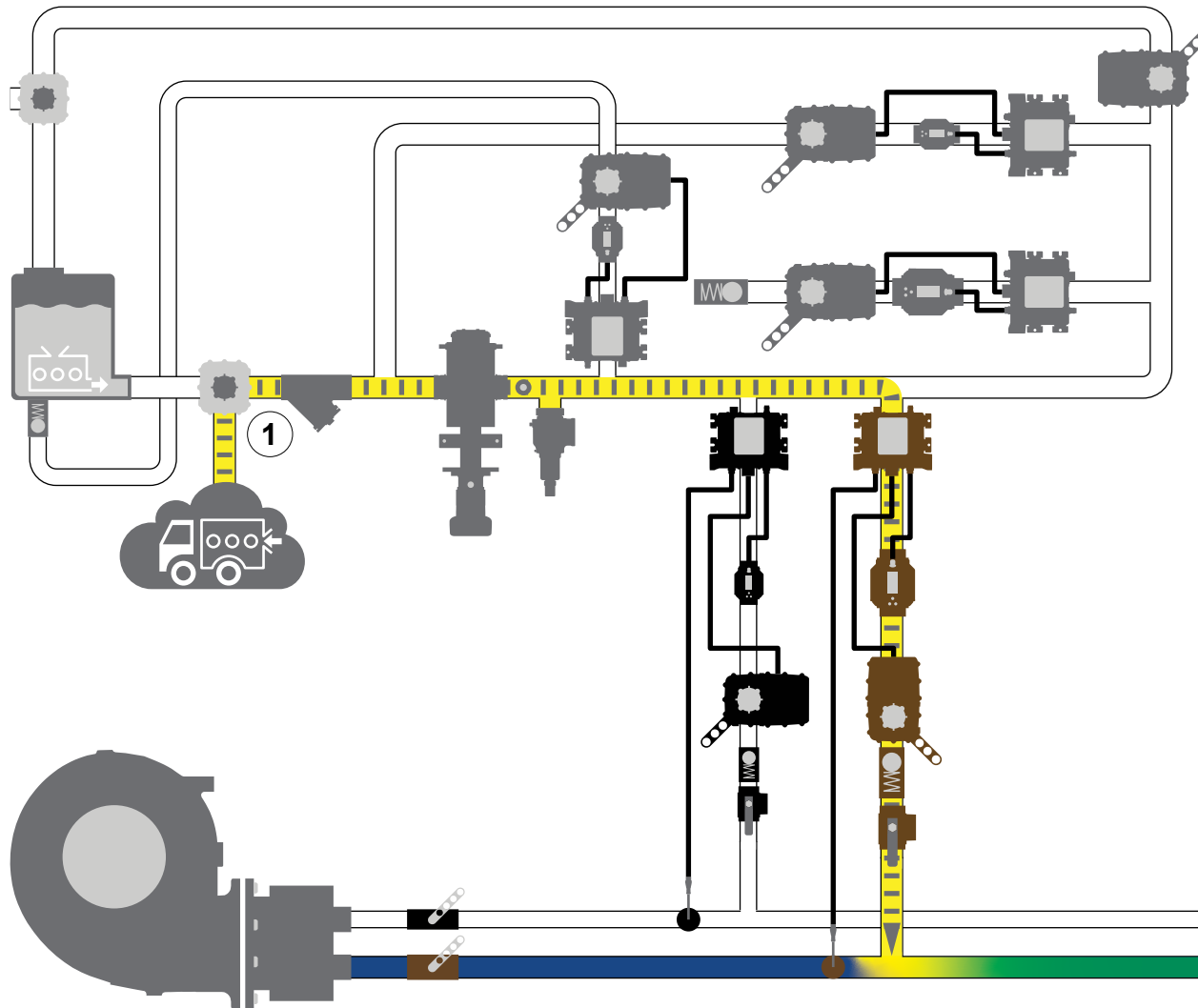

Use the illustration and instructions to understand the system activity when you set it to an auxiliary concentrate source.

**Note:** *The illustration only focuses on the activity in the system that best conveys the process.*

- 1 When set to auxiliary supply mode, a valve is used to change the concentrate source from the on-board supply tank to the auxiliary system. When sourcing concentrate from an auxiliary source, the system cannot measure the supply level—the concentrate supply must be managed by the operator.

The auxiliary source valve and components required to integrate with the control box are installer-supplied.

**Note:** *Do not operate the equipment without providing concentrate or water to pump through the system.*

## Refilling the On-Board Supply Tank—Screen View

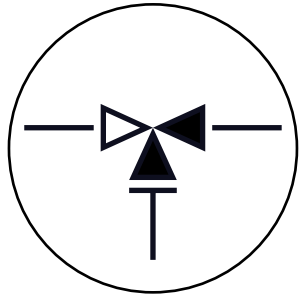

1

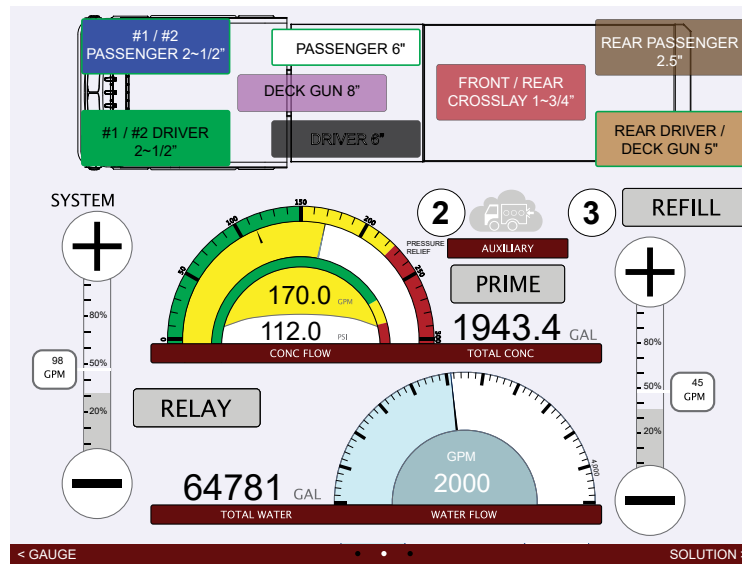

Use the illustrations and instructions to refill the on-board concentrate supply tank from an auxiliary source. This is useful when manually refilling the on-board supply tank is not practical. Refilling the on-board supply tank can take place concurrently with normal discharge operations.

- 1 Set the concentrate supply source to auxiliary.
- 2 Verify that the concentrate supply icon shows that auxiliary supply is selected.
- 3 Press the *REFILL* button to start the process. The system stops when the concentrate supply tank is full.
- 4 The *REFILL* button changes appearance and the concentrate supply icon begins to animate when the refill process is active.
- 5 Adjust the slider to the desired refill rate.

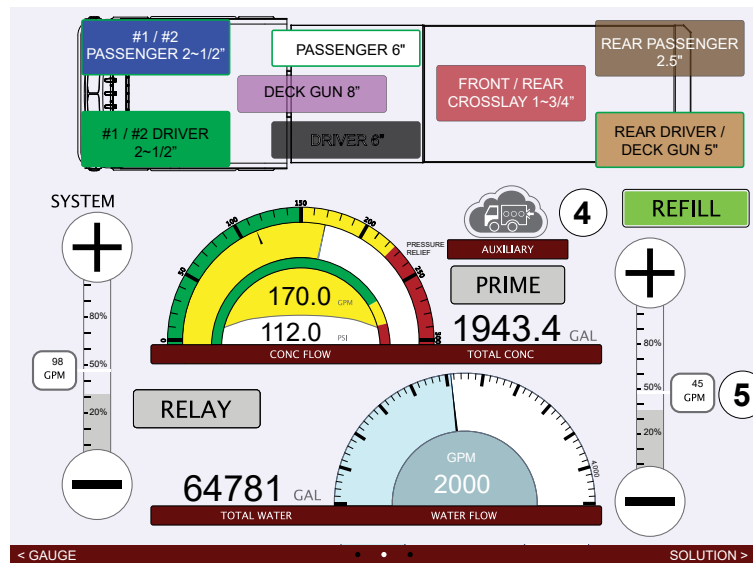

## Refilling the On-Board Supply Tank—System View

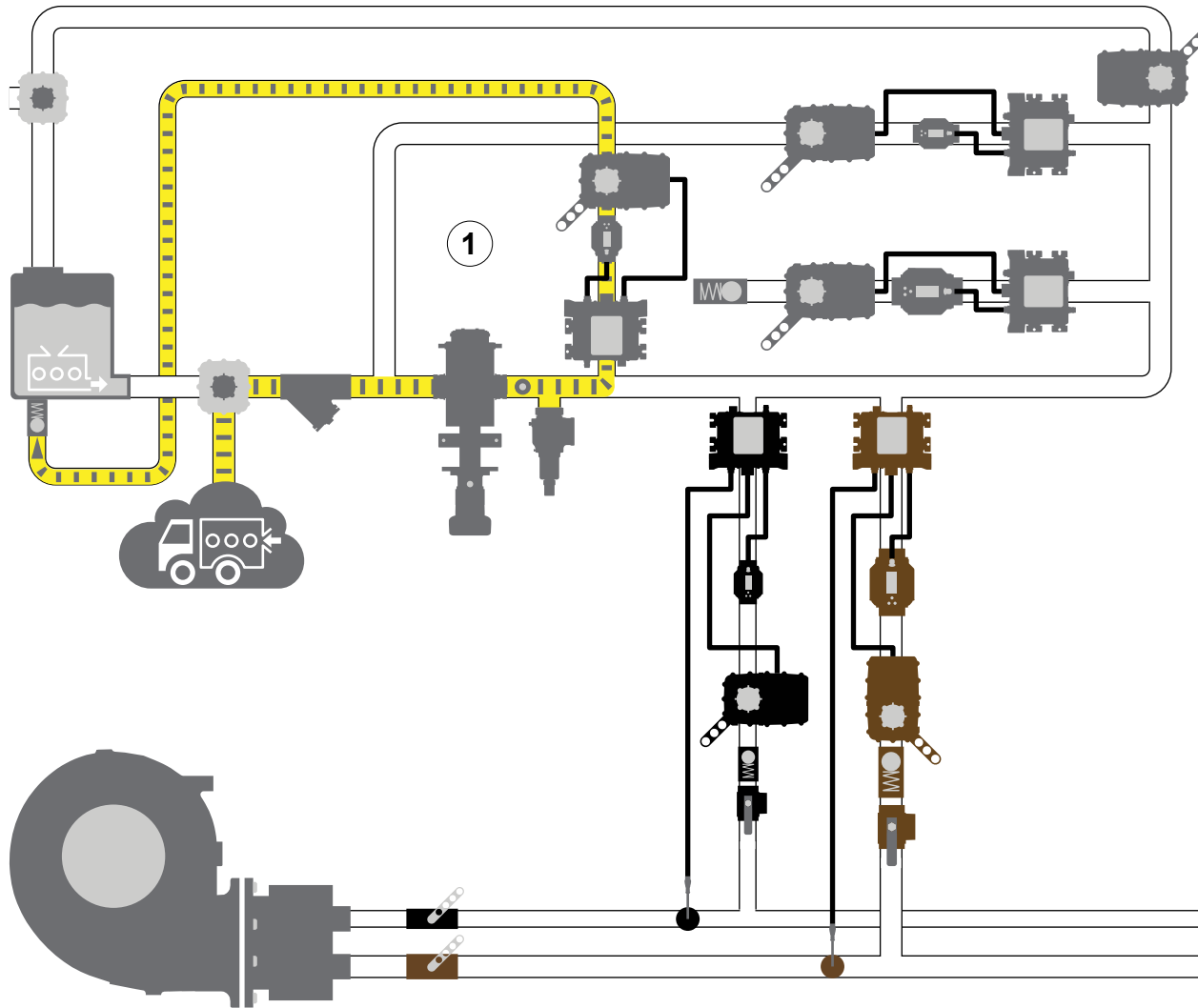

Use the illustration and instructions to understand the system activity when you refill the on-board concentrate supply tank. You can operate the discharges while refilling the tank.

**Note:** *The illustration only focuses on the activity in the system that best conveys the process.*

- 1 The system sources concentrate from the auxiliary concentrate supply. Concentrate is pumped into the on-board supply tank until the supply level system determines the tank is full.

**Note:** *Make sure that you provide enough concentrate to fill the on-board supply tank or manually stop pump operation before the auxiliary concentrate supply runs out.*

## Understanding Priming

Each UltraFlow application is unique. On the whole, the system is straightforward. However, with regard to priming the system, there are conditions that you should be aware of when designing your application. Understanding these conditions will also help you develop a standard operating procedure to prime and operate the system. Refer to "**Plumbing Layout**" on page 34 to help visualize the following concepts.

Once enabled, the system can automatically or manually prime the concentrate manifold before operation. To prime the concentrate manifold, the system opens the priming valve to allow air to escape as concentrate fills the pump. The priming valve closes when the pressure requirement in the concentrate manifold is reached. As the valve closes, some amount of concentrate follows the escaping air past the priming valve. This is not an issue when the priming line is plumbed back to the on-board tank or external reservoir, collecting any escaping concentrate.

## Understanding Over-Pressure Events

 <b>WARNING</b>	
<p><b>High Pressure</b></p> <ul style="list-style-type: none"> <li>• Discharge ejected at high pressure can cause serious injury and damage.</li> <li>• Direct discharge away from people and equipment.</li> </ul>	

An over-pressure event is an event that causes concentrate to discharge into the on-board tank or external reservoir at a high pressure. Typically two conditions cause over-pressure events: the pressure relief valve is activated or you manually over-prime the system.

In either case, it is important to understand and manage the event, and design the system plumbing to manage such an event if it occurs.

Know what pressure the pressure relief valve discharges at and how it affects the plumbing layout in your application. Understand how priming the system manually could circulate concentrate back to the on-board tank at a high pressure. Understand how to angle the outlet or use a baffle to dissipate and manage the discharge when it is returned to the on-board tank.

Know that when you manually prime the system by pressing and holding the manual prime button, the concentrate pump operates at maximum output. The priming valve opens and remains open while you press the button. Understand that continually operating the concentrate pump after the system is fully primed will discharge the concentrate at a high pressure back to the on-board tank or external reservoir. Develop procedures to prevent over-priming the system.

Finally, it is recommended to initiate priming from the on-board supply tank. This potentially provides a gravity assist while priming and creates space in the on-board tank if over-primed concentrate is returned to the on-board tank.

## Manually Priming the Concentrate Line

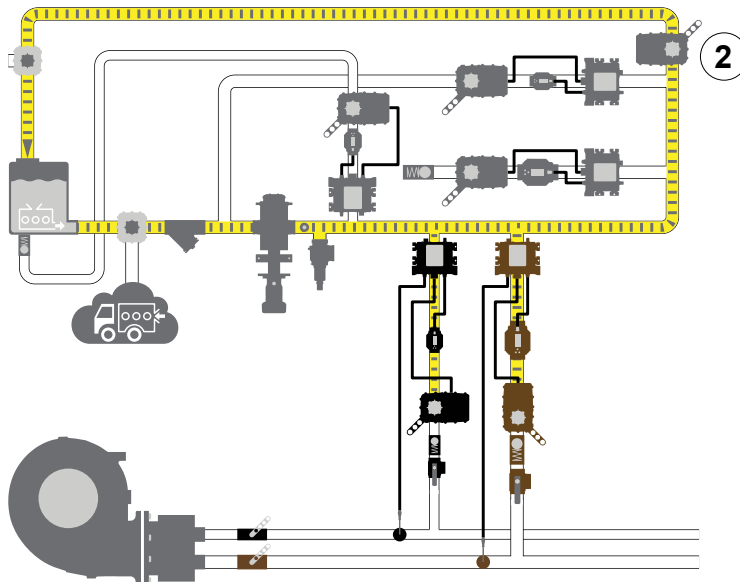
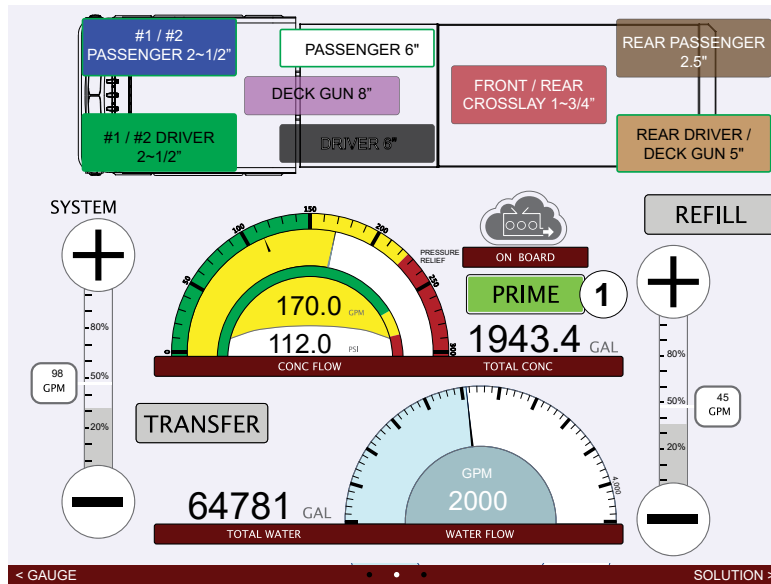

### Priming with Concentrate

Use the illustrations and instructions to manually prime the concentrate line. The system automatically primes before operation. It can also be primed by pressing the *PRIME* button.

**Note:** The illustration only focuses on the activity in the system that best conveys the process.

- 1 Press and hold the *PRIME* button until the system is primed.
- 2 The system evacuates the air in the lines to atmosphere as the concentrate fills the lines. During prime operation a small amount of concentrate will return to the on-board tank. Make sure that the tank capacity is sufficient for normal priming operation.

**Note:** The system can also be primed from an auxiliary concentrate source. However, extended manual priming from an auxiliary supply is not recommended as this may overflow the on-board tank.

## Manually Priming the Concentrate Line

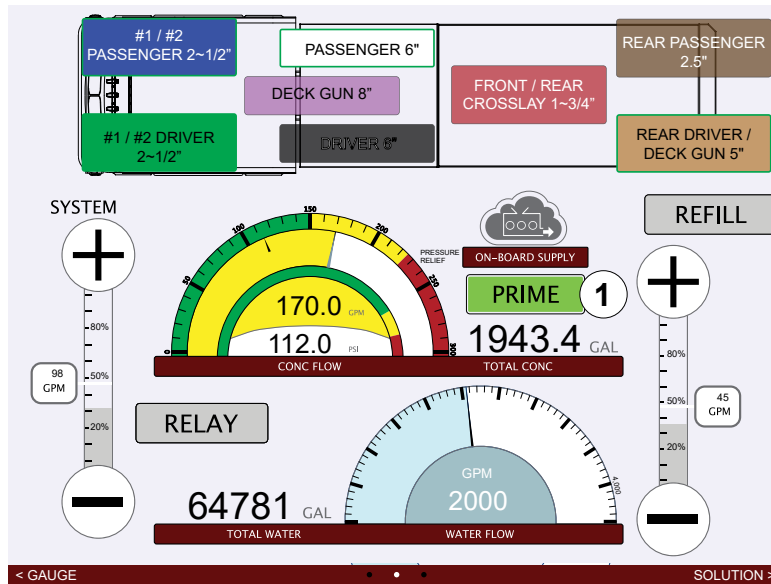

### Priming with Water

Use the illustrations and instructions to manually prime the concentrate line. The system automatically primes before operation. It can also be primed by pressing the *PRIME* button.

**Note:** The illustration only focuses on the activity in the system that best conveys the process.

- 1 Press and hold the *PRIME* button until the system is primed.
- 2 The system evacuates the air in the lines to atmosphere as the water fills the lines.

**!** **Concentrate contamination:** Priming with water will lead to contamination if the priming line is plumbed to evacuate into the concentrate supply tank. To avoid contamination, install a bypass line to divert the water and drain any water in the concentrate line before priming.

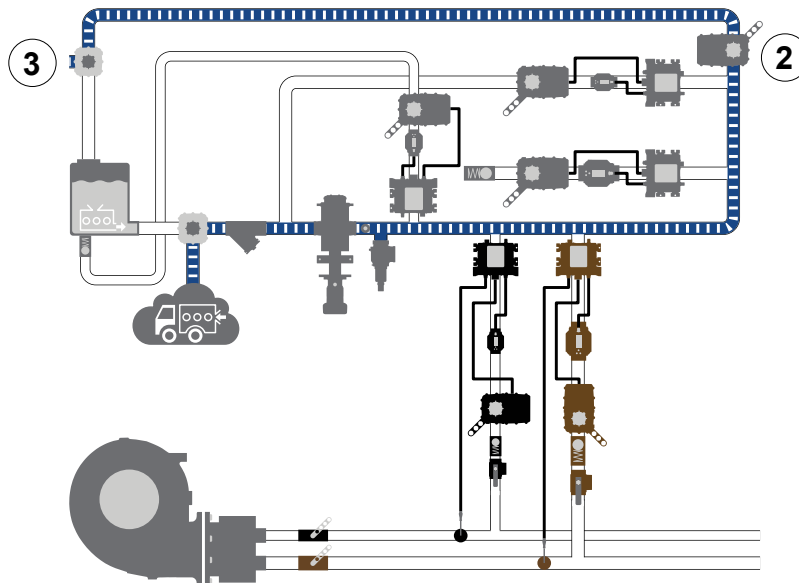



## Transferring Concentrate

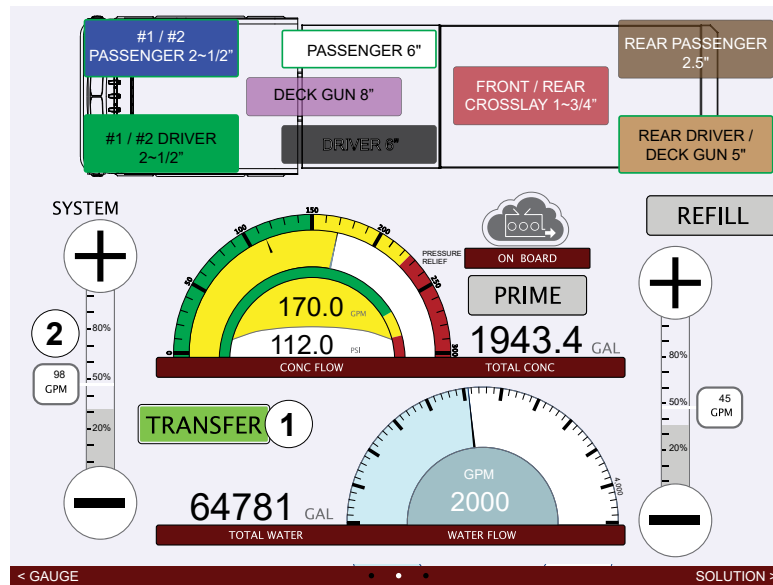

Use the illustrations and instructions to transfer concentrate to another location. If included in your application, you can use the transfer line to move the concentrate from the on-board tank or external source to another location. You can operate the discharges while transferring concentrate.

**Note:** The illustration only focuses on the activity in the system that best conveys the process.

- 1 Press the *TRANSFER* button to begin the transfer process.
- 2 Adjust the slide to the desired transfer rate.
- 3 The system transfers the concentrate from the selected source to the transfer line.

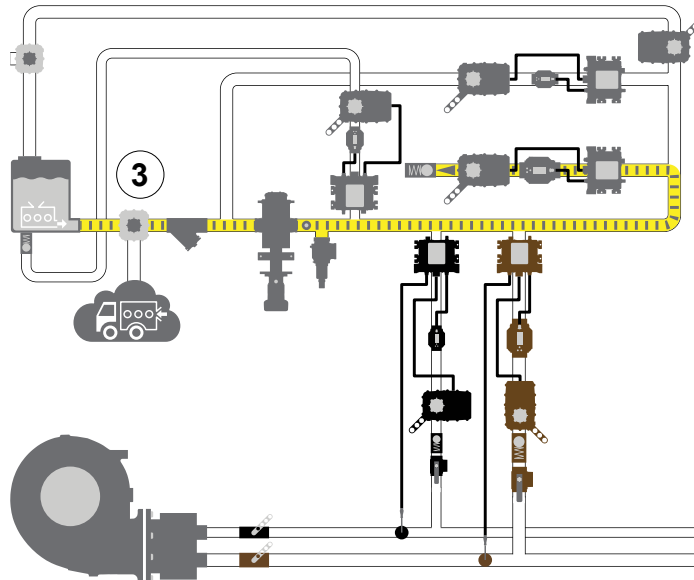

## Relaying Concentrate

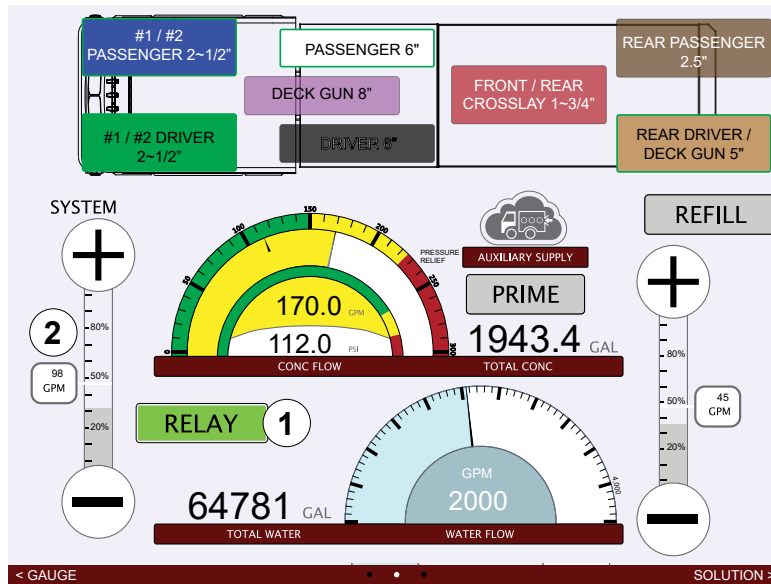

Use the illustrations and instructions to transfer concentrate to another location. If included in your application, you can use the transfer line to move the concentrate from the on-board tank or external source to another location. You can operate the discharges while transferring concentrate.

**Note:** The illustration only focuses on the activity in the system that best conveys the process.

- 1 Press the *RELAY* button to begin the relay process.
- 2 Adjust the slide to the desired relay rate.
- 3 The system relays the concentrate from an auxiliary source to the transfer line.

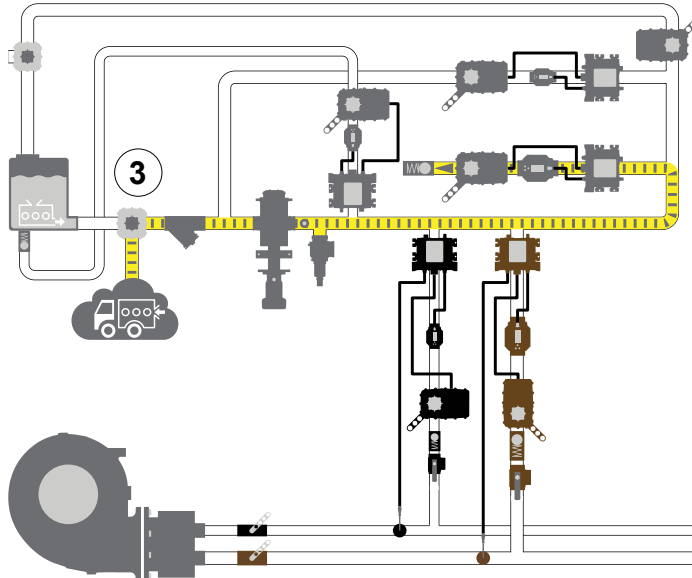

## Flushing the Apparatus Plumbing

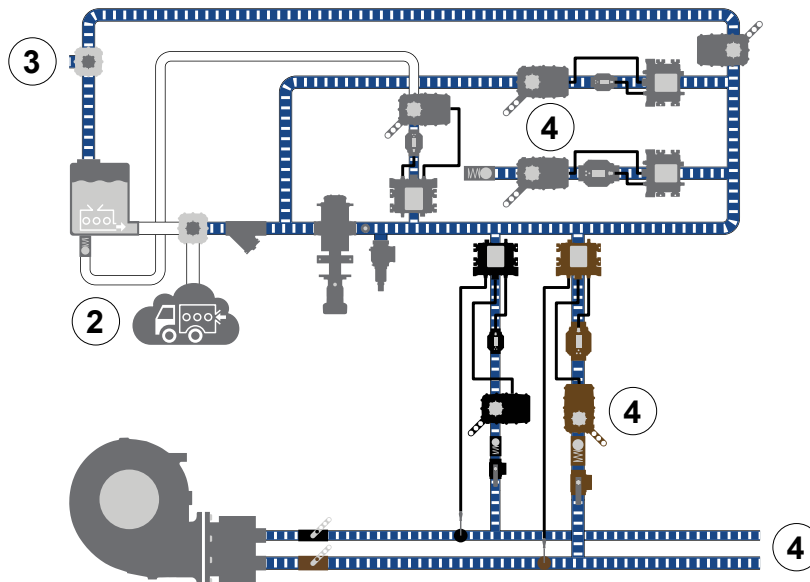
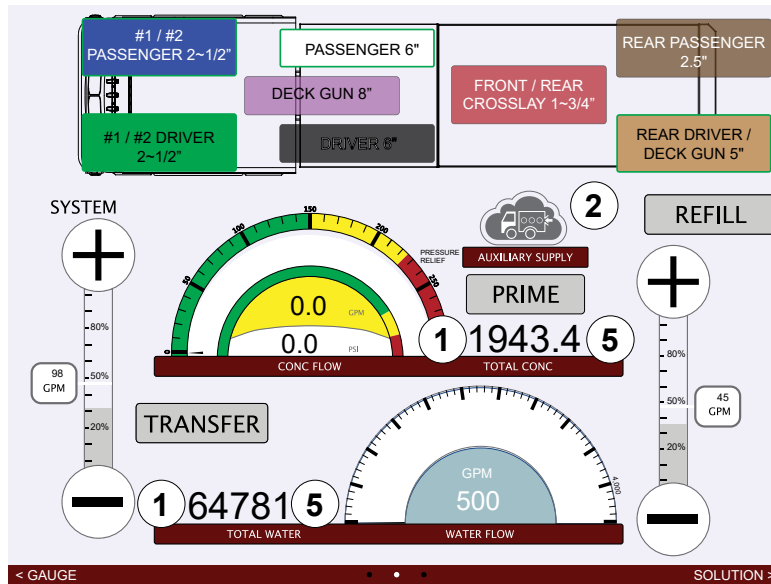

Use the illustrations and instructions to develop an after-operation flush procedure to remove residual concentrate in the plumbing.

Concentrate left in the plumbing after operation could degrade future performance. Therefore, it is recommended to completely flush any plumbing that may contain residual concentrate—including the DLA, prime, bypass, transfer, auxiliary, and drain lines—with clean water until all concentrate is removed from the plumbing.

- 1 Before flushing the plumbing, record the total concentrate and total water values. Otherwise, any values accrued during the flush procedure will be added to the totals, making them inaccurate.
- 2 Connect a clean water source to the auxiliary intake.
- 3 Set the prime bypass valve to divert water away from the concentrate supply tank.

**! Concentrate contamination:** Priming with water will lead to contamination if the priming line is plumbed to evacuate into the concentrate supply tank. To avoid contamination, install a bypass line to divert the water and drain any water in the concentrate line before priming the system.

- 4 Flush any plumbing exposed to concentrate and drain the lines to prevent future contamination.
- 5 Record the values after flushing the system, then press and hold the total concentrate and total water values to reset them to zero.

## Maintenance Schedule

---

No scheduled maintenance is required for the DLAs. However, it is recommended that you periodically inspect the system to reveal excess debris buildup, worn components, or any developing leaks. Consider environmental conditions, hours of operation, and other factors specific to your application to develop a suitable inspection schedule.

## Notes

**WATEROUS**

Waterous Company  
125 Hardman Avenue South  
South Saint Paul, MN 55075  
(651) 450-5000  
[www.waterousco.com](http://www.waterousco.com)