

# WATEROUS

Form Number: F-3050

Issue Date: Sep 17, 2024

## AQUIS™ ULTRAFLOW 160 Hydraulic and Foam Systems Installation and Operation

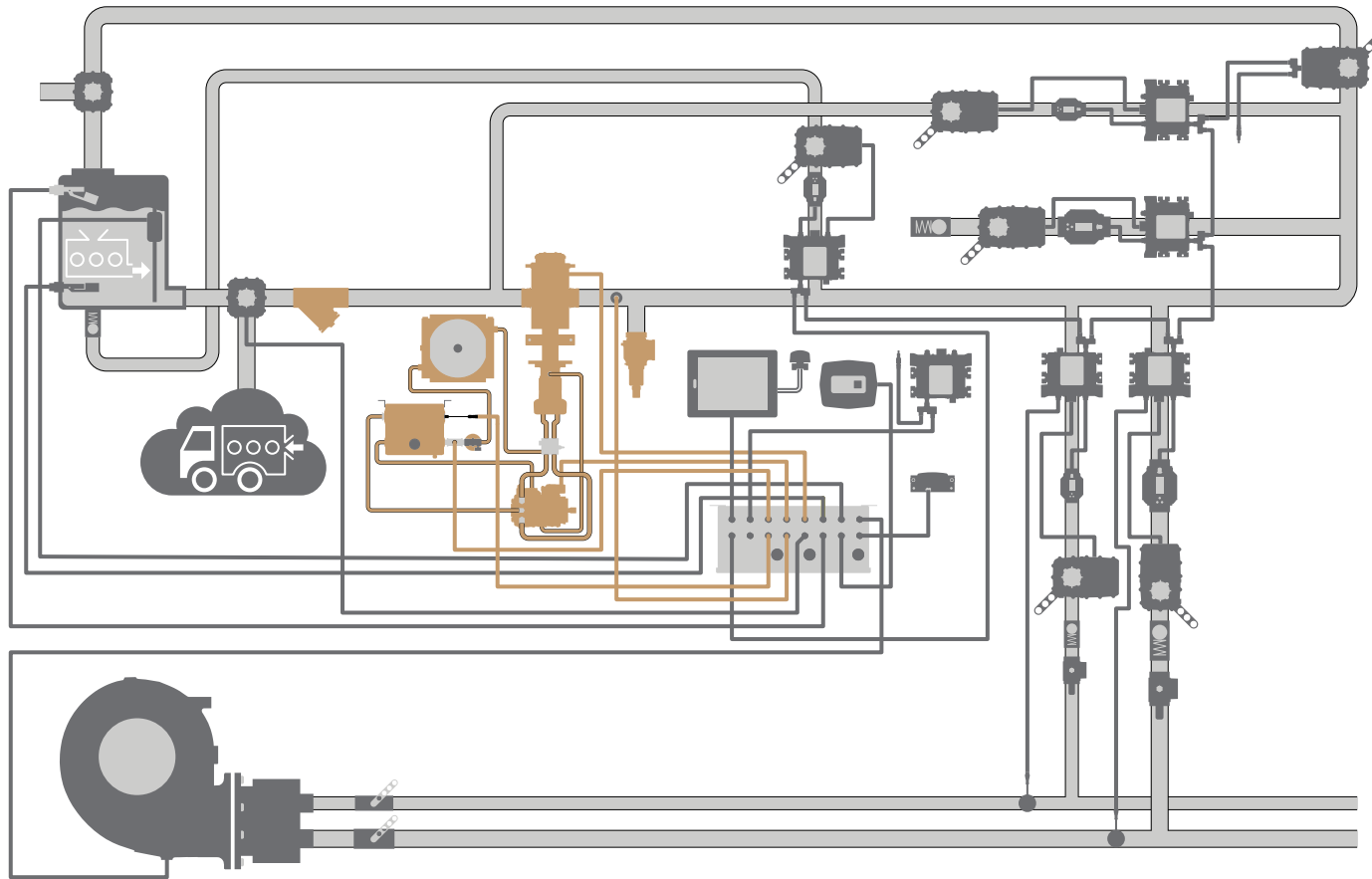

Waterous Company • 125 Hardman Avenue South • South Saint Paul, MN 55075 • (651) 450-5000

[www.waterousco.com](http://www.waterousco.com)



# Table of Contents

---

|   |           |   |           |
|---|-----------|---|-----------|
| <b>Safety</b>                                       | <b>4</b>  | Concentrate Supply Component Location                   | 52        |
| Safety Precautions                                  | 4         | Hydraulic Component Layout                              | 54        |
| <b>Introduction</b>                                 | <b>5</b>  | Installing the Hydraulic Hoses                          | 56        |
| Using this Document                                 | 5         | Installing the Temperature Switch                       | 58        |
| Viewing the Document Electronically                 | 5         | Installing the Hydraulic Motor and Concentrate Pump     | 59        |
| Printing the Document                               | 5         | Assembling the Hydraulic Reservoir                      | 60        |
| Additional Documentation                            | 5         | Installing the Concentrate Strainer                     | 61        |
| <b>Overview</b>                                     | <b>6</b>  | Installing the Pressure Relief Valve                    | 62        |
| Aquis UltraFlow Industrial Foam Proportioner System | 6         | Installing the Pressure Transducer                      | 63        |
| Hydraulic Components                                | 10        | Connecting the Hydraulic Pump to the Apparatus Drive    | 64        |
| Concentrate Pump Assembly                           | 12        | Connecting the Concentrate Pump and Pressure Transducer | 65        |
| Spider Coupler                                      | 14        | Connecting the Hydraulic Sensors and Hydraulic Pump     | 66        |
| Hydraulic Motor                                     | 16        | <b>Operation</b>  | <b>67</b> |
| Hydraulic Pump                                      | 18        | Operating the Hydraulic System                          | 67        |
| Hydraulic Heat Exchanger                            | 20        | <b>Maintenance</b>                                      | <b>68</b> |
| Loop Flush Manifold                                 | 22        | Maintenance Schedule                                    | 68        |
| Hydraulic Reservoir                                 | 24        |   |           |
| Hydraulic Level Sensor                              | 26        |   |           |
| Hydraulic Temperature Sensor                        | 28        |   |           |
| Hydraulic Temperature Switch                        | 30        |   |           |
| Hydraulic Suction Strainer                          | 32        |   |           |
| Hydraulic Filter Components                         | 34        |   |           |
| Concentrate Strainer                                | 36        |   |           |
| Pressure Relief Valve                               | 38        |   |           |
| Pressure Transducer                                 | 40        |   |           |
| 3.0 Meter Sensor Cable                              | 42        |   |           |
| 0.5 Meter Sensor Cable                              | 43        |   |           |
| Concentrate Pump Cable                              | 44        |   |           |
| Concentrate Pump Cable—Schematic                    | 45        |   |           |
| Hydraulic Pump Cable                                | 46        |   |           |
| Hydraulic Pump Cable—Schematic                      | 47        |   |           |
| <b>Installation</b>                                 | <b>49</b> |   |           |
| Installation Overview                               | 49        |   |           |
| Preparing for the Installation                      | 49        |   |           |
| Modifying the Equipment                             | 49        |   |           |
| Optional Equipment                                  | 49        |   |           |
| Determining Cable and Wire Routing                  | 49        |   |           |
| Plumbing Layout                                     | 50        |   |           |

## Safety Precautions

- Read and understand all the associated documentation before you begin operating the product.
- Contact Waterous when you have questions about operating or maintaining the equipment.
- Read and understand all the notices and safety precautions.
- Do not operate the equipment when safety guards are removed.
- Do not modify the equipment.

|  <b>WARNING</b>  |   |
|---|---|
| <p><b>High Pressure</b></p> <ul style="list-style-type: none"> <li>• Discharge ejected at high pressure can cause serious injury and damage.</li> <li>• Direct discharge away from people and equipment.</li> </ul> |  |

| <b>NOTICE</b>  |   |
|--|---|
| <p><b>Modification</b></p> <ul style="list-style-type: none"> <li>• Modifying the equipment can damage components and void your warranty.</li> <li>• Do not modify the system or any of its components.</li> </ul> |  |

| <b>NOTICE</b>   |   |
|---|---|
| <p><b>Before Operation</b></p> <ul style="list-style-type: none"> <li>• Read and understand all the instructions provided.</li> <li>• Check all fluid levels and replenish if necessary.</li> <li>• Remove all shipping plugs and install the operation plugs or caps.</li> </ul> |  |

 Read and understand all warnings following this symbol.

Use this document to install and operate your Waterous equipment. Understand the following conditions before proceeding:

- The instructions may refer to options or equipment that you may not have purchased with your system.
- The illustrations in this document are intended to convey concepts. Do not use the illustrations to determine physical attributes, placement, or proportion.
- Understand that your application may require additional steps, that are not described in the illustrations or instructions, to perform the installation.
- The equipment described in this document is intended to be installed by a person or persons with the necessary skills and knowledge to perform the installation.
- The equipment described in this document is intended to be operated by a person or persons with the basic knowledge of operating similar equipment.
- The information in this document is subject to change without notice.

This document is divided into the following sections:

#### SAFETY

This section describes general precautions and alert symbols in the document.

#### INTRODUCTION

This section is an overview of the document.

#### OVERVIEW

This section describes the components that make up the system.

#### INSTALLATION

This section describes the installation and initial setup procedures.

#### OPERATION

This section describes the equipment operation.

#### MAINTENANCE

This section describes any required maintenance.

## Using this Document

---

Use the guidelines below when viewing this document.

### Viewing the Document Electronically

---

- View this document in landscape orientation.
- Use the table of contents to navigate directly to that section.
- Text **with this appearance** is linked to a reference.

### Printing the Document

---

- The document is designed to be printed on both sides and in color.
- Use a 3-ring binder to store the document.

## Additional Documentation

---

Additional documentation is available through the MyWaterous login at [waterousco.com](http://waterousco.com). Use your serial number to gain access to the service parts list associated with your system. Dimensional drawings are available through the Waterous Service department.

## Aquis UltraFlow Industrial Foam Proportioner System

*Note: Make sure that the installer-supplied UltraFlow plumbing cannot trap fluid and allows fluid to be drained from the system when required.*

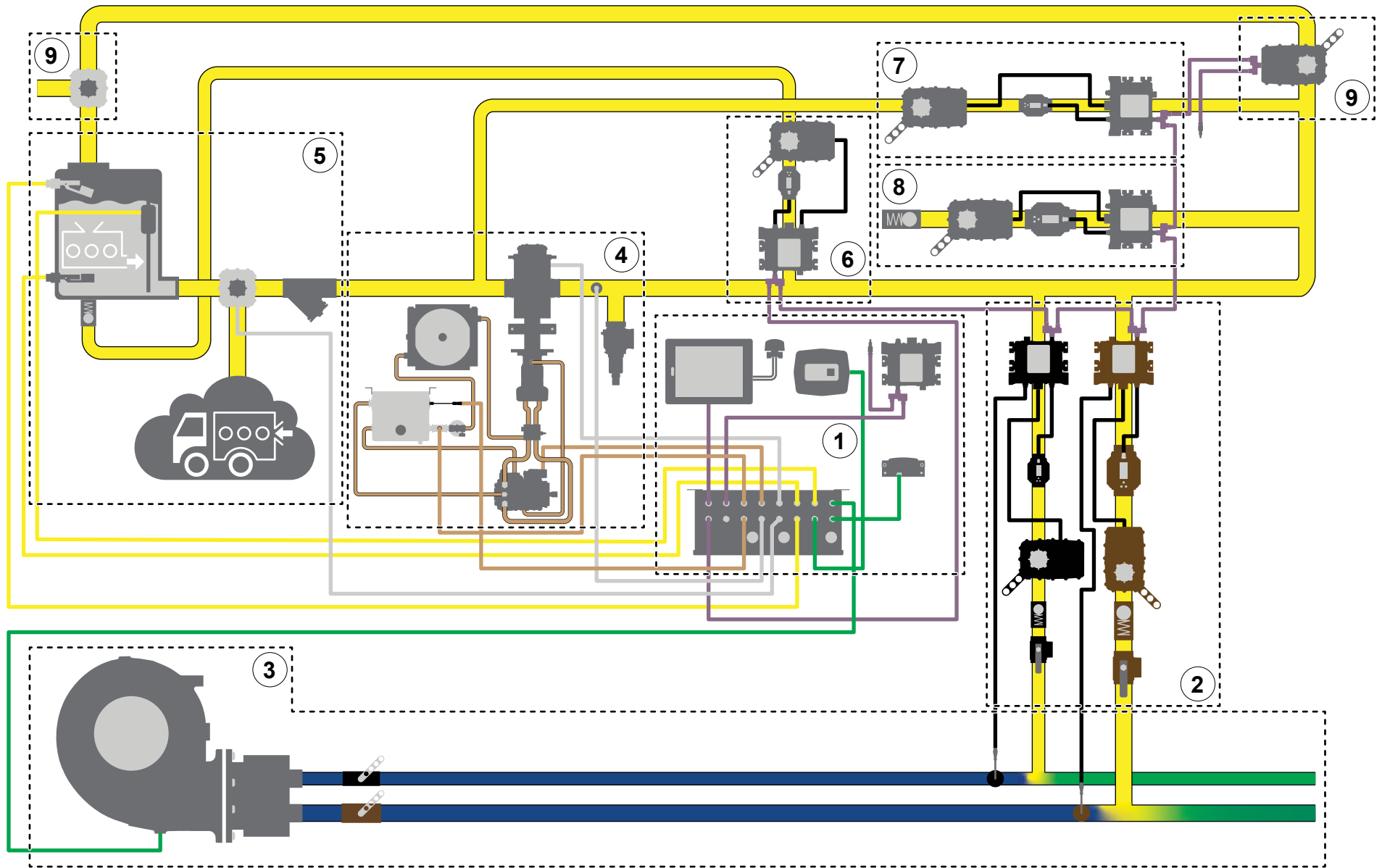

## Aquis UltraFlow Industrial Foam Proportioner System

The Aquis UltraFlow industrial foam proportioner system supplies concentrate into a solution-capable discharge line. A Tellurus™ control panel, or human machine interface (HMI), shows system activity and provides control of the system using a CANbus protocol. Foam concentrate is sourced from an on-board supply tank or an auxiliary source. The concentrate pump distributes concentrate through the discharge line assembly (DLA) using hydraulic components. The concentrate is then measured, controlled, and introduced into the solution-capable discharge line to produce foam solution. Understand that your application will include all or portions of the components described.

| Subsystem                    | Description   |
|------------------------------|---|
| 1 Control system             | <p>This monitors and controls the foam proportioner system. The components in this subsystem include:</p> <ul style="list-style-type: none"> <li>• Control panel—this displays system operation and provides control of the system.</li> <li>• Control box—this connects to various system components and contains the programmable logic controllers (PLCs).</li> <li>• Manual override panel—this disables the automatic control of the concentrate control valves.</li> <li>• Power relay panel—this enables and disables power to the DLA.</li> <li>• Remote I/O—this adds a node controller to the system for additional options required in your application.</li> <li>• Various cables—these provide communication and power to system components.</li> </ul>  |
| 2 Discharge line assembly    | <p>This manages the concentrate injected into the solution-capable discharge. The system can control up to 19 DLAs. The components in this subsystem include:</p> <ul style="list-style-type: none"> <li>• Node controller—this connects to and controls the concentrate control valve, and reads the flowmeters and discharge pressure transducer.</li> <li>• CAN cable splitter—this connects the node controllers to one another and the control box.</li> <li>• DLA terminating resistor—this terminates the CAN connection on the last node controller or valve in the CAN chain.</li> <li>• Concentrate control valve—this controls the concentrate flow.</li> <li>• Magnetic flowmeter—this measures the concentrate flow.</li> <li>• Check valve—this prevents contamination of concentrate by preventing reverse fluid flow in the line.</li> <li>• Cal/Inject valve—this allows you to divert and collect water or concentrate when calibrating the your system.</li> </ul> |
| 3 Solution-capable discharge | <p>This includes the installer-supplied water pump, distribution manifold, plumbing, and additional components that produce water flow. Additional components in this subsystem include:</p> <ul style="list-style-type: none"> <li>• Paddlewheel flowmeter—this measures the water flow in the discharge.</li> </ul> <p><b>Note:</b> You can install the flowmeter upstream or downstream of where the concentrate is injected into the waterway.</p> <ul style="list-style-type: none"> <li>• Water discharge pressure transducer—this measures the pressure at the pump discharge.</li> </ul> <p><b>Note:</b> Some applications do not allow for the discharge pressure to be measured at the pump, in those applications alternative measurement methods are used.</p> <ul style="list-style-type: none"> <li>• Solution discharge pressure transducer—this measures the pressure at the solution-capable discharge.</li> </ul>   |

## Aquis UltraFlow Industrial Foam Proportioner System

| Subsystem                        | Description  |
|----------------------------------|--|
| 4 Concentrate pump               | <p>These components support, control, and power the concentrate pump. The components in this subsystem include:</p> <ul style="list-style-type: none"> <li>• Concentrate pump—this circulates the foam concentrate through the system.</li> <li>• Hydraulic motor—this drives the concentrate pump.</li> <li>• Hydraulic pump—this drives the hydraulic motor.</li> <li>• Hydraulic reservoir—this contains the hydraulic fluid supply.</li> <li>• Hydraulic filter—this filters the hydraulic fluid.</li> <li>• Hydraulic heat exchanger—this cools the hydraulic fluid.</li> <li>• Hydraulic temperature sensor—this measures the hydraulic fluid temperature.</li> <li>• Hydraulic temperature switch—this activates the fan control circuit.</li> <li>• Hydraulic level sensor—this monitors the hydraulic fluid level in the reservoir.</li> <li>• Loop flush manifold—this draws hot hydraulic fluid from the main hydraulic lines and sends it to the heat exchanger.</li> <li>• Concentrate discharge pressure transducer—this measures the pressure in the concentrate line.</li> <li>• Pressure relief valve—this limits the pressure in the concentrate discharge manifold by opening when the pressure reaches a predetermined level.</li> </ul> |
| 5 Concentrate supply             | <p>This contains components that hold or supply foam concentrate for the system. The components in this subsystem include:</p> <ul style="list-style-type: none"> <li>• Concentrate supply tank—this contains the on-board foam concentrate supply.</li> <li>• Tank-full sensor—this indicates a tank full condition to the system.</li> <li>• Tank-low sensor—this indicates a tank low condition to the system.</li> <li>• Tank level sensor—this is an installer-supplied sensor and display that indicates the supply level in the tank.</li> <li>• Concentrate pump intake select valve—this is an installer-supplied, 2-position valve and additional components that source concentrate from an on-board tank or an auxiliary supply. A signal is provided to the system to ignore the on-board tank sensors when sourcing concentrate from an auxiliary supply.</li> <li>• Concentrate strainer—this collects debris that would otherwise flow through the system and potentially damage the concentrate pump.</li> </ul>  |
| 6 Concentrate supply refill line | <p>This allows you to fill the on-board tank from an external source. The components in this subsystem include:</p> <ul style="list-style-type: none"> <li>• Node controller—this connects to the fill valve and flowmeters.</li> <li>• Fill line control valve—this controls the concentrate flow.</li> <li>• Magnetic flowmeter—this measures the concentrate flow.</li> <li>• CAN cable splitter—this connects the node controllers to one another and the control box.</li> <li>• Check valve—this prevents reverse fluid flow in the line.</li> </ul>   |



## Aquis UltraFlow Industrial Foam Proportioner System

| Subsystem              | Description  |
|------------------------|--|
| 7 Low-flow bypass line | <p>This returns a portion of the concentrate in the supply line back to the pump inlet when the desired concentrate output requires the pump to operate at an rpm that is lower than its capabilities. The components in this subsystem include:</p> <ul style="list-style-type: none"> <li>• Node controller—this connects to the low-flow control valve and flowmeters.</li> <li>• Low-flow valve—this controls the concentrate return flow.</li> <li>• Magnetic flowmeter—this measures the concentrate flow.</li> <li>• CAN cable splitter—this connects the node controllers to one another.</li> </ul>   |
| 8 Transfer line        | <p>This allows you to transfer or relay concentrate from the apparatus to another location. The components in this subsystem include:</p> <ul style="list-style-type: none"> <li>• Node controller—this connects to and controls the concentrate control valve and flowmeters.</li> <li>• CAN cable splitter—this connects the node controllers to one another and the control box.</li> <li>• Concentrate control valve—this controls the concentrate flow.</li> <li>• Magnetic flowmeter—this measures the concentrate flow.</li> <li>• Check valve—this prevents reverse fluid flow in the line.</li> </ul>   |
| 9 Priming line         | <p>This evacuates air from the concentrate pump inlet as the system primes before operation. The components in this subsystem include:</p> <ul style="list-style-type: none"> <li>• Priming valve—this opens to allow air to evacuate the line before operation.</li> <li>• CAN cable splitter—this connects the node controllers to one another and the control box.</li> <li>• Prime bypass valve—this is an installer-supplied valve that prevents contaminating the concentrate during training. When water is substituted for concentrate during training or testing, and there is concentrate in the supply tank, this bypass valve prevents water from contaminating the concentrate supply.</li> </ul> <p><b>Note:</b> You must drain any remaining water in the line before priming the system with concentrate to prevent contamination.</p> |

## Hydraulic Components

The hydraulic system powers the foam concentrate pump. Apparatus power circulates hydraulic fluid from the reservoir, through the hydraulic motor in order to power the concentrate pump, through the heat exchanger and filter, then back to the reservoir.

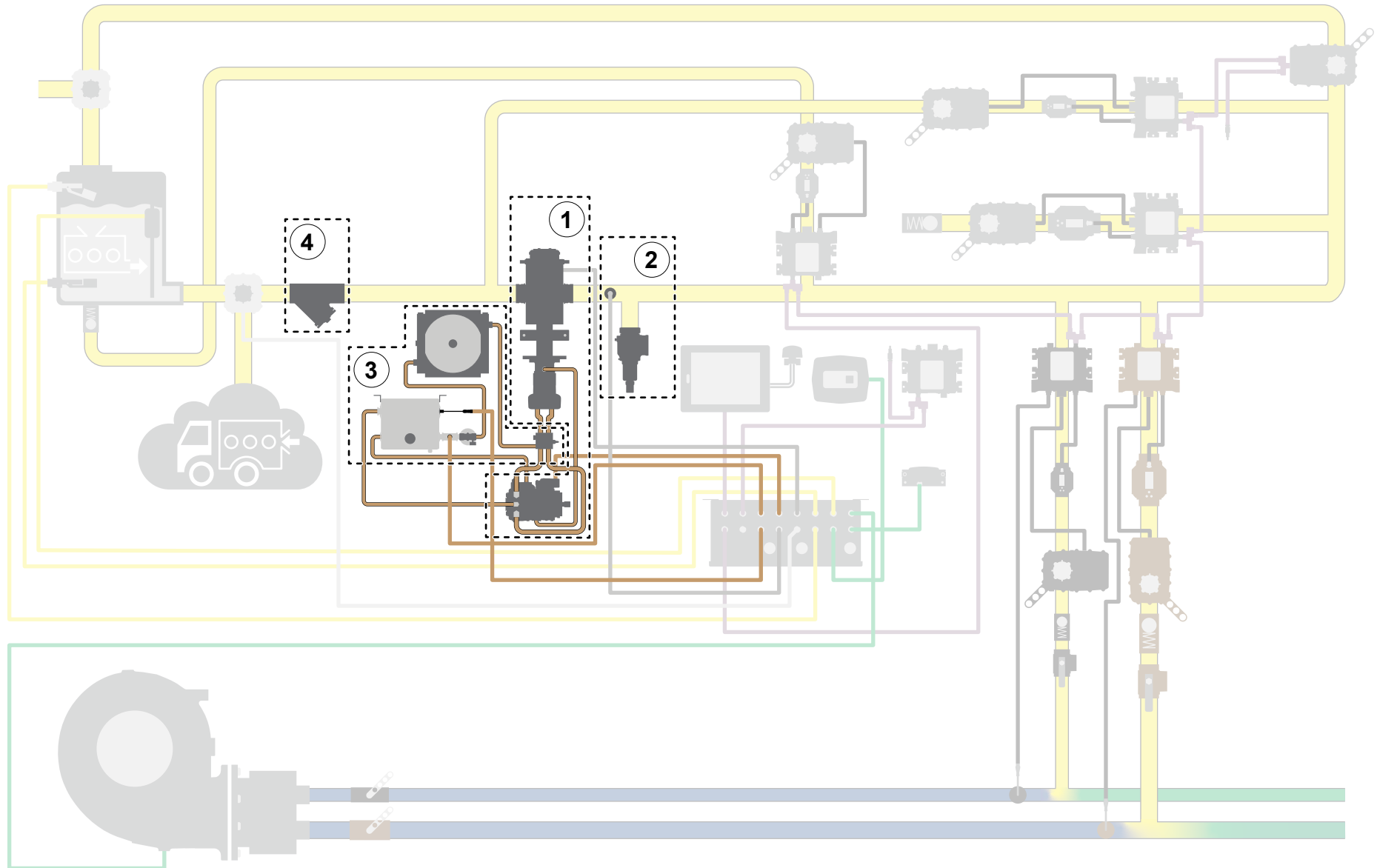

## Hydraulic Components

---

| Subsystem                     | Description  |
|-------------------------------|--|
| 1 Concentrate pump components | This transports the concentrate through the system. It includes the concentrate pump, hydraulic motor, and hydraulic pump.                               |
| 2 Pressure components         | This measures and manages the pressure in the concentrate line. It includes the pressure transducer and pressure relief valve.                           |
| 3 Hydraulic fluid components  | This contains and manages the hydraulic fluid. It includes the hydraulic reservoir, hydraulic filter, hydraulic heat exchanger, and loop flush manifold. |
| 4 Concentrate strainer        | This collects debris that would otherwise flow through the system and potentially damage the concentrate pump.   |

## Concentrate Pump Assembly

The concentrate pump assembly includes the concentrate pump and a flange to mount the hydraulic motor.

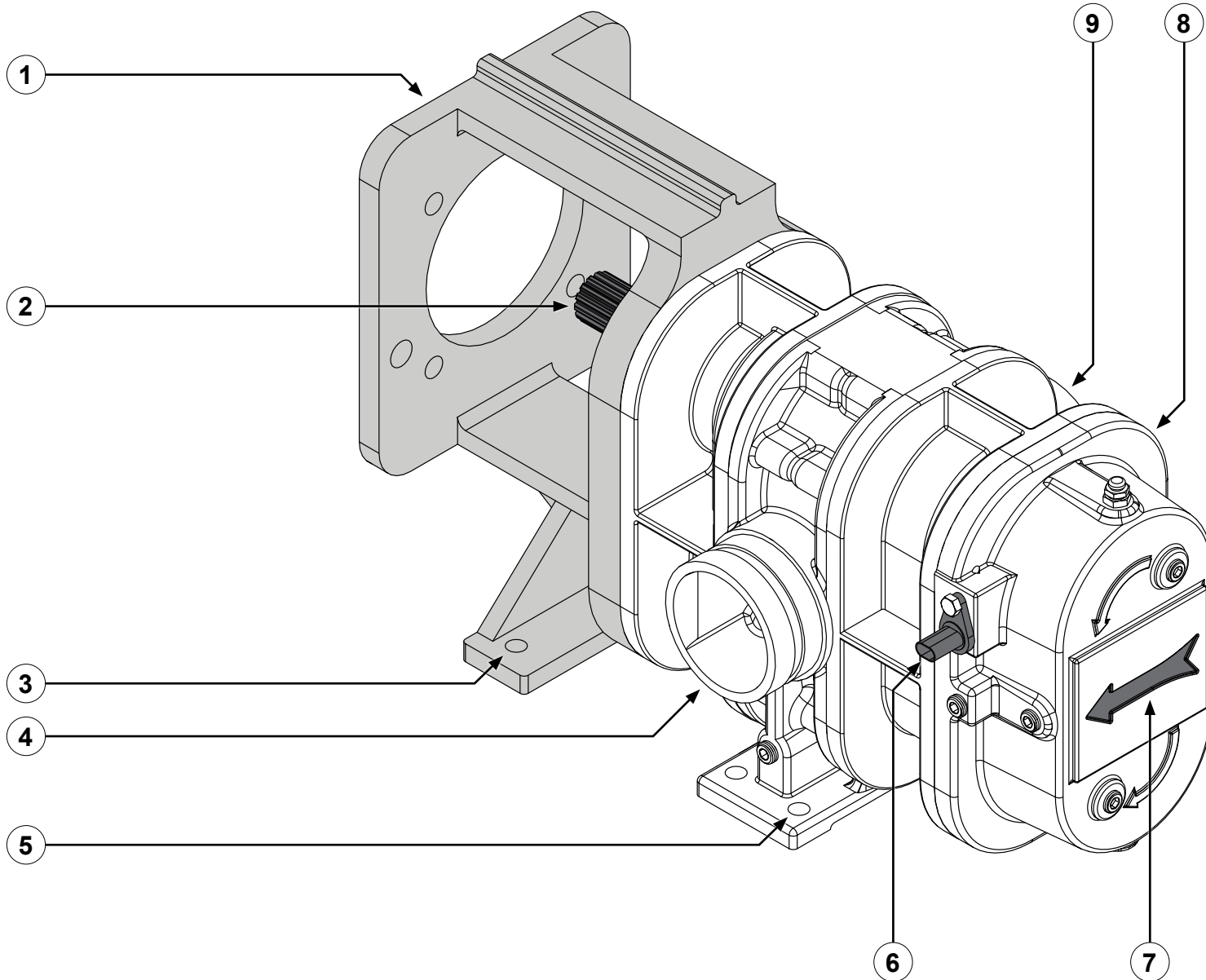

## Concentrate Pump Assembly

---

| Feature                           | Description   |
|-----------------------------------|---|
| 1 Motor mount flange              | This allows the hydraulic motor to be mounted on the concentrate pump.          |
| 2 Drive shaft                     | This drives the concentrate pump—14T 12/24 spline.                              |
| 3 Flange mounting holes           | These mount the motor mount flange on the apparatus.                            |
| 4 Concentrate outlet              | This is where the concentrate exits the pump—3-inch Victaulic®.                 |
| 5 Concentrate pump mounting holes | These mount the pump on the apparatus.  |
| 6 Speed sensor connector          | This connects to the concentrate pump cable, which connects to the control box. |
| 7 Flow indicator                  | This indicates the direction of flow.   |
| 8 Concentrate pump                | This pressurizes the concentrate in the concentrate discharge manifold.         |
| 9 Concentrate inlet               | This is where the concentrate enters the pump—3-inch Victaulic.                 |

## Spider Coupler

The coupler connects the concentrate pump shaft to the hydraulic motor shaft.

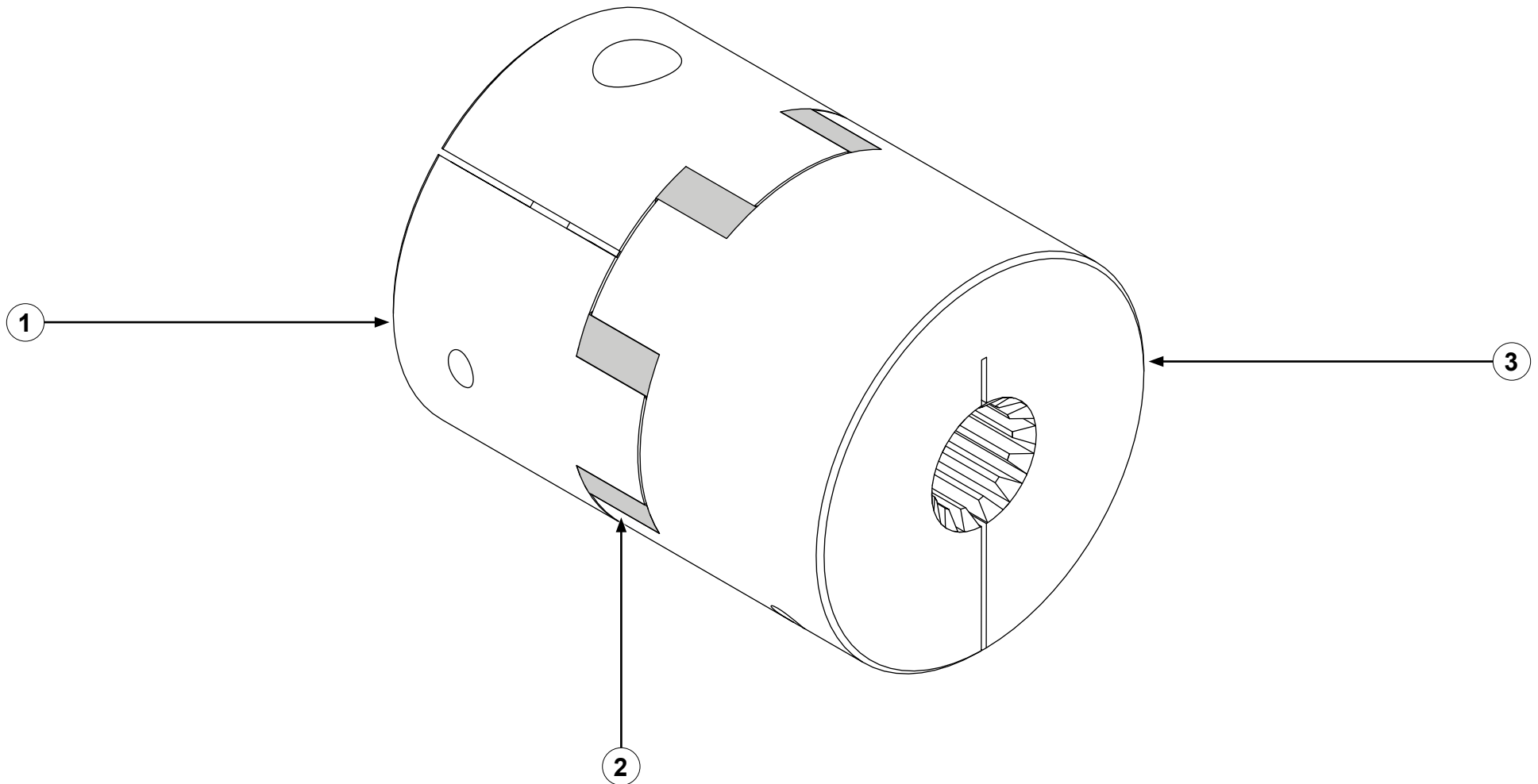

## Spider Coupler

---

| Feature            | Description   |
|--------------------|---|
| 1 Motor hub        | This connects to the hydraulic motor.<br><b>Note:</b> <i>The motor hub and pump hub are interchangeable.</i>  |
| 2 Elastomer spider | This transfers torque between the hubs.   |
| 3 Pump hub         | This connects to the concentrate pump.<br><b>Note:</b> <i>The pump hub and motor hub are interchangeable.</i> |

## Hydraulic Motor

The hydraulic motor is controlled by the hydraulic pump and drives the concentrate pump.

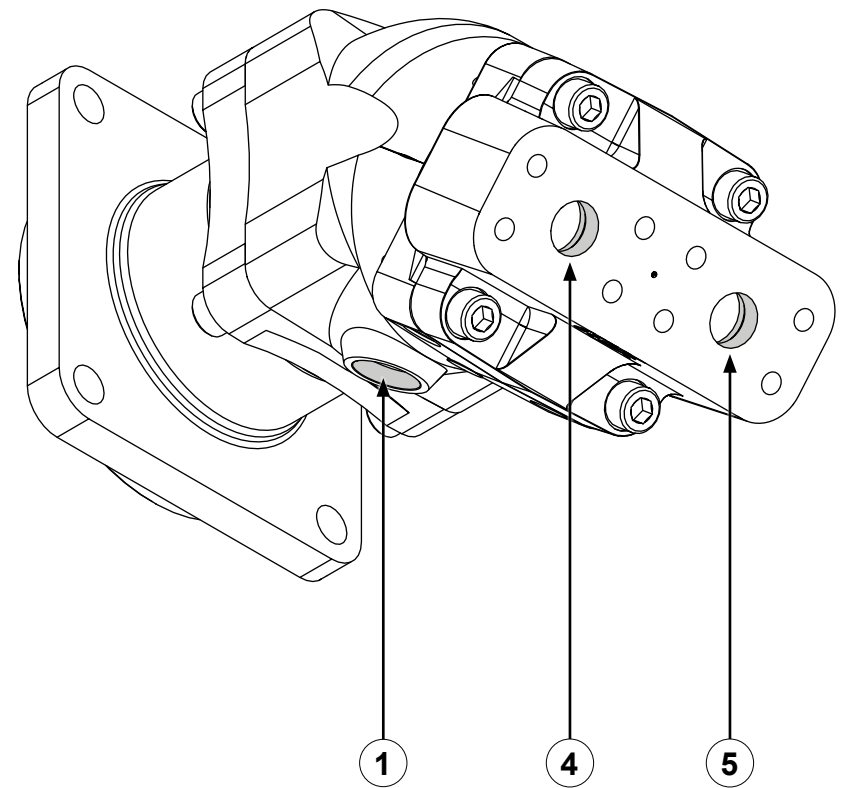
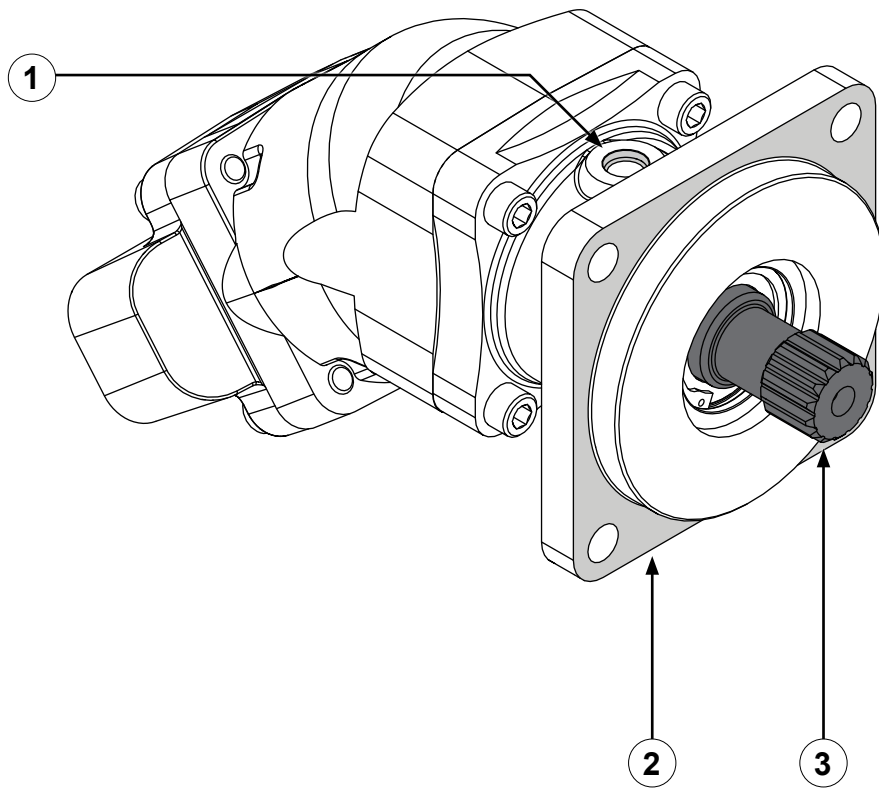



## Hydraulic Motor

| Feature                 | Description  |
|-------------------------|--|
| 1 Fill and drain ports  | The fill and drain ports are interchangeable. The upper port connects to the hydraulic pump and the lower port serves as a drain—#6 (9/16-18 UNF-2B) SAE 1926-1. |
| 2 Mounting flange       | This allows the motor to be mounted on the concentrate pump motor mount flange.  |
| 3 Hydraulic motor shaft | This connects to the concentrate pump—14T 12/24 spline.  |
| 4 A-port                | This connects to the A1-port on the loop flush manifold—SAE J518 (Code 62), 1-inch, 4-bolt split flange.   |
| 5 B-port                | This connects to the B1-port on the loop flush manifold—SAE J518 (Code 62), 1-inch, 4-bolt split flange.   |

# Hydraulic Pump

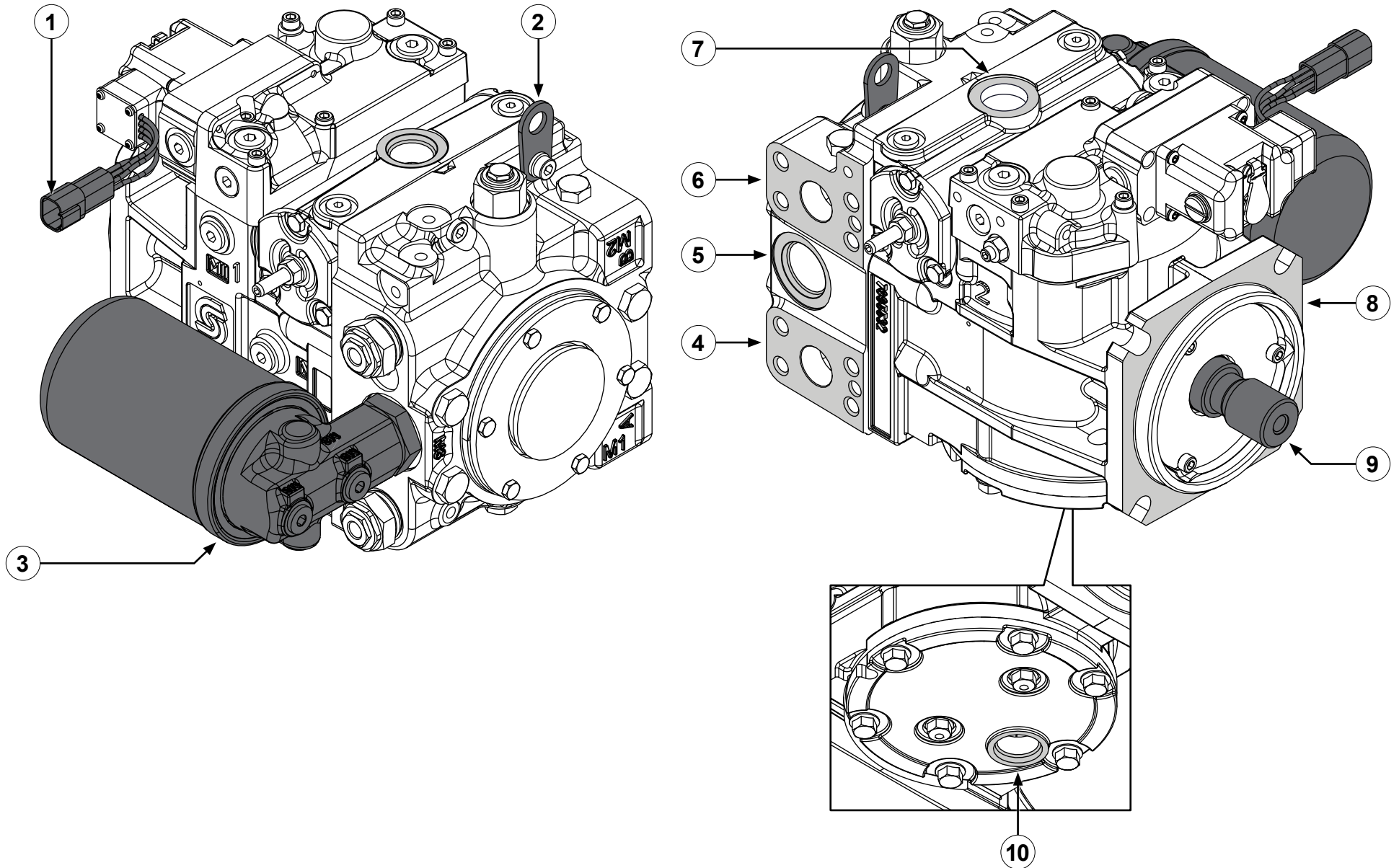

## Hydraulic Pump

| Feature                | Description   |
|------------------------|---|
| 1 Swashplate connector | This connects to the hydraulic pump cable, which connects to the control box.   |
| 2 Lift point           | This assists in lifting the pump.   |
| 3 Hydraulic filter     | This filters the hydraulic fluid.   |
| 4 A-port outlet        | This connects to the A2-port on the loop flush manifold—SAE J518 (Code 62), 1-inch, 4-bolt split flange.                |
| 5 S-port inlet         | This supplies hydraulic fluid from the reservoir—#16 (1-5/16-12 UN-2B) SAE J1926-1.                                     |
| 6 B-port outlet        | This connects to the B2-port on the loop flush manifold—SAE J518 (Code 62), 1-inch, 4-bolt split flange.                |
| 7 L1 case drain port   | This returns hydraulic fluid that is providing internal lubrication to the reservoir—#12 (1-1/16-12 UN-2B) SAE J1926-1. |
| 8 Pump mount           | This allows the hydraulic pump to be mounted on the apparatus.  |
| 9 Input shaft          | This connects to the apparatus and drives the hydraulic pump—13T 8/16 spline.   |
| 10 L2 case drain port  | This returns hydraulic fluid from the motor casing to the reservoir—#12 (1-1/16-12 UN-2B) SAE J1926-1.                  |

## Hydraulic Heat Exchanger

The hydraulic heat exchanger manages the hydraulic fluid temperature.

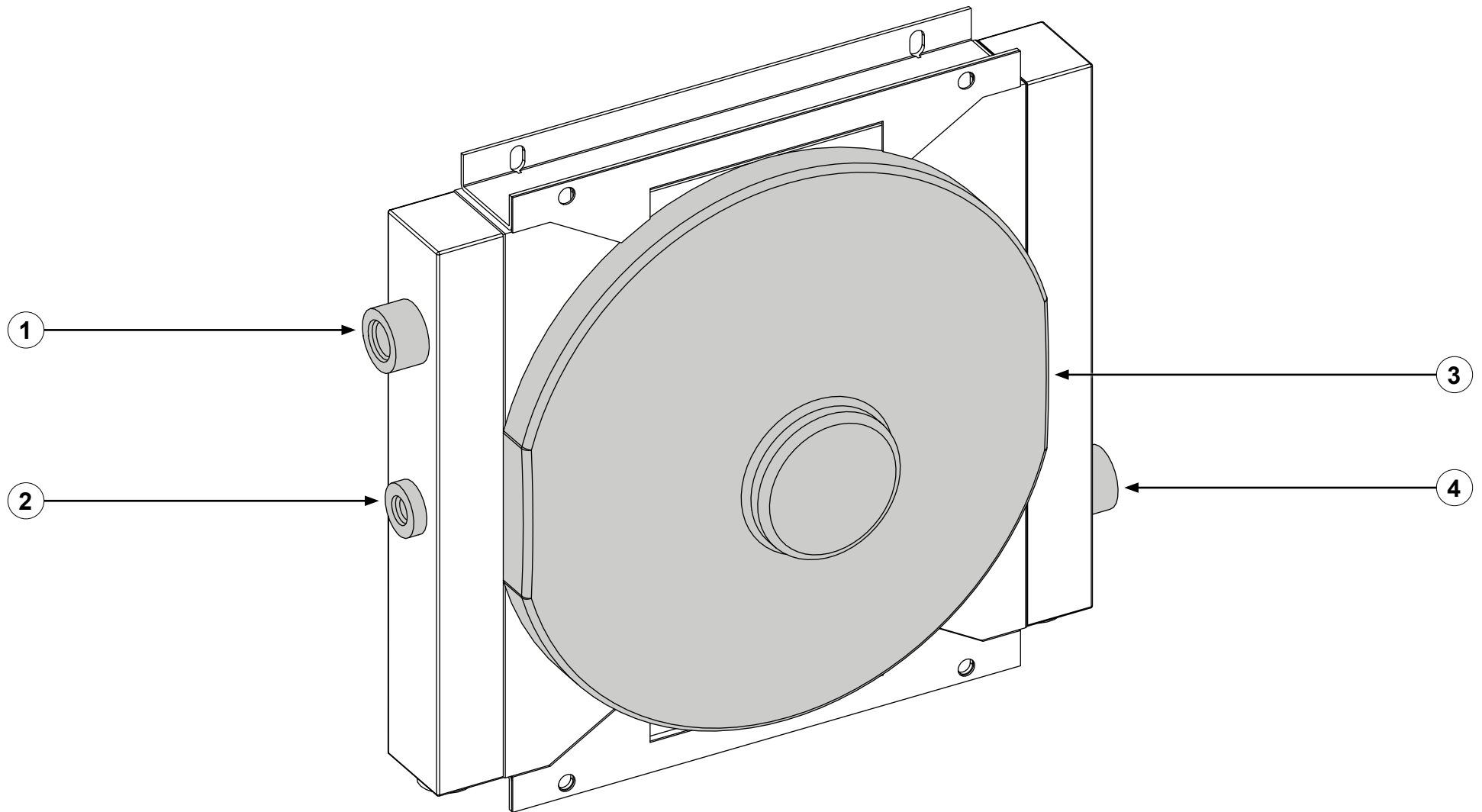

## Hydraulic Heat Exchanger

---

| Feature                   | Description  |
|---------------------------|--|
| 1 Hydraulic inlet         | This is where the hydraulic fluid enters the heat exchanger—#16 (1-5/16-12 UN-2B) SAE J1926-1. |
| 2 Temperature switch port | This is the port for the temperature switch—#8 (3/4-16 UNF-2B) SAE J1926-1.                    |
| 3 Fan and motor           | This cools the hydraulic fluid.  |
| 4 Hydraulic outlet        | This is where the hydraulic fluid exits the heat exchanger—#16 (1-5/16-12 UN-2B) SAE J1926-1.  |

## Loop Flush Manifold

The loop flush manifold draws hot hydraulic fluid from the main hydraulic lines and sends it to the heat exchanger.

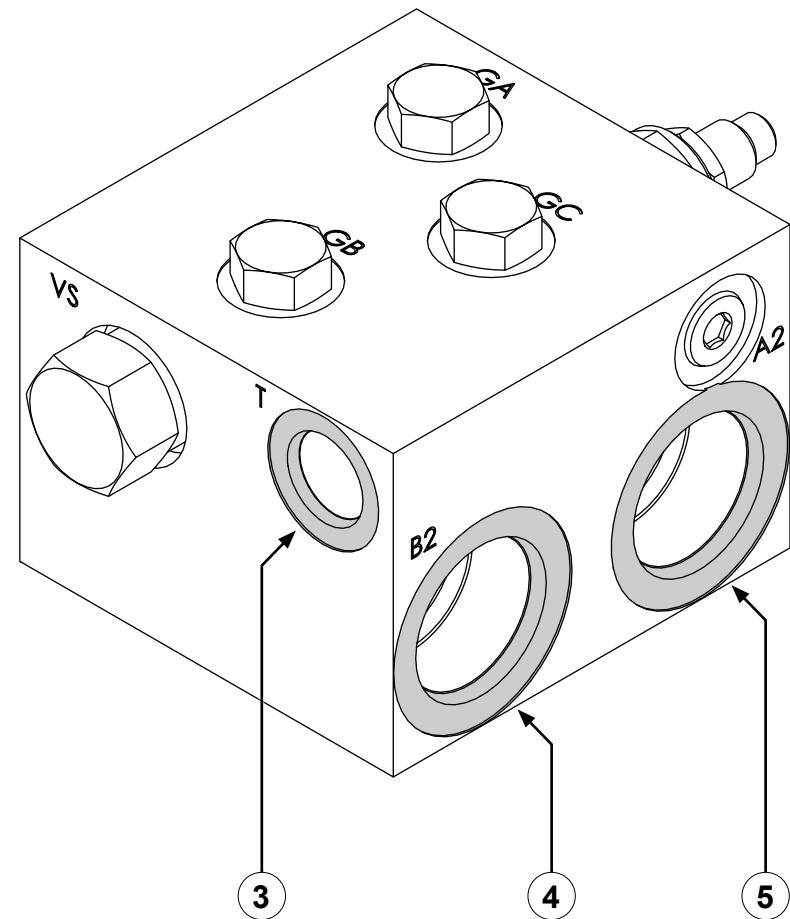
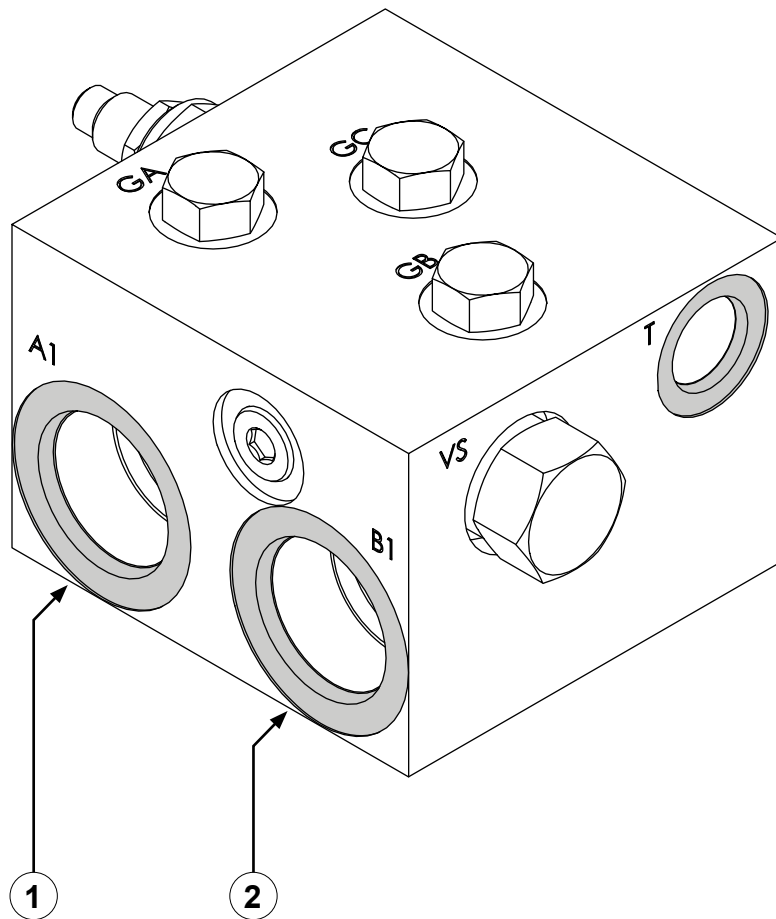

## Loop Flush Manifold

---

| Feature   | Description   |
|-----------|---|
| 1 A1-port | This connects to the A-port on the hydraulic motor—#16 (1-5/16-12 UN-2B) SAE J1926-1. |
| 2 B1-port | This connects to the B-port on the hydraulic motor—#16 (1-5/16-12 UN-2B) SAE J1926-1. |
| 3 T-port  | This connects to the bypass—#8 (3/4-16 UNF-2B) SAE J1926-1.                           |
| 4 A2-port | This connects to the A-port on the hydraulic pump—#16 (1-5/16-12 UN-2B) SAE J1926-1.  |
| 5 B2-port | This connects to the B-port on the hydraulic pump—#16 (1-5/16-12 UN-2B) SAE J1926-1.  |

## Hydraulic Reservoir

The reservoir holds the hydraulic fluid supply. The ports on the reservoir are mirrored and interchangeable to suit your application.

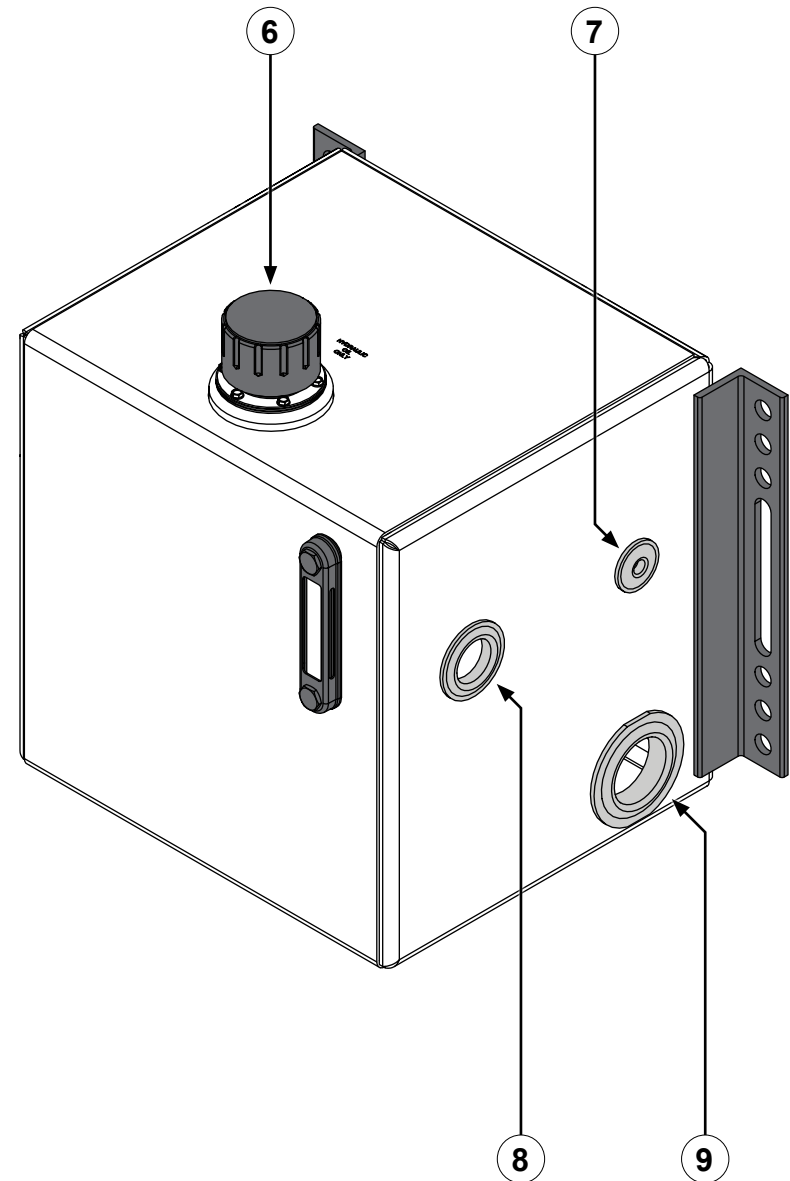
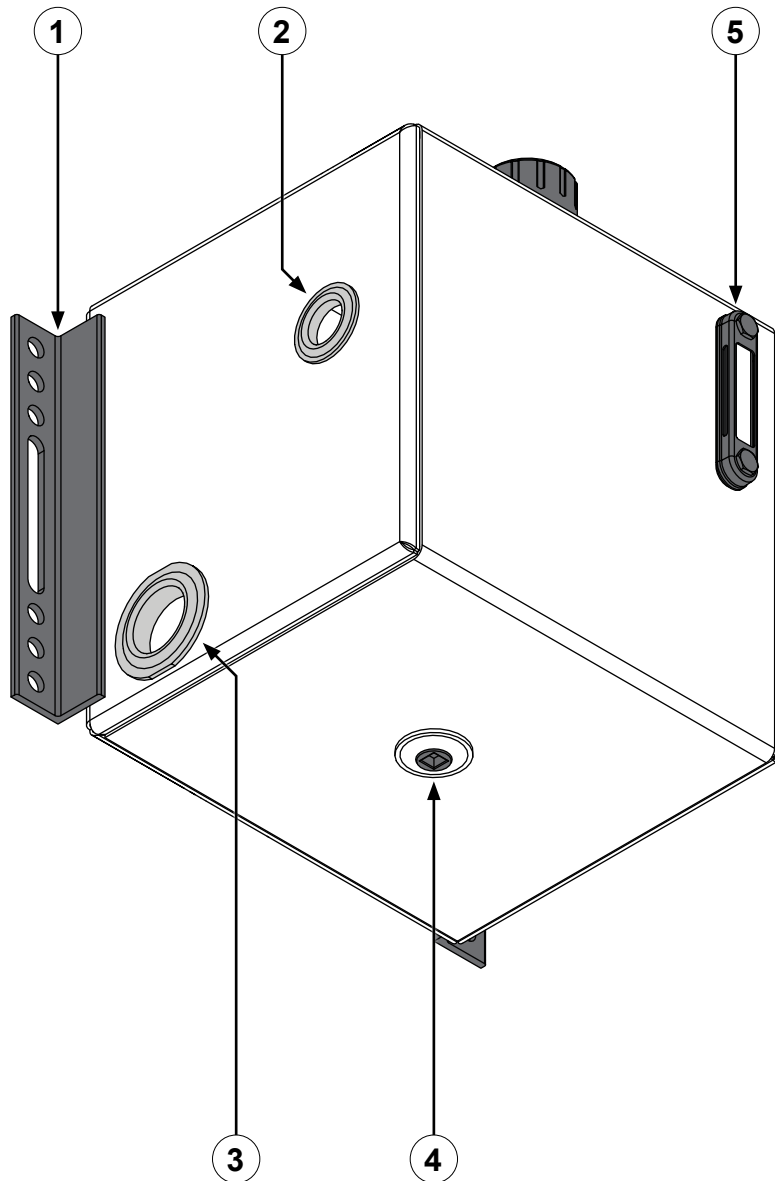



## Hydraulic Reservoir

---

| Feature                 | Description  |
|-------------------------|--|
| 1 Mounting brackets     | These mount the hydraulic reservoir on the apparatus.<br><b>Note:</b> <i>Mount the reservoir above the hydraulic pump and hydraulic motor.</i> |
| 2 Left side upper port  | This port connects to the hydraulic pump in typical applications—1-1/4 NPT.  |
| 3 Left side lower port  | This connects to the hydraulic pump in typical applications—2 NPT. A strainer is installed directly into the port.                             |
| 4 Magnetic drain port   | This is where hydraulic fluid is drained from the reservoir—3/4 NPT. It contains a magnet to collect metal fragments.                          |
| 5 Sight gauge           | This shows the hydraulic fluid level in the reservoir.   |
| 6 Fill port             | This is where hydraulic fluid is added to the reservoir.   |
| 7 Accessory port        | This is where the level sensor is installed into the reservoir—1/4 NPT.  |
| 8 Right side upper port | This port connects to the filter and temperature sensor in typical applications—1-1/4 NPT.   |
| 9 Right side lower port | This remains plugged in typical applications—2 NPT.  |

## Hydraulic Level Sensor

The level sensor monitors the hydraulic fluid level in the reservoir.

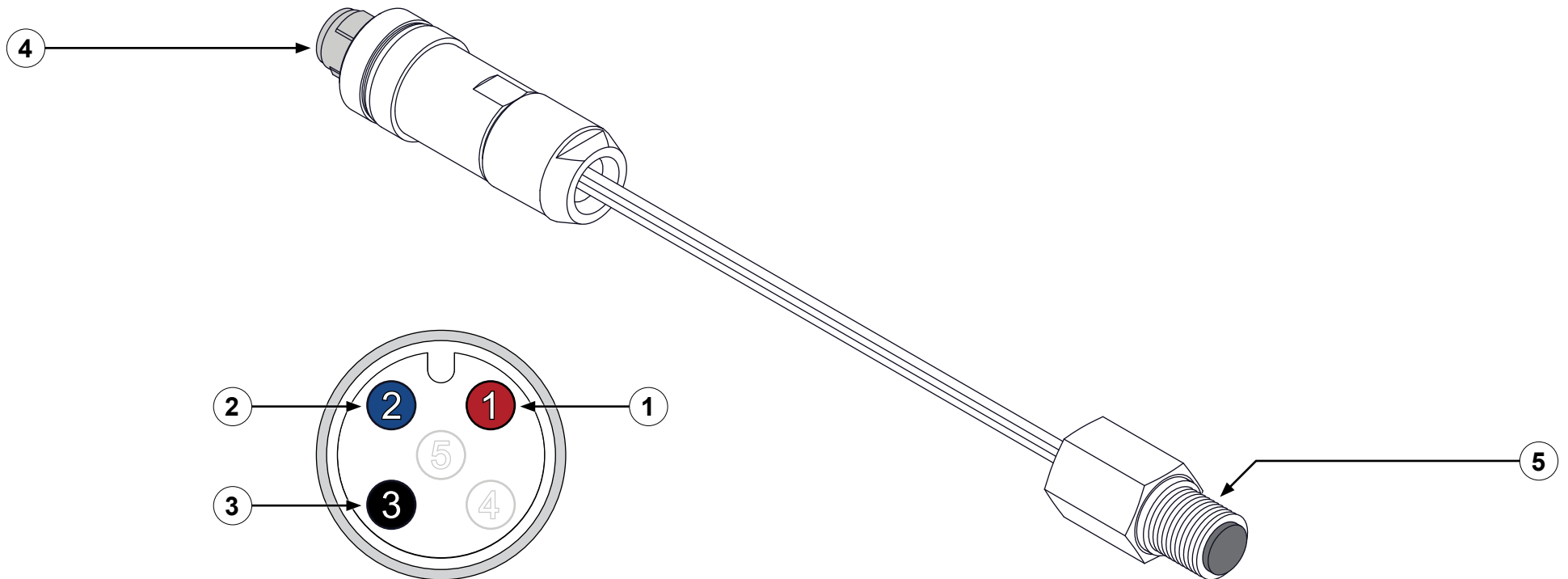

## Hydraulic Level Sensor

---

|   | Feature        | Description  |
|---|----------------|--|
| 1 | Red wire       | Vcc, +12 V   |
| 2 | Blue wire      | Signal   |
| 3 | Black wire     | Ground   |
| 4 | M12 connector  | This connects to the control box through a sensor cable. |
| 5 | Optical sensor | This monitors the hydraulic fluid level—1/4 NPT.         |

## Hydraulic Temperature Sensor

The temperature sensor measures the hydraulic fluid temperature in the reservoir.

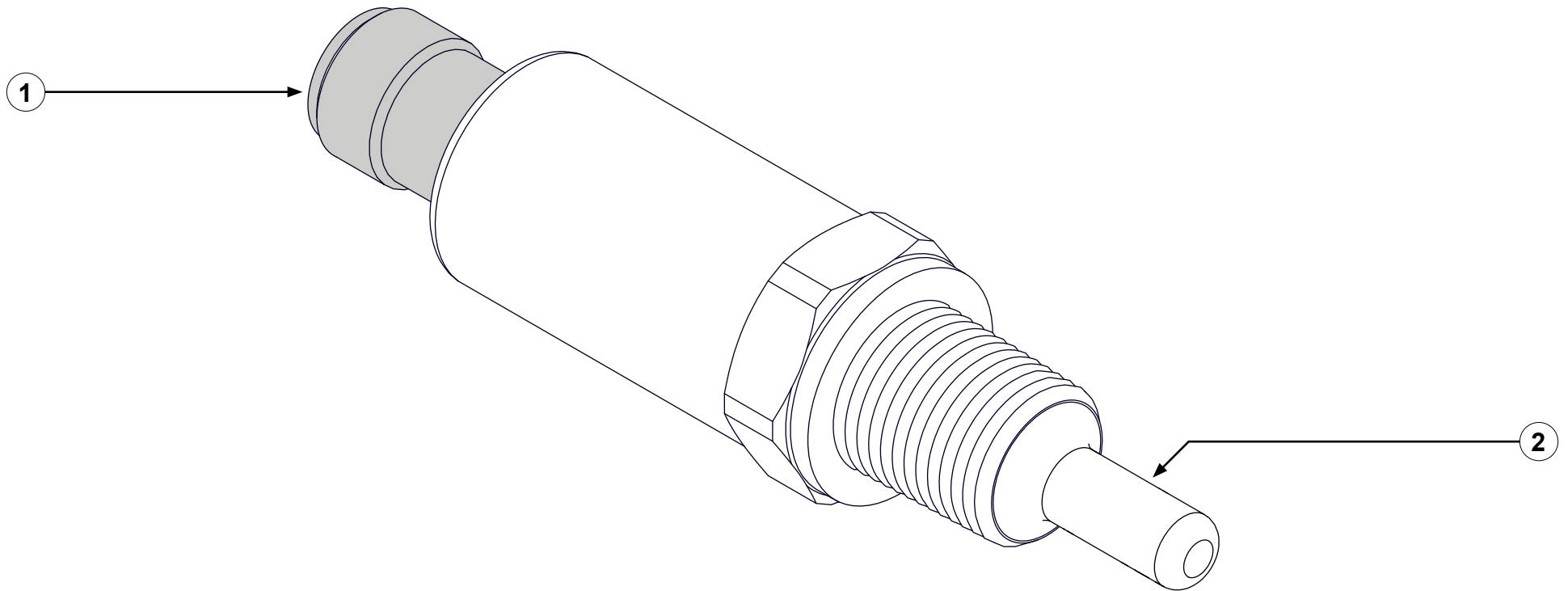

## Hydraulic Temperature Sensor

---

| Feature             | Description  |
|---------------------|--|
| 1 M12 connector     | This connects to the control box through a sensor cable. |
| 2 Temperature probe | This measures the hydraulic fluid temperature—1/4 NPT.   |

## Hydraulic Temperature Switch

The temperature switch operates the circuit that controls the heat exchanger.

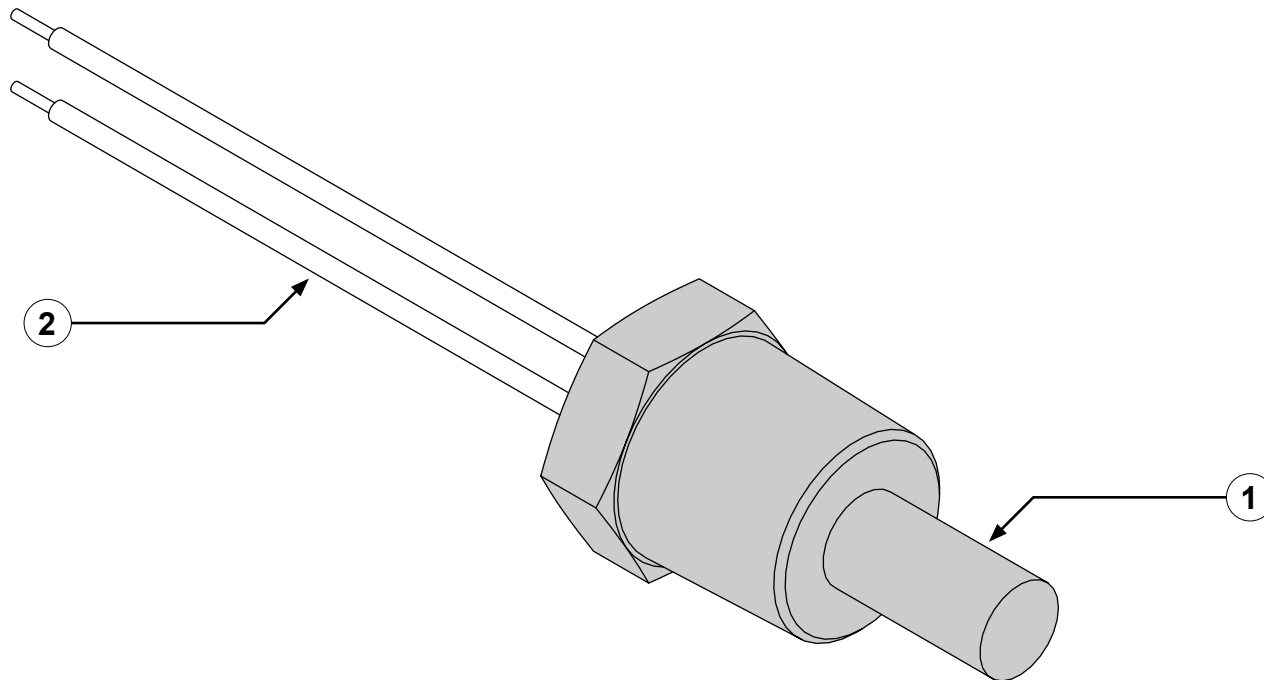

## Hydraulic Temperature Switch

---

| Feature             | Description   |
|---------------------|---|
| 1 Temperature probe | This measures the hydraulic fluid temperature—1/2 NPT.  |
| 2 Wire leads        | These connect to a solenoid and power.<br><b>Note:</b> <i>The wire leads are non-polarized and either wire can be connected to the solenoid or power.</i> |

## Hydraulic Suction Strainer

The suction strainer filters debris from the hydraulic fluid before it exits the reservoir.

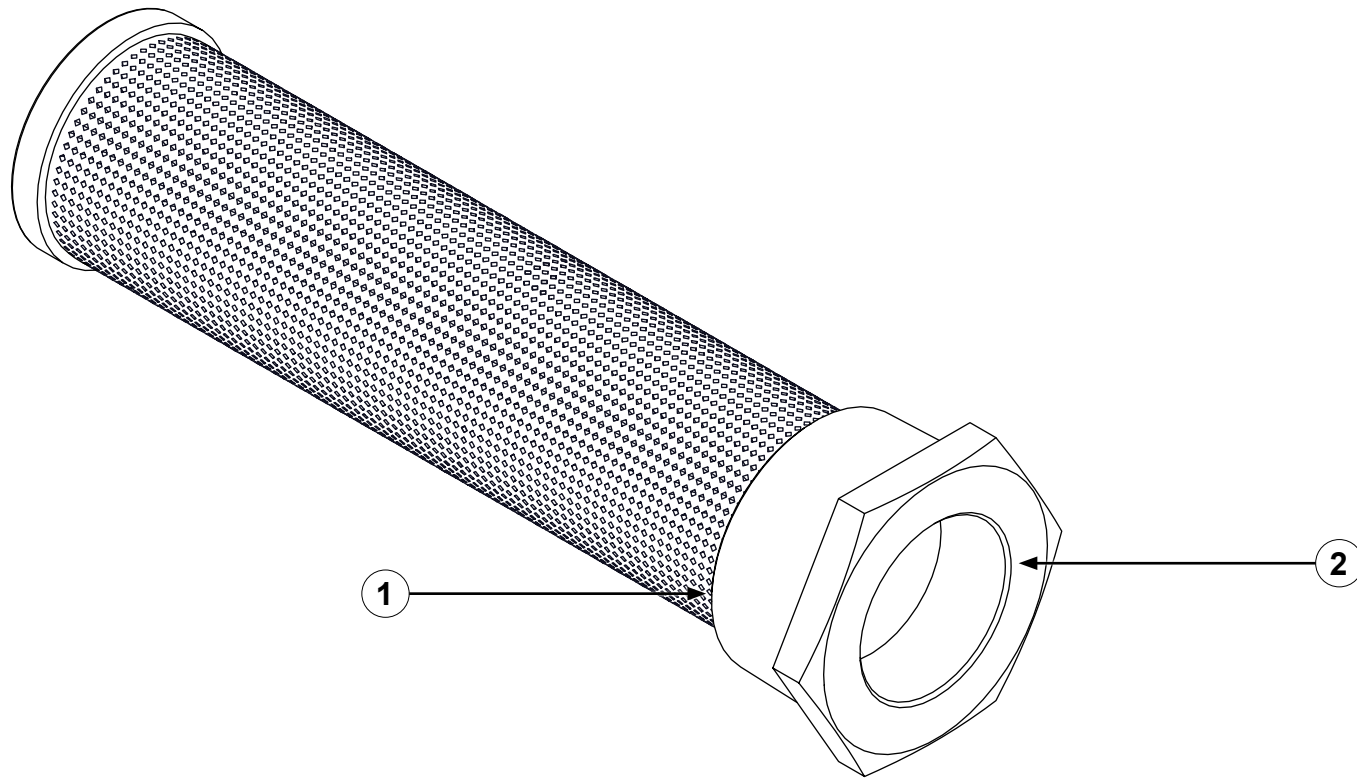



## Hydraulic Suction Strainer

---

| Feature         | Description  |
|-----------------|--|
| 1 Strainer body | This filters debris from the hydraulic fluid—2 MNPT.                   |
| 2 Outlet        | This is where the outlet fitting threads into the strainer—1-1/4 FNPT. |

## Hydraulic Filter Components

The hydraulic filter assembly filters the hydraulic fluid and contains the filter head, filter, and filter indicator.

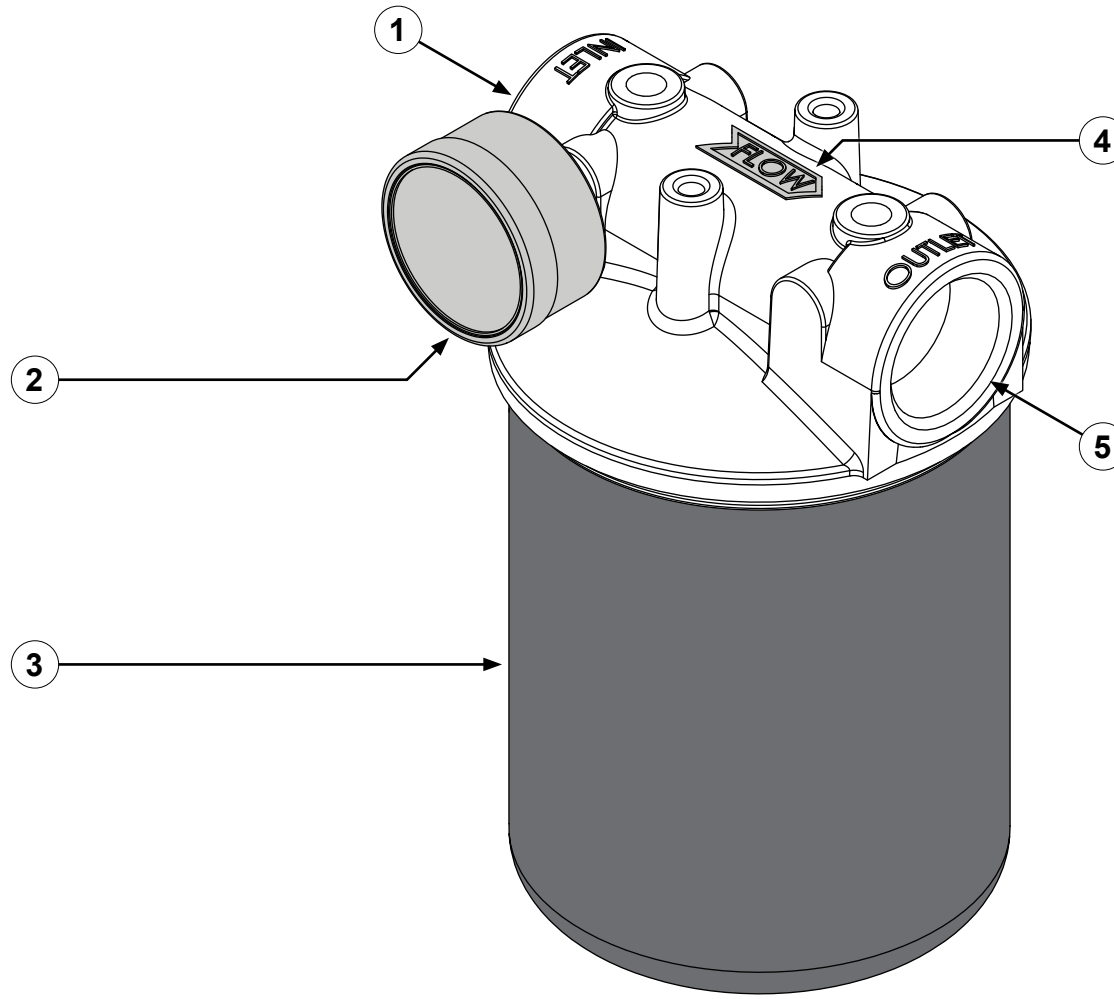

## Hydraulic Filter Components

---

| Feature              | Description   |
|----------------------|---|
| 1 Filter head inlet  | This is the inlet for the hydraulic fluid—1-1/4 NPT.  |
| 2 Filter indicator   | This indicates the filter condition.                  |
| 3 Filter             | This filters the hydraulic fluid.                     |
| 4 Flow indicator     | This indicates the direction of flow.                 |
| 5 Filter head outlet | This is the outlet for the hydraulic fluid—1-1/4 NPT. |

## Concentrate Strainer

The concentrate strainer collects debris that would otherwise flow into the system and potentially damage the concentrate pump.

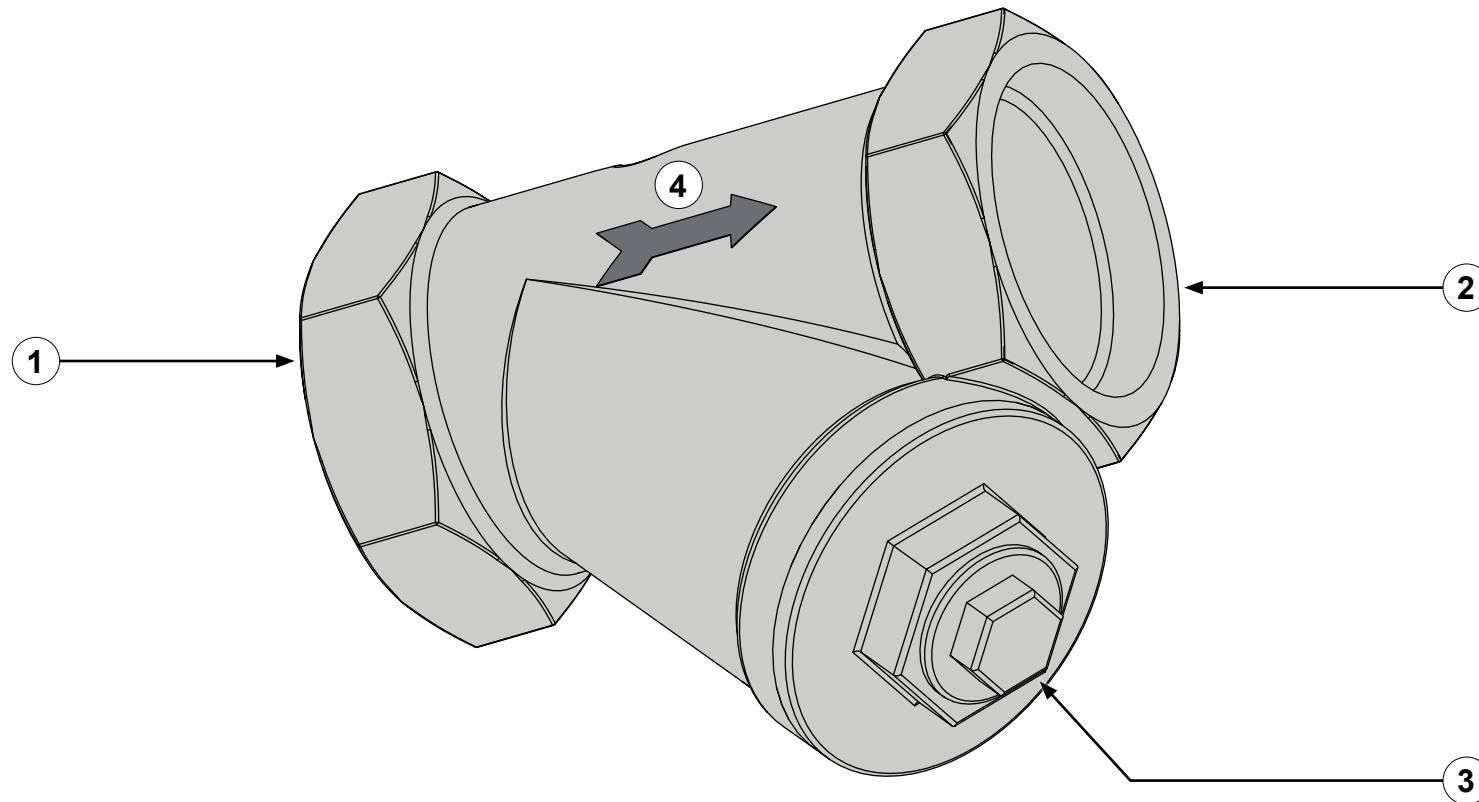

## Concentrate Strainer

---

| Feature            | Description  |
|--------------------|--|
| 1 Inlet            | This is where the concentrate enters the strainer—3 NPT.             |
| 2 Outlet           | This is where the concentrate exits the strainer—3 NPT.              |
| 3 Drain valve port | This allows a drain valve to be installed into the strainer—3/4 NPT. |
| 4 Flow direction   | This is the direction of flow.                                       |

## Pressure Relief Valve

The pressure relief valve limits the pressure in the concentrate discharge manifold by opening when the pressure reaches a predetermined level.

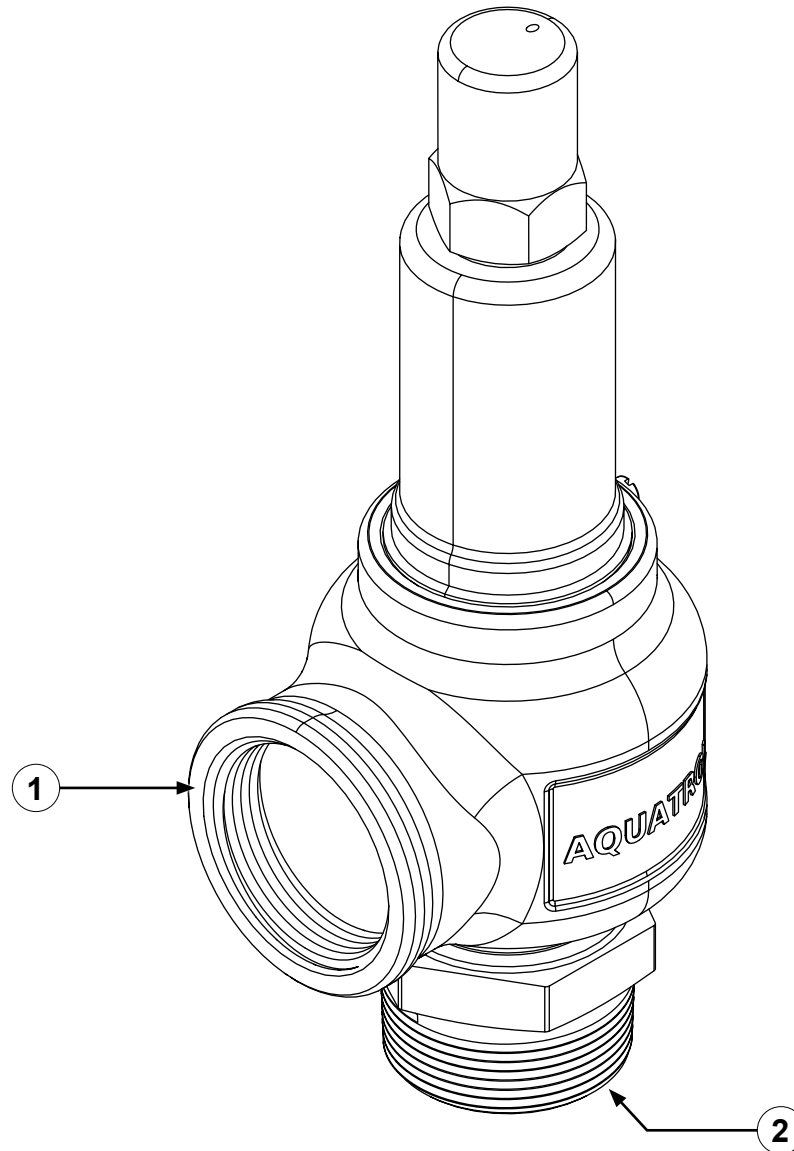

## Pressure Relief Valve

---

| Feature  | Description   |
|----------|---|
| 1 Outlet | This is where the concentrate exits the pressure relief valve—1-1/2 NPT.  |
| 2 Inlet  | This is where the concentrate enters the pressure relief valve—1-1/2 NPT. |

## Pressure Transducer

The pressure transducer measures the pressure of different lines in the system.

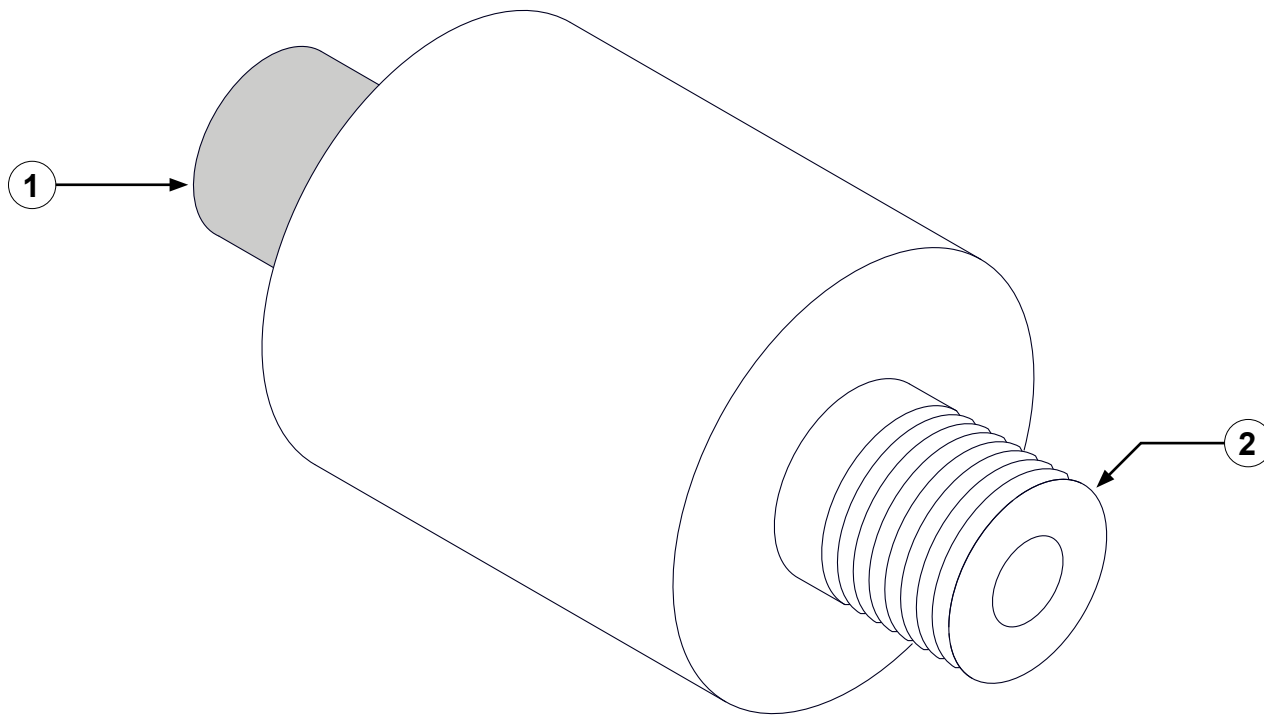



## Pressure Transducer

---

| Feature               | Description  |
|-----------------------|--|
| 1 M12 connector       | This connects to the control box through a sensor cable or to the node controller Y-splitter when the water discharge pressure is unable to be measured at the pump. |
| 2 Pressure transducer | This measures the pressure in the line—1/4 NPT, 0–500 psi.   |

### 3.0 Meter Sensor Cable

The sensor cable communicates data between the various connections. It is typically yellow, gray, or black. The sensor cable is not interchangeable with the CAN cable. You can connect 2 or more cables together to achieve a desired length.

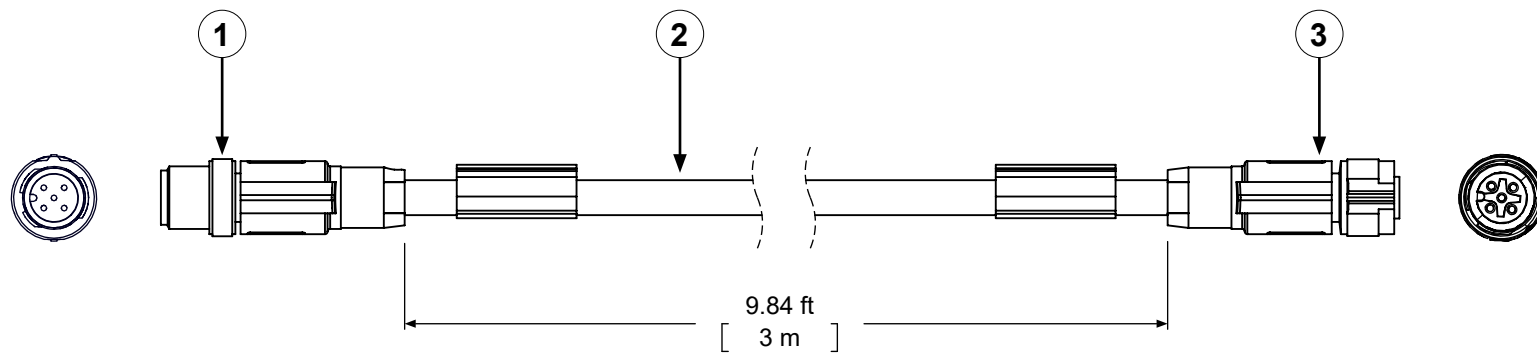

| Feature         | Description  |
|-----------------|--|
| 1 M12 connector | This is a male connector.                                |
| 2 Cable         | This is typically a yellow, gray, or black cable jacket. |
| 3 M12 connector | This is a female connector.                              |

## 0.5 Meter Sensor Cable

The sensor cable communicates data between the various connections. It is typically yellow, gray, or black. The sensor cable is not interchangeable with the CAN cable. You can connect 2 or more cables together to achieve a desired length.

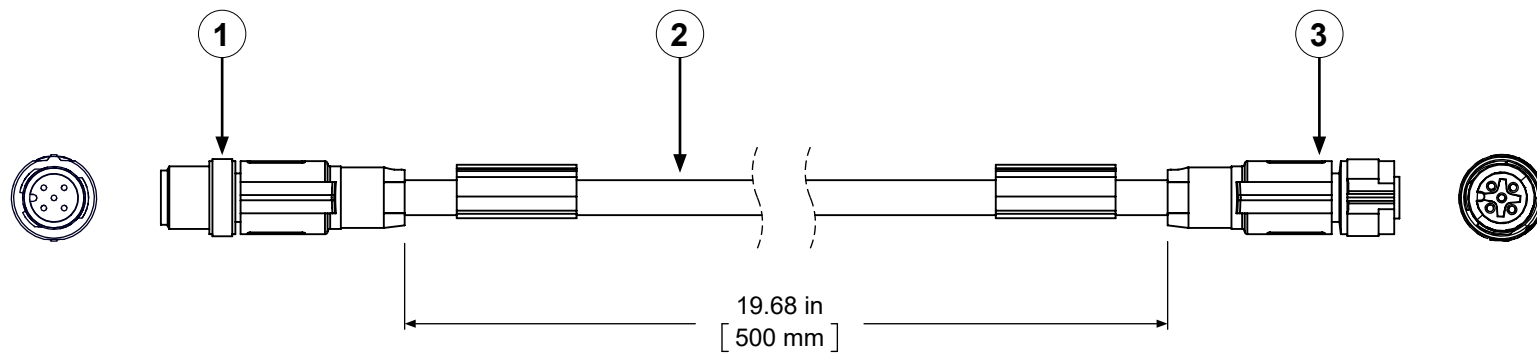

| Feature         | Description  |
|-----------------|--|
| 1 M12 connector | This is a male connector.                                |
| 2 Cable         | This is typically a yellow, gray, or black cable jacket. |
| 3 M12 connector | This is a female connector.                              |

## Concentrate Pump Cable

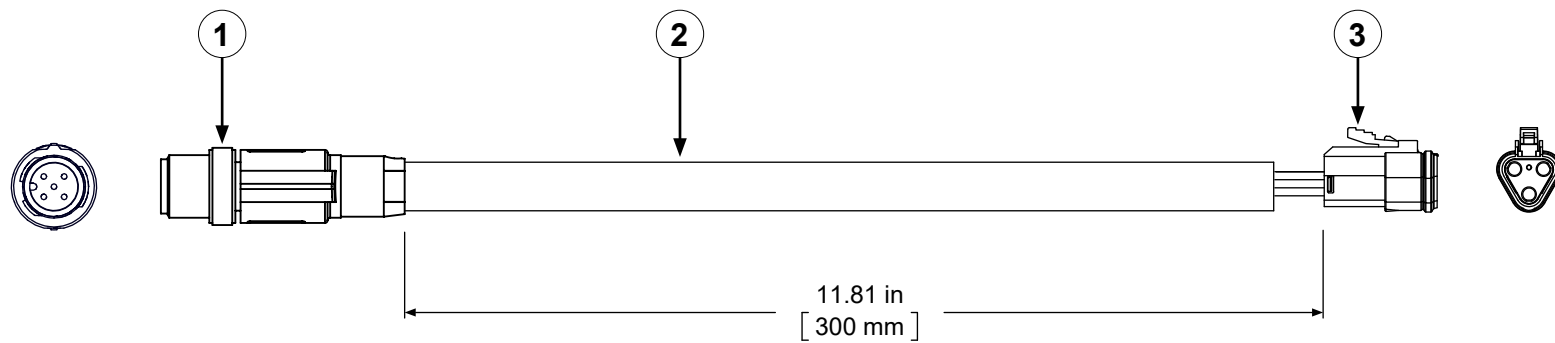

| Feature         | Description  |
|-----------------|--|
| 1 M12 connector | This connects to the concentrate pump connector on the control box or a sensor cable connected to the control box. |
| 2 Cable         | This is a yellow cable jacket.   |
| 3 Connector     | This connects to the speed sensor connector on the concentrate pump.   |

## Concentrate Pump Cable—Schematic

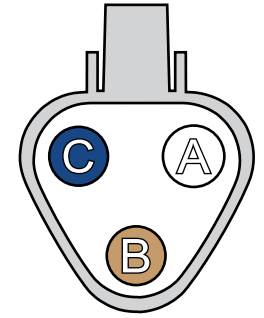
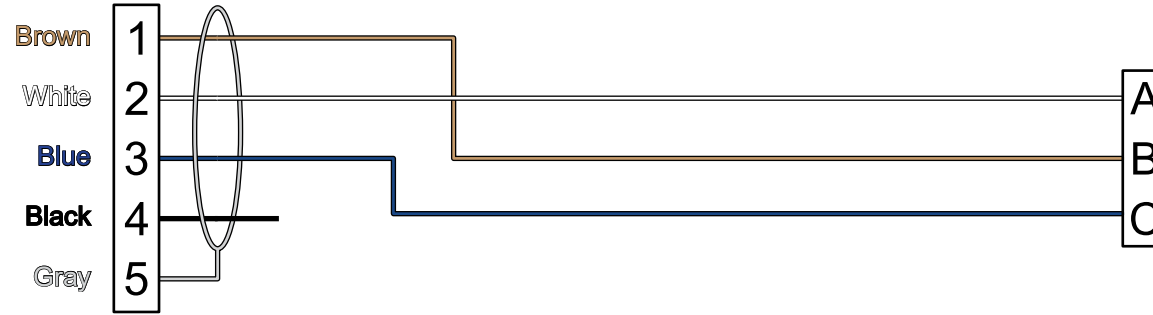
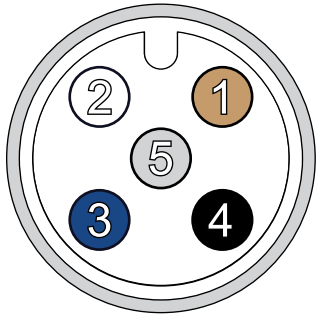

### M12 Connector

- |   |            |
|---|------------|
| 1 | Vcc, +24 V |
| 2 | Signal     |
| 3 | Ground     |
| 4 | N/C        |
| 5 | Shield     |

Phoenix Contact—1405879 or equivalent

### Connector

- |   |            |
|---|------------|
| A | Signal     |
| B | Vcc, +24 V |
| C | Ground     |

Shell—934452102 (1)

Wedge—934482003 (1)

Sockets—match to counterpart or equivalents

## Hydraulic Pump Cable

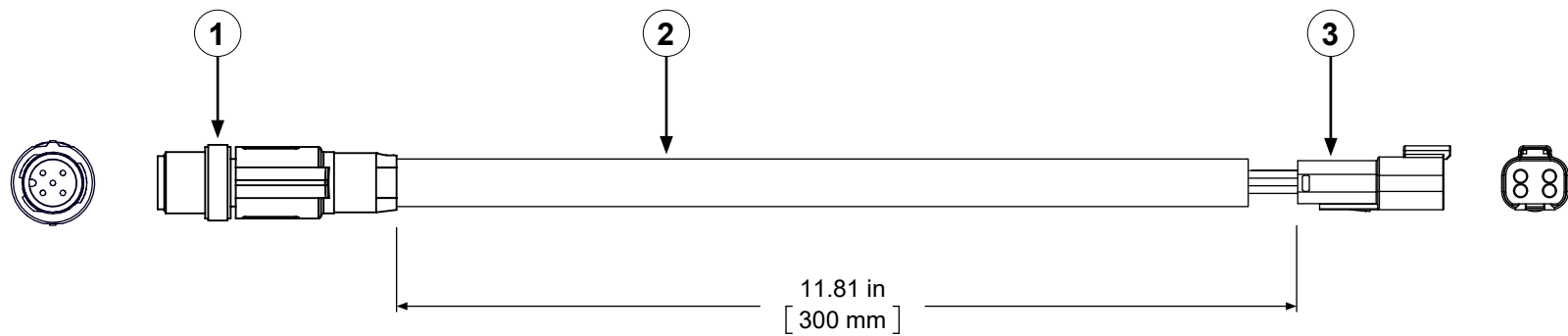

| Feature         | Description  |
|-----------------|--|
| 1 M12 connector | This connects to the hydraulic pump connector on the control box or a sensor cable connected to the control box. |
| 2 Cable         | This is a yellow cable jacket.   |
| 3 Connector     | This connects to the swashplate connector on the hydraulic pump.   |

## Hydraulic Pump Cable—Schematic

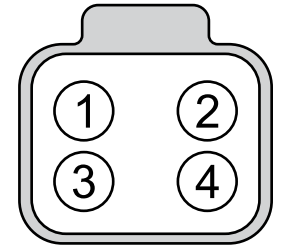

### M12 Connector

- |   |               |
|---|---------------|
| 1 | PWM out—AB    |
| 2 | PWM out—CD    |
| 3 | PWM return—AB |
| 4 | PWM return—CD |
| 5 | Shield        |

Phoenix Contact—1405879 or equivalent

### Connector

- |   |               |
|---|---------------|
| 1 | PWM out—AB    |
| 2 | PWM out—CD    |
| 3 | PWM return—AB |
| 4 | PWM return—CD |

Shell—934453102 (1)

Wedge—934483003 (1)

Sockets—match to counterpart or equivalents

## Notes



## Installation Overview

This equipment is intended to be installed by a person or persons with the basic knowledge of installing similar equipment. Contact Waterous with questions about installing the equipment. The installation may require the following tasks and abilities:

- Locating, drilling, and cutting features into the apparatus.
- Routing and securing the wiring.
- Calibration and final testing.

## Preparing for the Installation

Use the following guidelines before, during, and after the installation.

- Read and understand all the installation instructions before installing the equipment.
- Prepare a suitable, well-lit area and gather all the necessary tools before you begin the installation.
- Make sure that you remove any shipping plugs or caps before installing the component.
- Make sure that you bring all fluids to operating levels before using the equipment.

## NOTICE

### Before Operation

- Read and understand all the instructions provided.
- Check all fluid levels and replenish if necessary.
- Remove all shipping plugs and install the operation plugs or caps.



## Modifying the Equipment

This equipment is intended to operate as designed. Do not remove, modify, or change the components in the system. Doing so will void the warranty. Contact Waterous for more information.

## NOTICE

### Modification

- Modifying the equipment can damage components and void your warranty.
- Do not modify the system or any of its components.

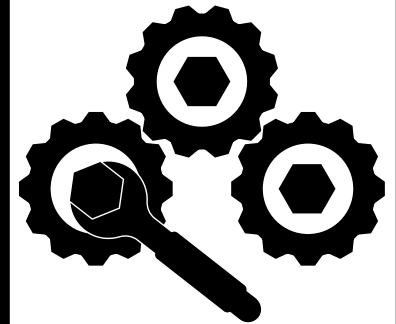

*Do not modify the system or any components. Doing so will void your warranty.*

## Optional Equipment

Be aware that the installation instruction may include optional equipment not included in your application.

## Determining Cable and Wire Routing

Use the *Wiring Best Practices* document, available at [www.waterousco.com](http://www.waterousco.com), as a guide to select and route wiring for your application.

## Plumbing Layout

Use the illustration as a guide to lay out the plumbing connections for your application.

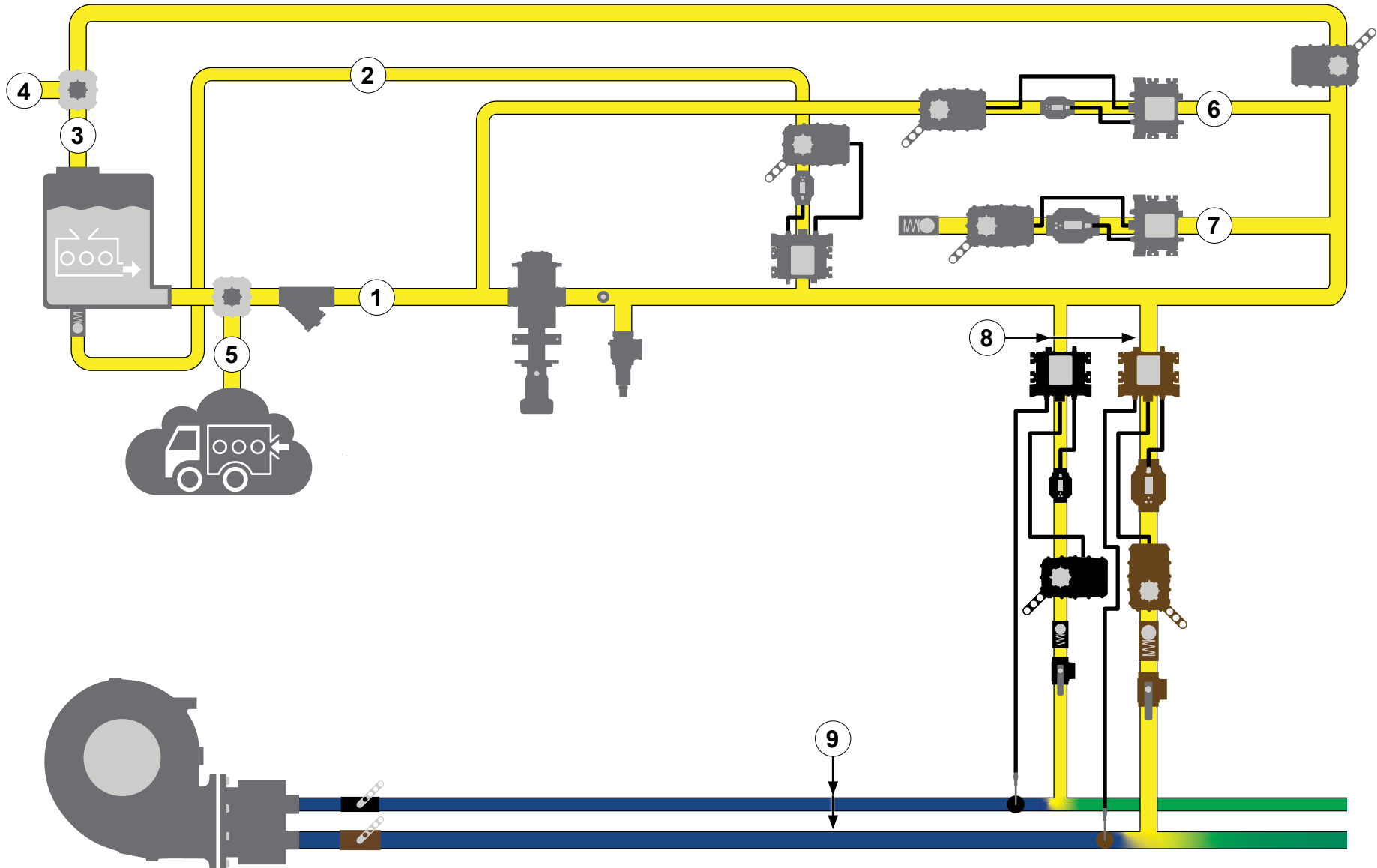

## Plumbing Layout

| Feature                             | Description  |
|-------------------------------------|--|
| 1 Concentrate supply line           | This transports concentrate around the system. This is a low-pressure line.  |
| 2 Concentrate supply refill line    | This allows you to fill the on-board tank from an auxiliary source. This is a low-pressure line.   |
| 3 Priming line                      | This evacuates air from the concentrate pump inlet as the system primes before operation. This is a low-pressure line.   |
| 4 Priming bypass line               | This prevents contamination to the concentrate during testing and training. When water is substituted for concentrate during training or testing, and there is concentrate in the supply tank, this bypass valve diverts water from the supply tank to prevent concentrate contamination. It is also very important to make sure that you drain any remaining water in the line before priming the system with concentrate. This is a low-pressure line. |
| 5 Auxiliary concentrate supply line | This allows you to source concentrate from an external source. This is a low-pressure line.  |
| 6 Low-flow bypass line              | This returns a portion of the pumped concentrate in the supply line back to the pump inlet when the desired concentrate output requires the pump to operate at an rpm that is lower than its capabilities. This is a low-pressure line.  |
| 7 Transfer line                     | This line allows you to transfer or relay concentrate to another location. This is a high-pressure line.   |
| 8 Discharge line assembly           | This manages the concentrate injected into the solution-capable discharge. This is a high-pressure line.   |
| 9 Solution-capable discharge        | This transports clear water and is capable of creating a foam solution. This is a high-pressure line.  |

## Concentrate Supply Component Location

Use the illustration and table to understand the hydraulic component location in the plumbing layout.

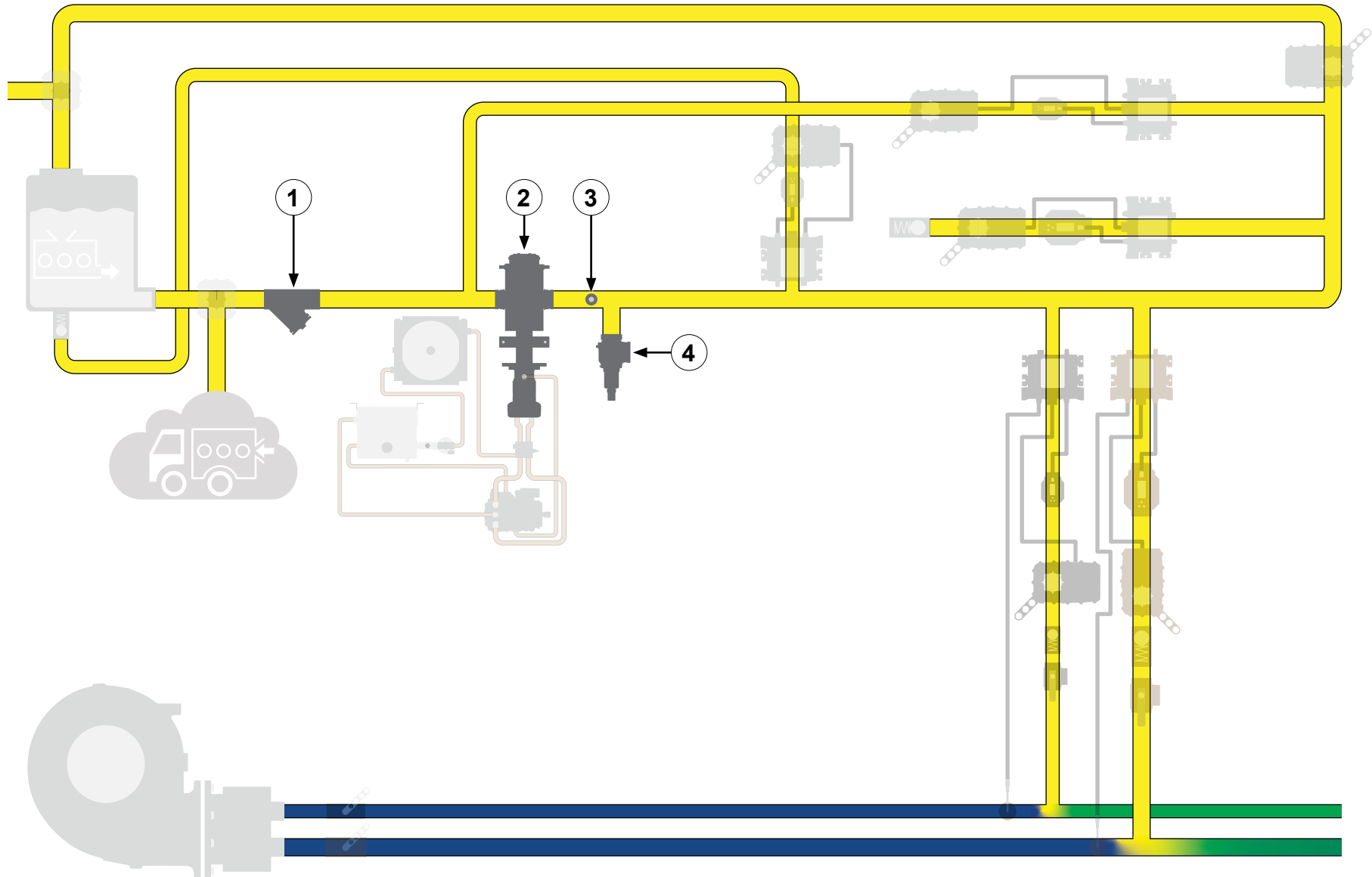

## Concentrate Supply Component Location

---

| Feature                 | Description  |
|-------------------------|--|
| 1 Concentrate strainer  | This collects debris that would otherwise flow through the system and potentially damage the concentrate pump.             |
| 2 Concentrate pump      | This circulates the foam concentrate through the system.   |
| 3 Pressure transducer   | This measures the pressure in the concentrate discharge line.  |
| 4 Pressure relief valve | This limits the pressure in the concentrate discharge manifold by opening when the pressure reaches a predetermined level. |

## Hydraulic Component Layout

Use the illustration and table to understand the relationship between the hydraulic components and hose connections.

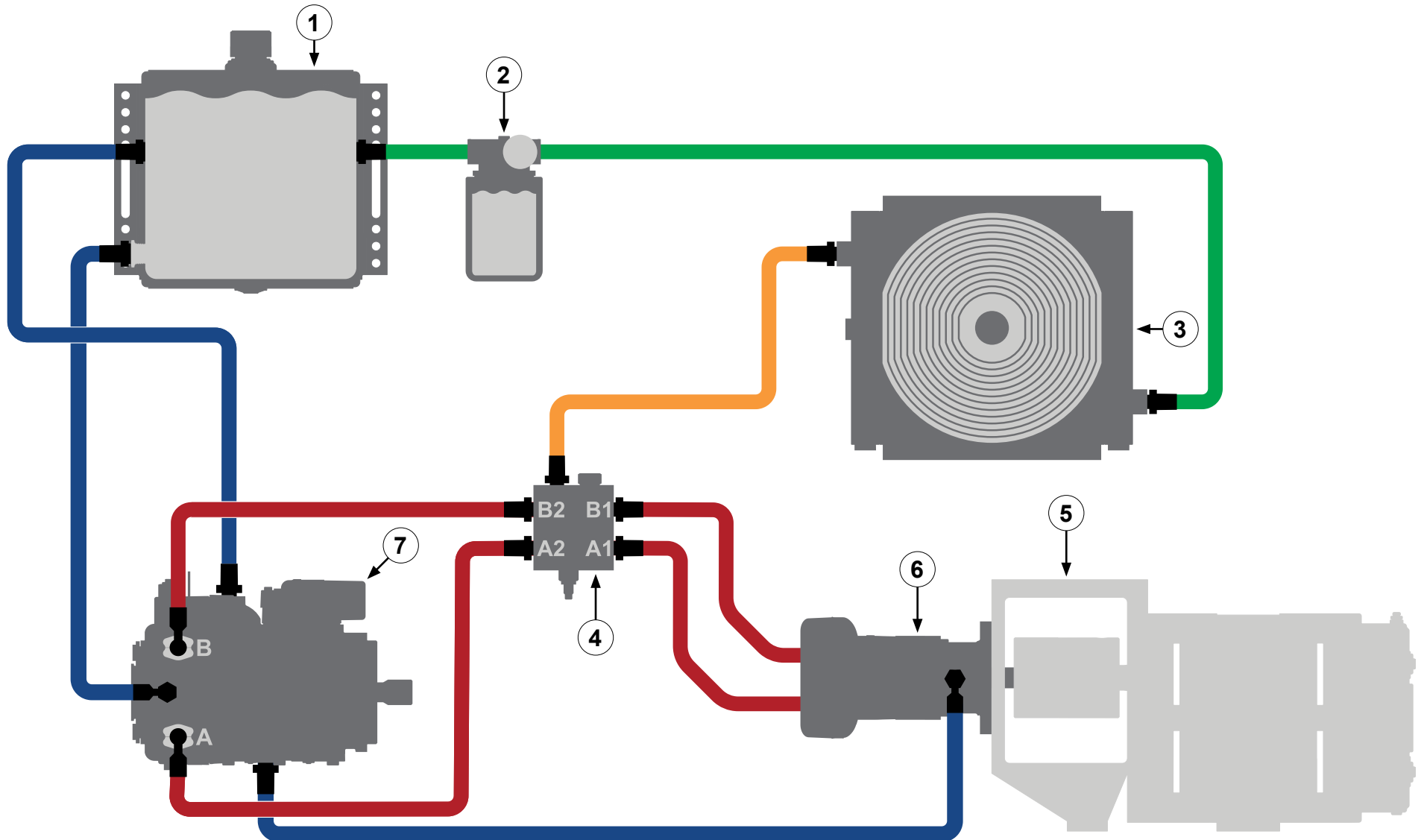

## Hydraulic Component Layout

---

| Feature                    | Description  |
|----------------------------|--|
| 1 Hydraulic reservoir      | This holds hydraulic fluid.  |
| 2 Hydraulic filter         | This filters the hydraulic fluid.  |
| 3 Hydraulic heat exchanger | This uses a pusher fan to cool the hydraulic fluid.  |
| 4 Loop flush manifold      | This draws hot hydraulic fluid from the main hydraulic lines and sends it to the heat exchanger. |
| 5 Concentrate pump         | This transports the concentrate through the system.  |
| 6 Hydraulic motor          | This drives the concentrate pump.  |
| 7 Hydraulic pump           | This drives the hydraulic motor.   |

## Installing the Hydraulic Hoses

Use the illustration and table to install the hydraulic hoses. All hoses, connectors, and fittings are supplied by the installer.

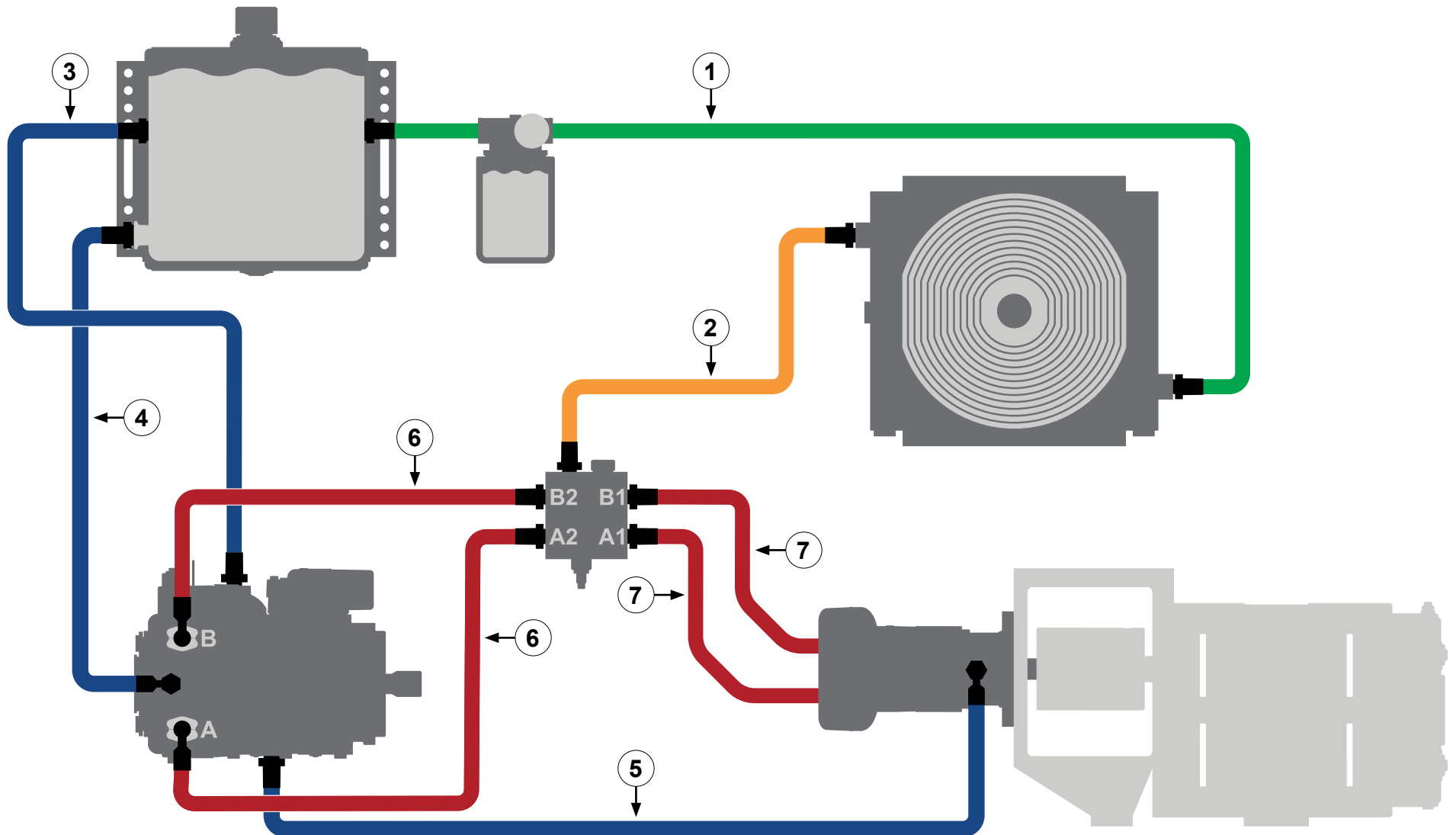



## Hydraulic Hoses—Overview

| Hose   | First Connector                        | Second Connector                        |
|--|--|---|
| 1 Hydraulic filter to heat exchanger—3/4-inch    | Filter end—1-1/4 NPT                   | Heat exchanger end—#16 SAE              |
| 2 Heat exchanger to loop flush manifold—1/2-inch | Heat exchanger end—#16 SAE             | Manifold end—#8 SAE                     |
| 3 Hydraulic pump to hydraulic reservoir—3/4-inch | Pump end—#12 SAE                       | Reservoir end—1-1/4 NPT                 |
| 4 Hydraulic reservoir to hydraulic pump—3/4-inch | Reservoir end—2 NPT                    | Pump end—#16 SAE                        |
| 5 Hydraulic pump to concentrate pump—3/4-inch    | Pump end—#12 SAE                       | Motor end—#6 SAE                        |
| 6 Hydraulic pump to loop flush manifold—1-inch   | Pump end—Code 62, 1-inch, split flange | Manifold end—#16 SAE                    |
| 7 Loop flush manifold to concentrate pump—1-inch | Manifold end—#16 SAE                   | Motor end—Code 62, 1-inch, split flange |

**Note:** All SAE connections are SAE J1926-1 standard O-ring ports.

## Installing the Temperature Switch

---

Use the illustration and instructions to install the temperature switch into the heat exchanger.

- 1 Install the temperature switch into the heat exchanger port.

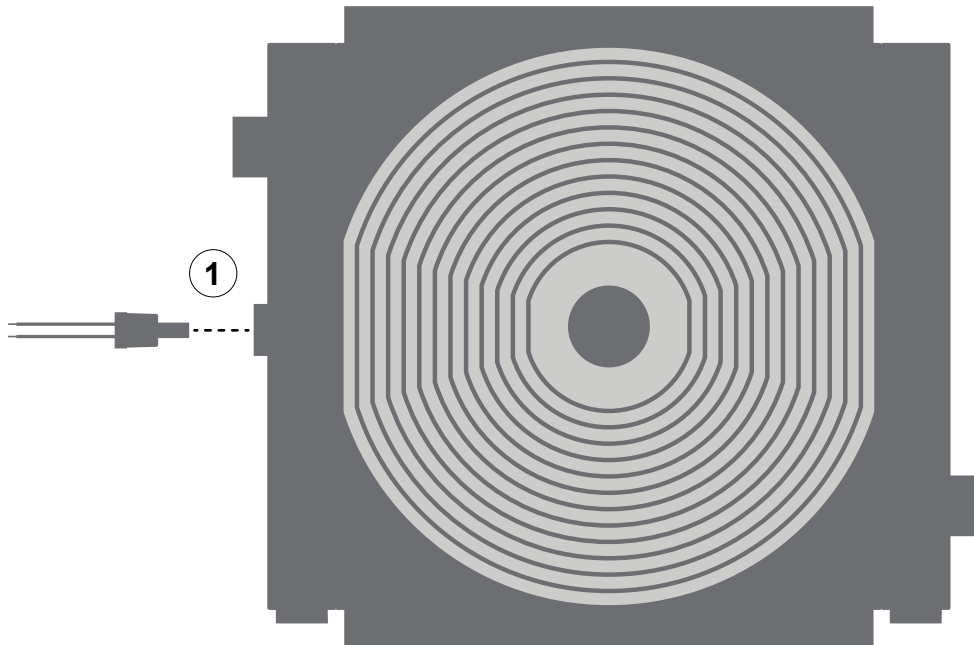

## Installing the Hydraulic Motor and Concentrate Pump

Use the illustration and instructions to connect the hydraulic motor to the concentrate pump.

- 1 Install the concentrate pump into the apparatus and connect it to the concentrate plumbing.  
Refer to: "**Plumbing Layout**" on page 50.
- 2 To install the couplers, do the following:
  - Loosely install the motor hub onto the hydraulic motor.
  - Loosely install the pump hub onto the concentrate pump.
- 3 To complete the installation, do the following:
  - Place the elastomer spider between the hubs.
  - Loosely mount the hydraulic motor onto the concentrate pump.
  - Make any adjustments to the spider coupler, then securely tighten each hub.

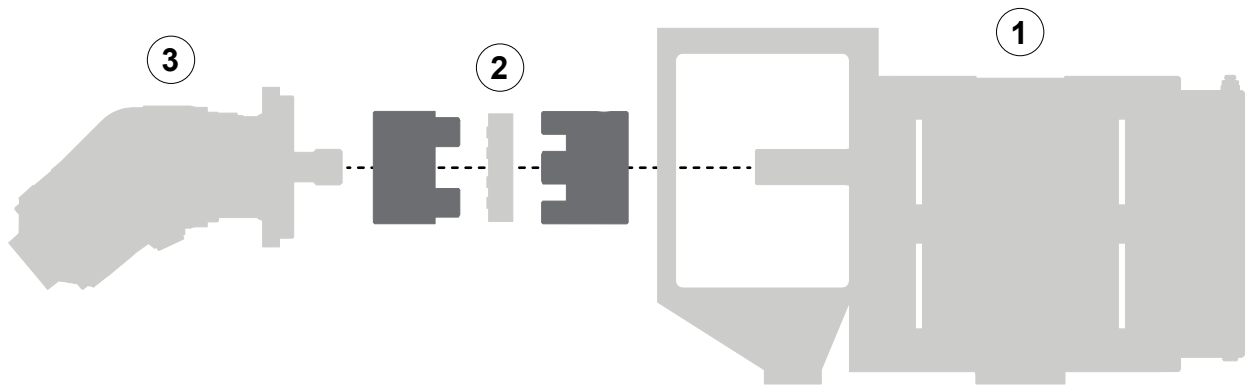

## Assembling the Hydraulic Reservoir

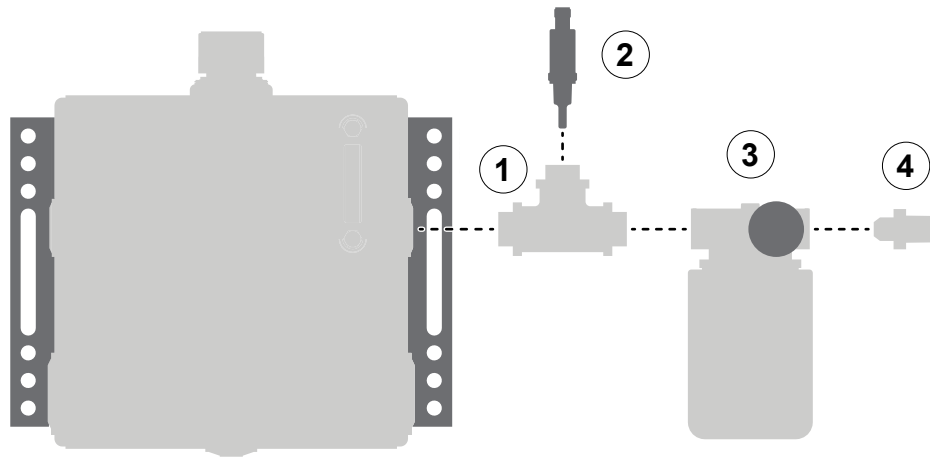

Use the illustrations and instructions to assemble the hydraulic reservoir.

**Note:** The illustrated component locations are not definitive. The ports on the reservoir are mirrored and interchangeable to suit your application.

- 1 Locally source the tee fitting and necessary adapters for the temperature sensor (1/4 NPT) and filter head outlet (1-1/4 NPT). Install the tee fitting into the 1 NPT reservoir port.
- 2 Install the temperature sensor into the tee fitting.
- 3 Install the filter assembly onto the tee fitting.
- 4 Locally source and install a 1-1/4 NPT fitting into the filter head inlet.
- 5 Install the hydraulic suction strainer into the 2 NPT reservoir port.
- 6 Install the level sensor into the 1/4 NPT reservoir port.

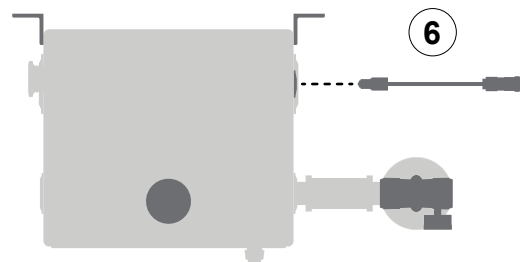

## Installing the Concentrate Strainer

Use the illustration and instructions to install the concentrate strainer.

- 1 Install the concentrate strainer downstream of the concentrate source and upstream of the concentrate pump in the concentrate line. Refer to: **"Plumbing Layout" on page 50.**

Make sure that the strainer is oriented to follow the flow. Refer to: **"Concentrate Strainer" on page 36.**

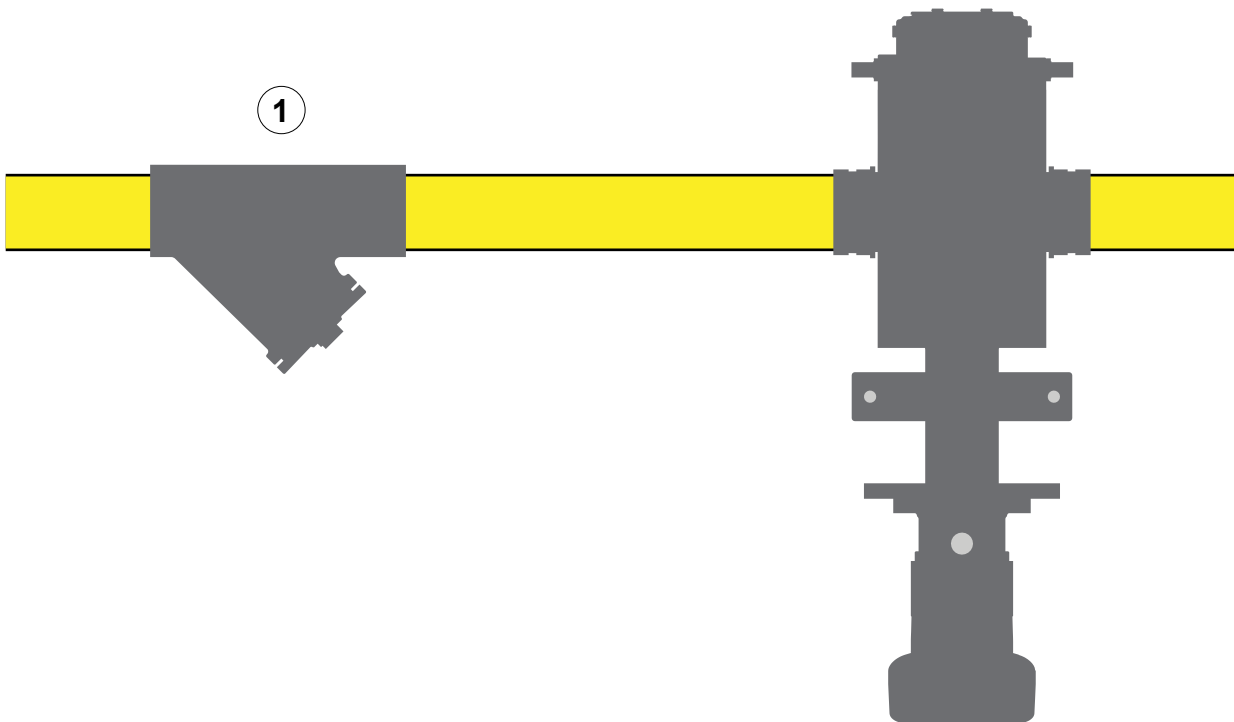

## Installing the Pressure Relief Valve

Use the illustration and instructions to install the pressure relief valve.

- 1 Install the pressure relief valve downstream of the concentrate pump in the concentrate line. Refer to: "**Plumbing Layout**" on page 50.
- 2 Connect the pressure relief valve discharge to an appropriate container or back into the low pressure side of the system to contain any relieved concentrate.

**⚠ Pressure:** May cause personal injury or system damage. When directing high-pressure discharge into the concentrate supply tank, use baffling or other methods to manage the flow.

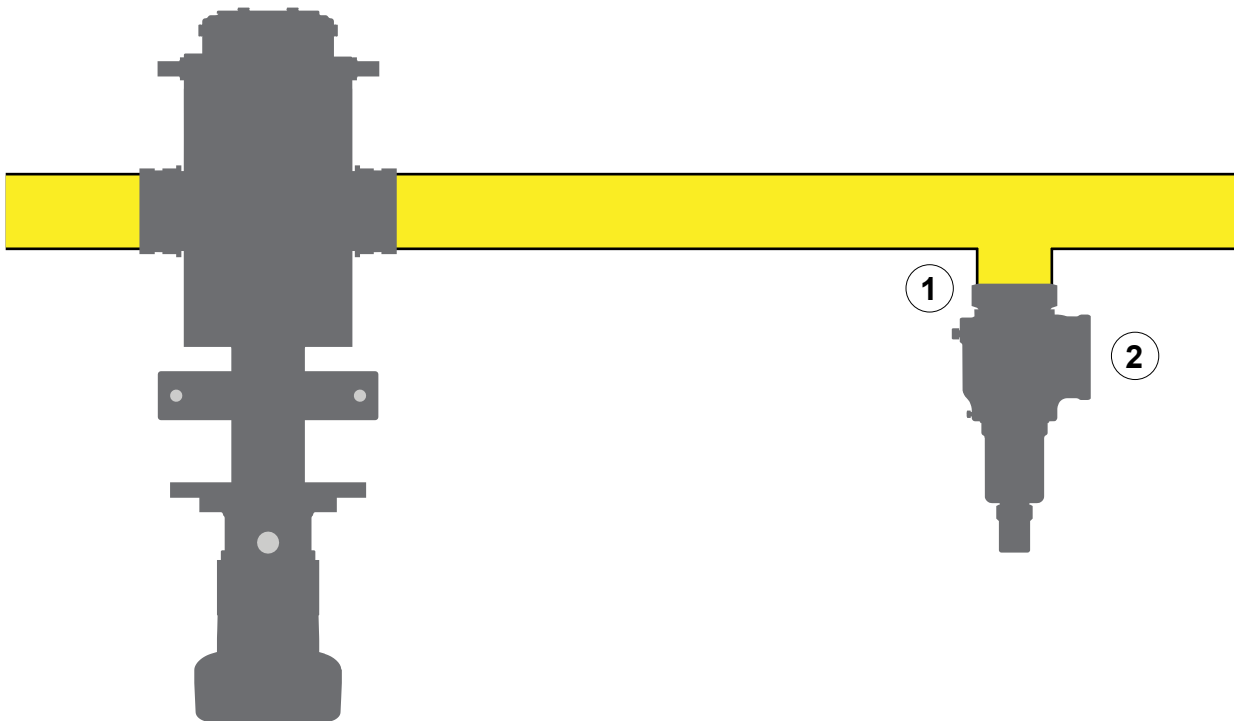

## Installing the Pressure Transducer

Use the illustration and instructions to install the pressure transducer.

- 1 Install the pressure transducer downstream of the concentrate pump in the concentrate line. Make sure that you install the pressure transducer a distance of at least 5 times the inner diameter of the concentrate line and downstream of the concentrate pump outlet. Refer to: "**Plumbing Layout**" on page 50.

**Note:** Do not install the pressure transducer in an elbow section of the plumbing.

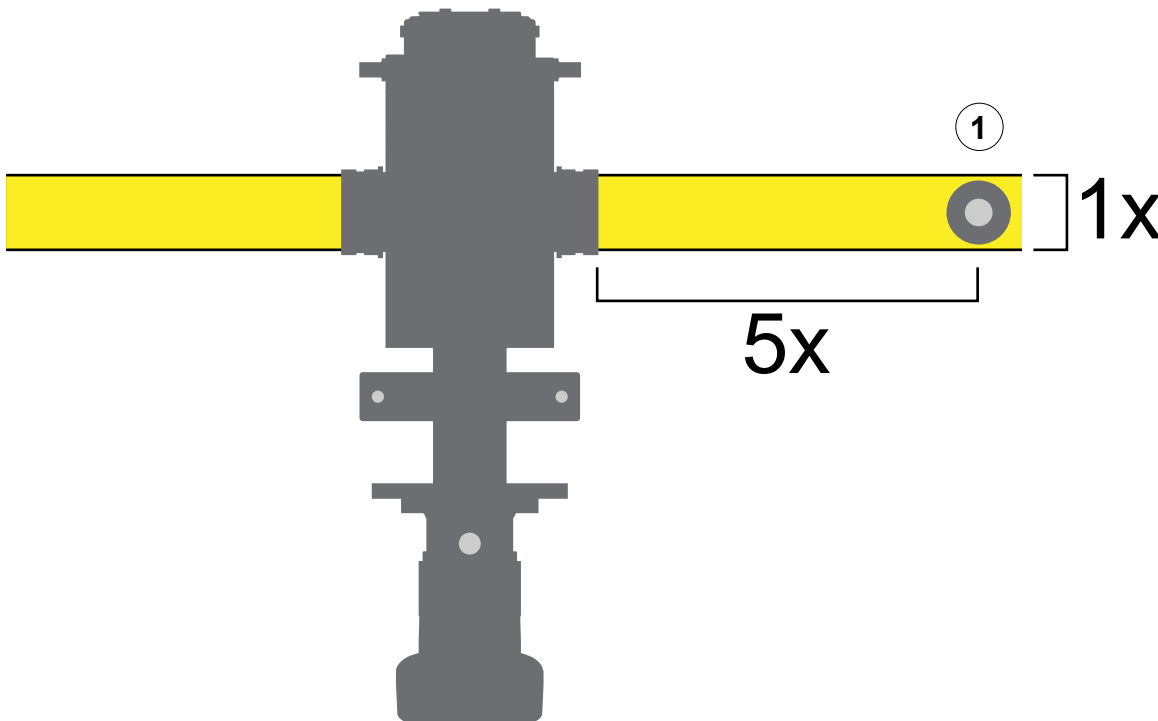

## Connecting the Hydraulic Pump to the Apparatus Drive

Use the illustration and instructions to connect the hydraulic pump to the apparatus driveline.

- 1 Locally source the appropriate components to connect the hydraulic pump to the apparatus drive.

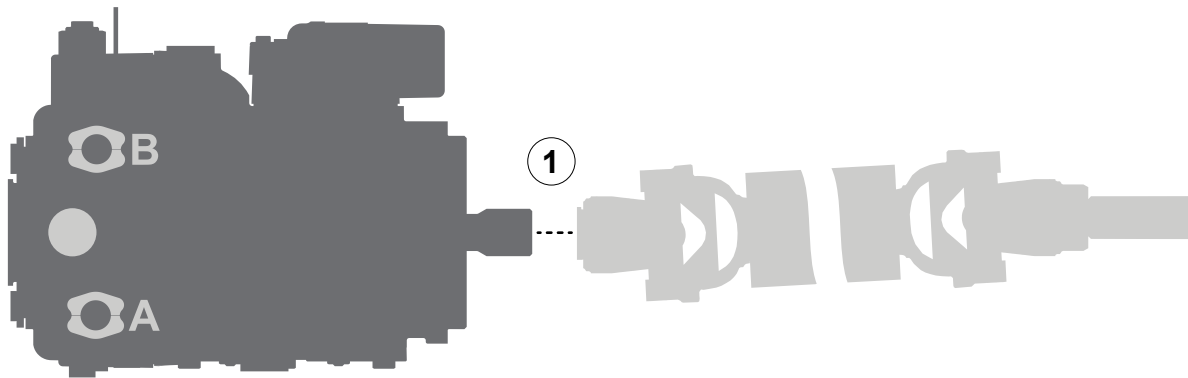



## Connecting the Concentrate Pump and Pressure Transducer

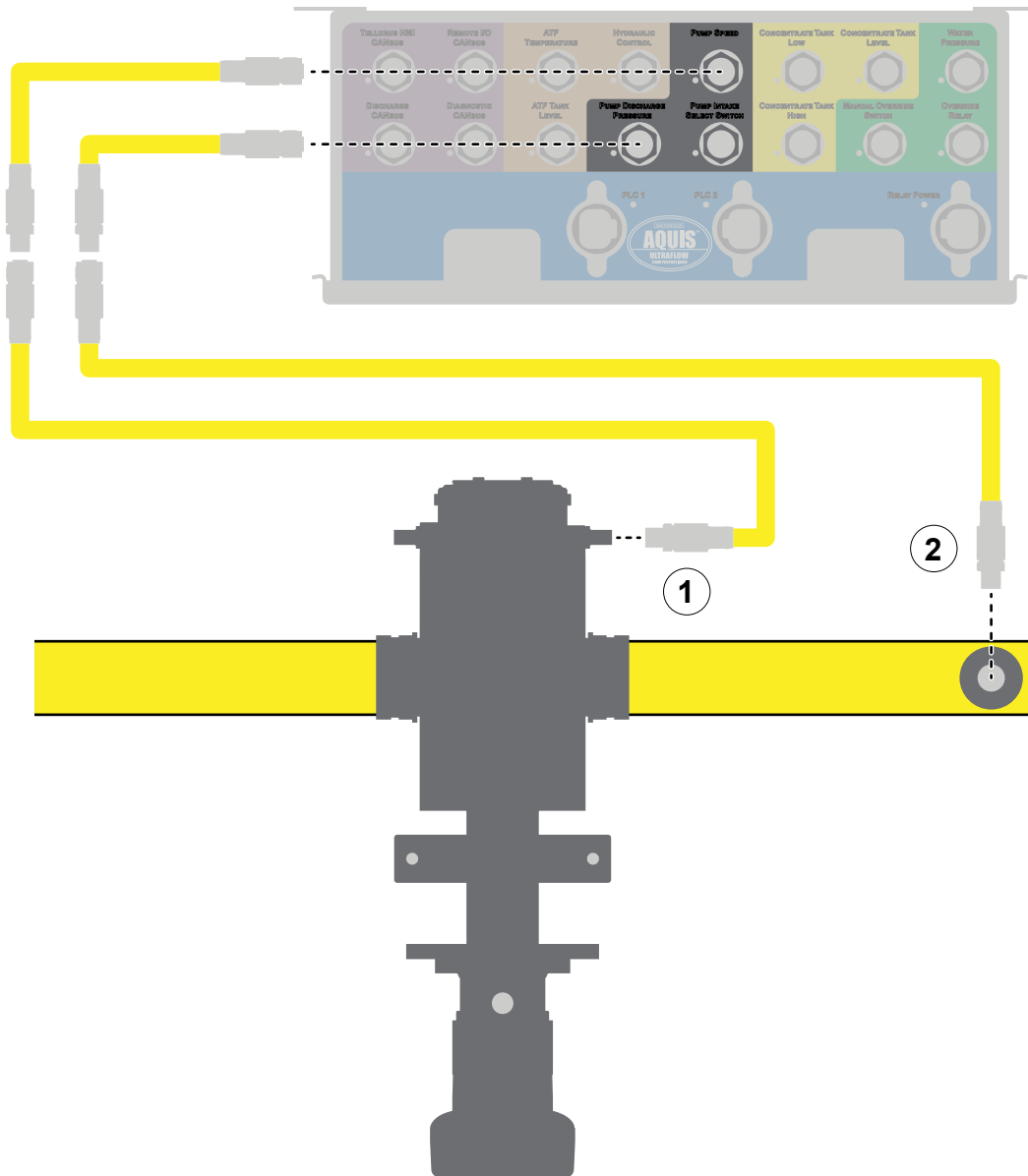

Use the illustration and instructions to connect the concentrate pump speed sensor and concentrate discharge pressure transducer to the control box.

- 1 Use a sensor cable to connect the concentrate pump speed sensor to the control box—pump speed connector.
- 2 Use a sensor cable to connect the pressure transducer to the control box—pump discharge pressure connector.

## Connecting the Hydraulic Sensors and Hydraulic Pump

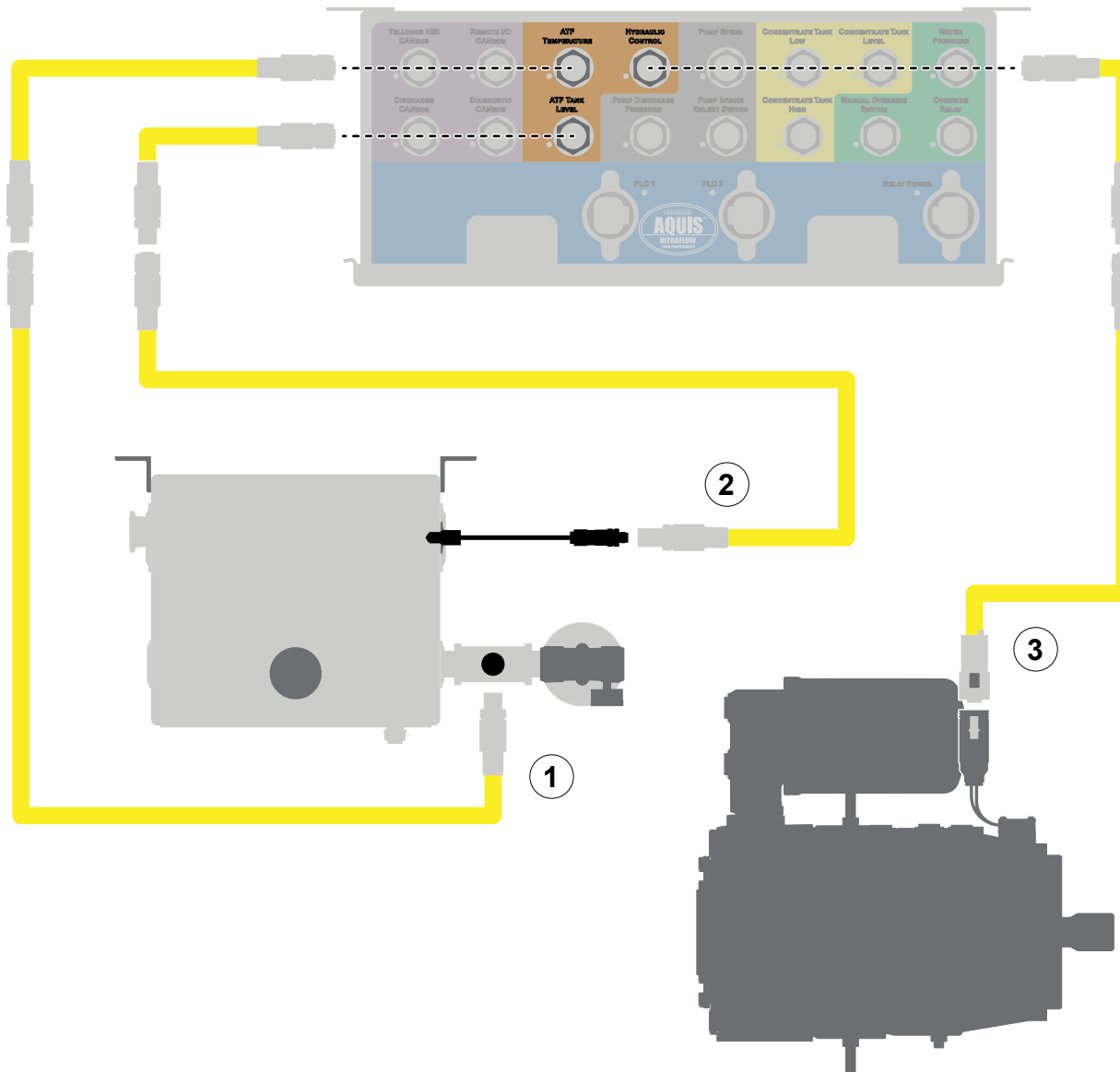

Use the illustration and instructions to connect the hydraulic sensors and hydraulic pump to the control box.

- 1 Use a sensor cable to connect the temperature sensor to the control box—ATF temperature connector.
- 2 Use a sensor cable to connect the level sensor to the control box—ATF tank level connector.
- 3 Use the hydraulic pump cable to connect the hydraulic motor to the control box—hydraulic control connector.

**Note:** A sensor cable can be used to achieve a desired length.

## Operating the Hydraulic System

The hydraulic system is managed by the Aquis UltraFlow control system hardware and software. You can operate the system through the 8-inch or 15-inch Tellurus control panel.

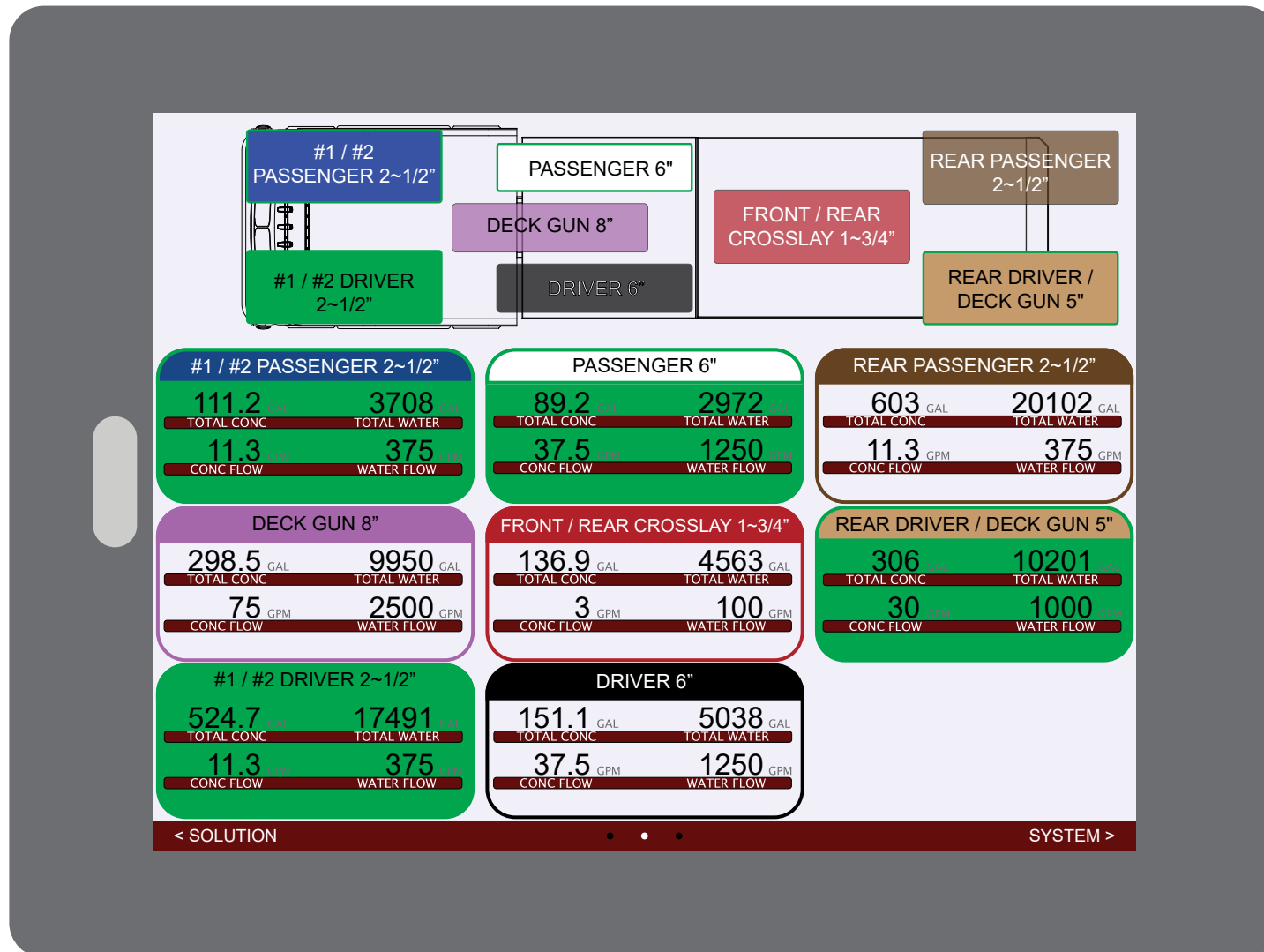

## Maintenance Schedule

---

Use the documentation that you received with your system to develop a maintenance schedule for your specific application. Consider environmental conditions, hours of operation, and other factors specific to your application to develop a suitable maintenance schedule.

## Notes

**WATEROUS**

Waterous Company  
125 Hardman Avenue South  
South Saint Paul, MN 55075  
(651) 450-5000  
[www.waterousco.com](http://www.waterousco.com)