

PTO Compressor Kit (Belt Drive) Service Parts List

Covers the following Models:

CAFS Type			See Index on Page
Traditional	Generated		
	One-Step	Eclipse GEN 2.0	
100-B	100-OSB	100-ECLB	3

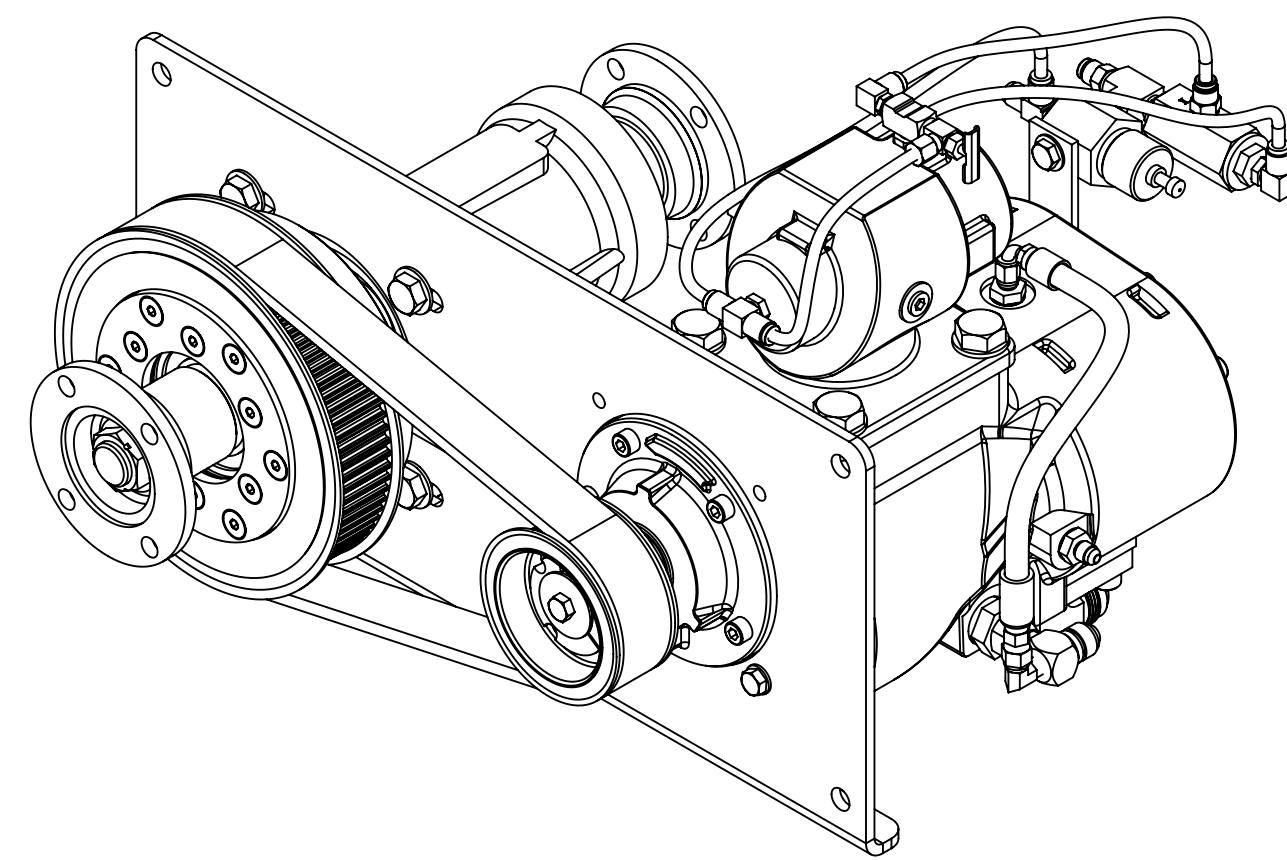

HORIZONTAL DRIVE

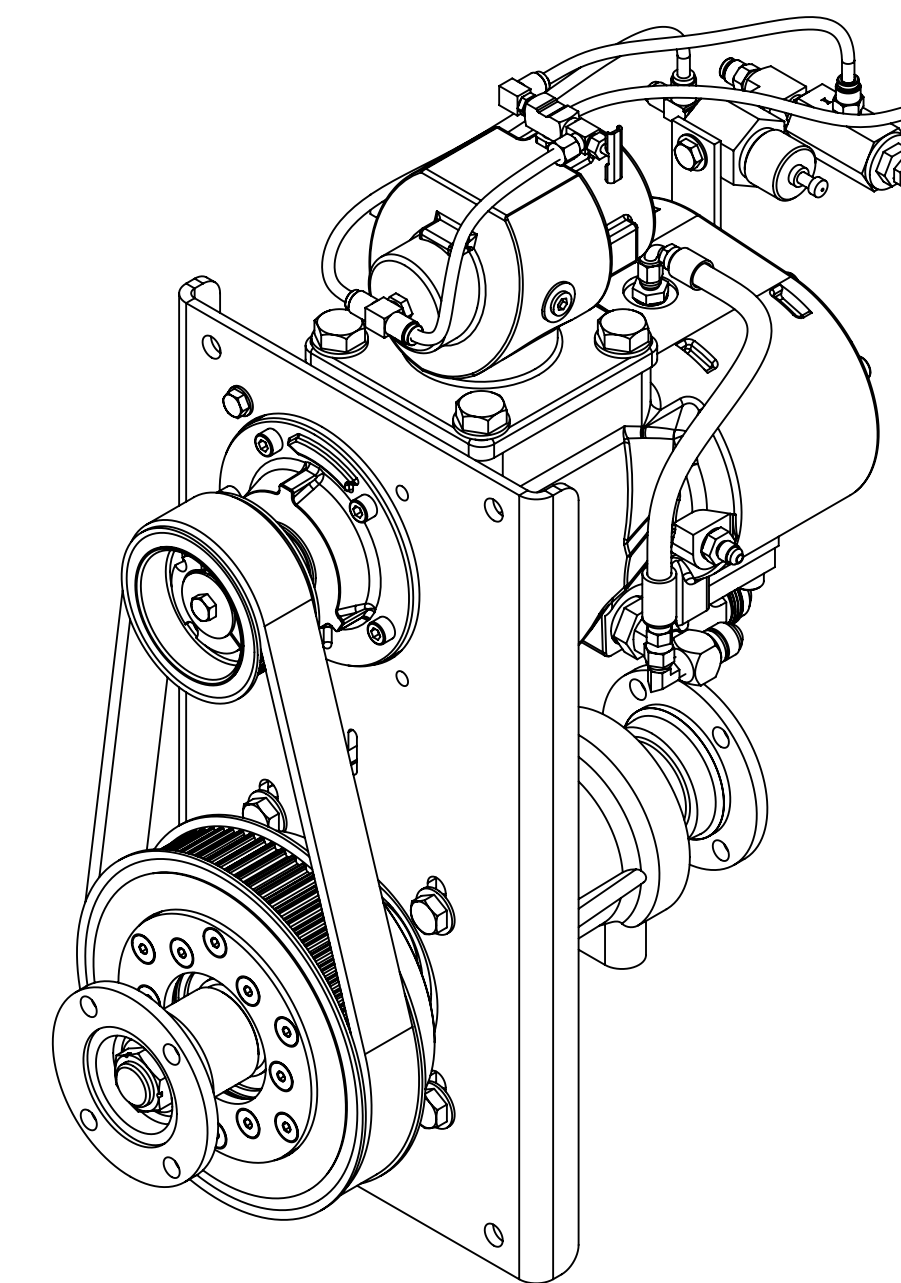

VERTICAL DRIVE

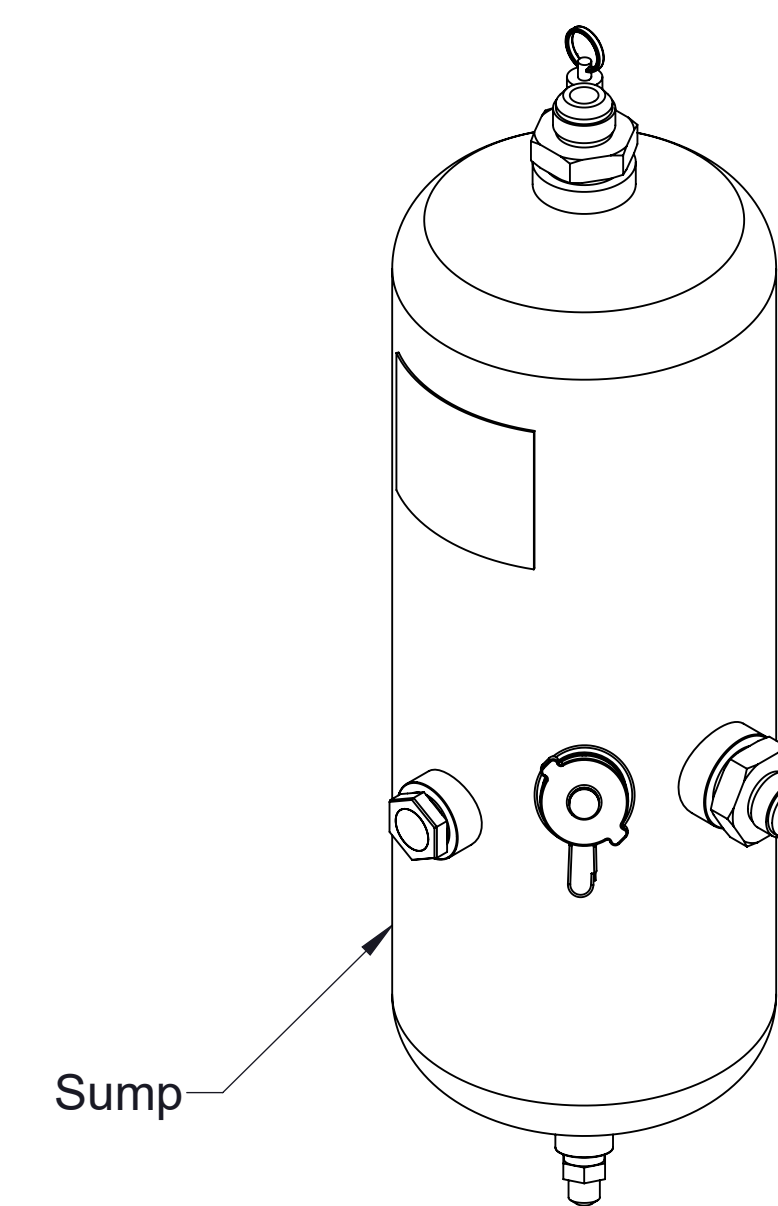
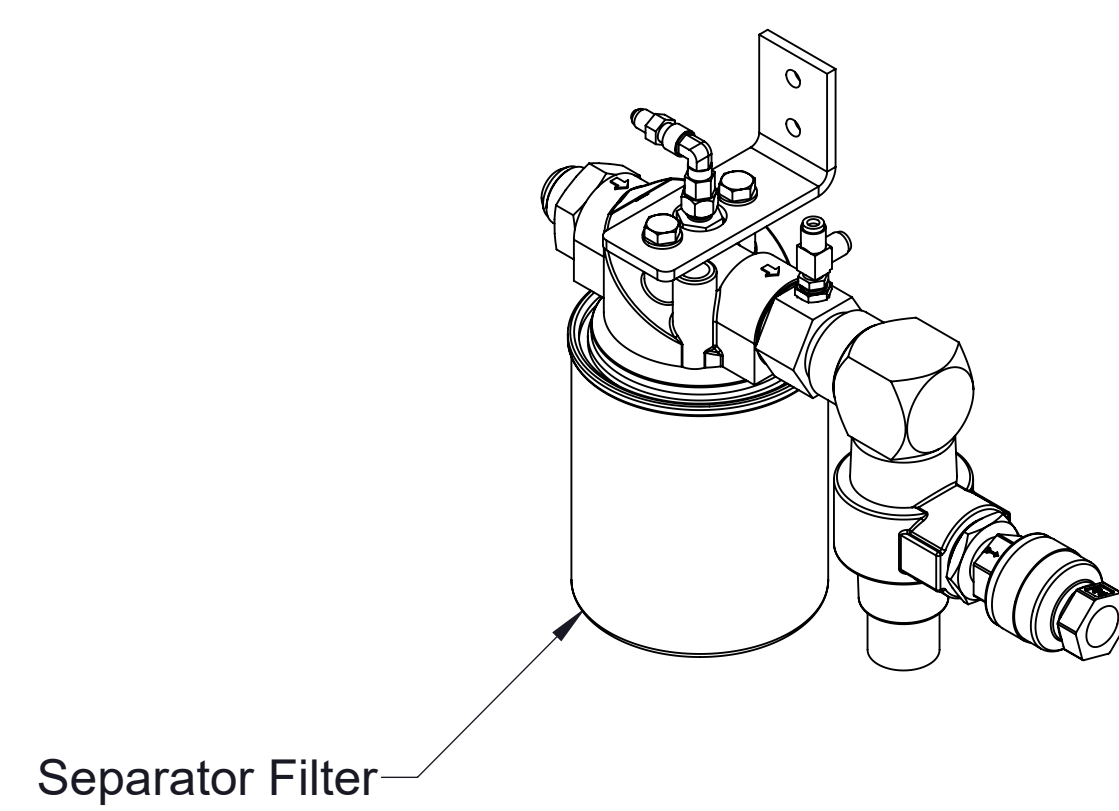
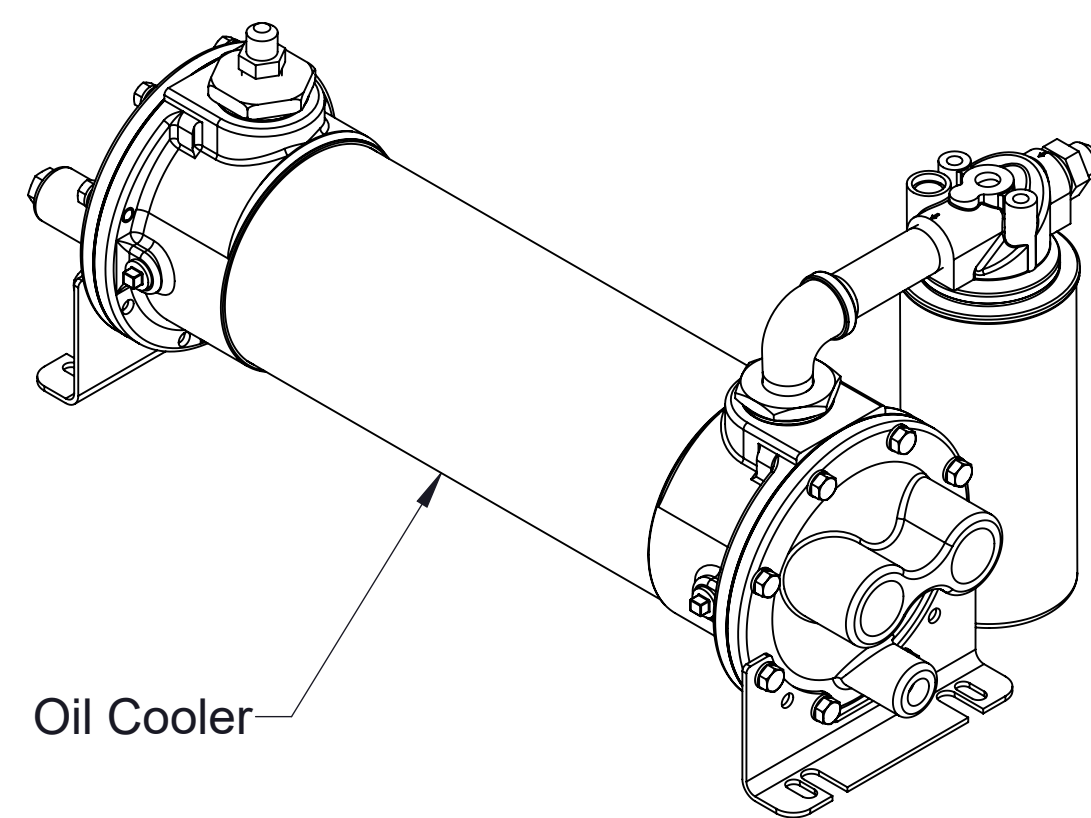
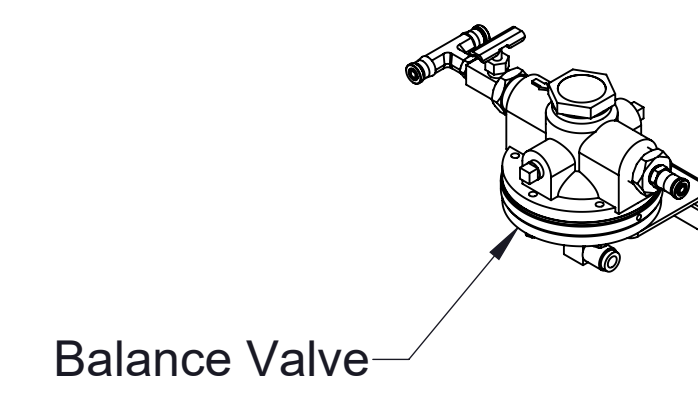
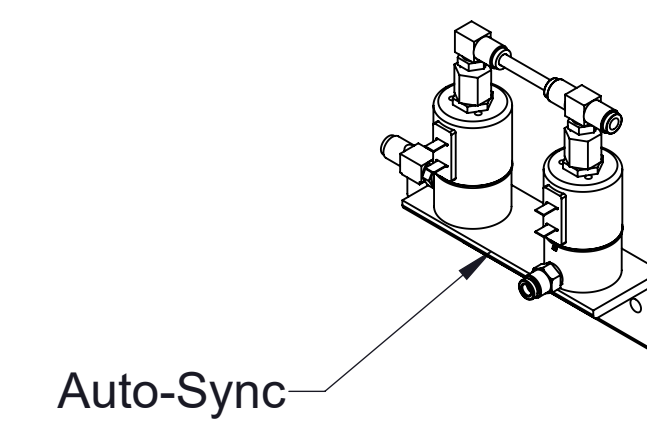
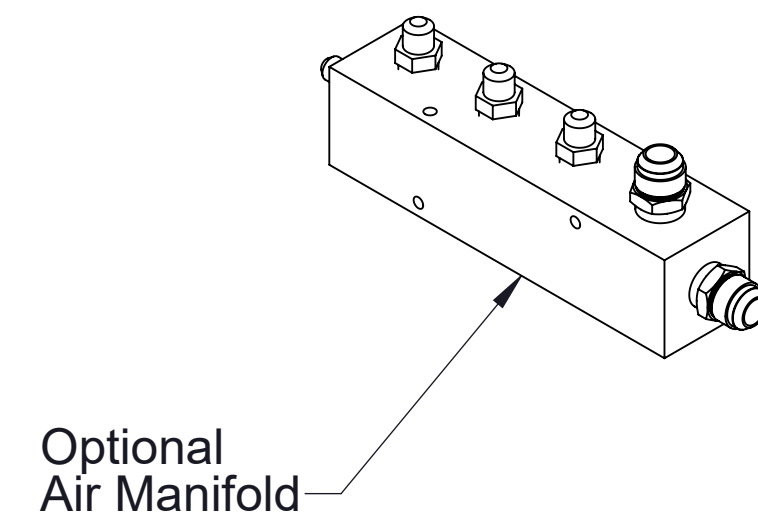
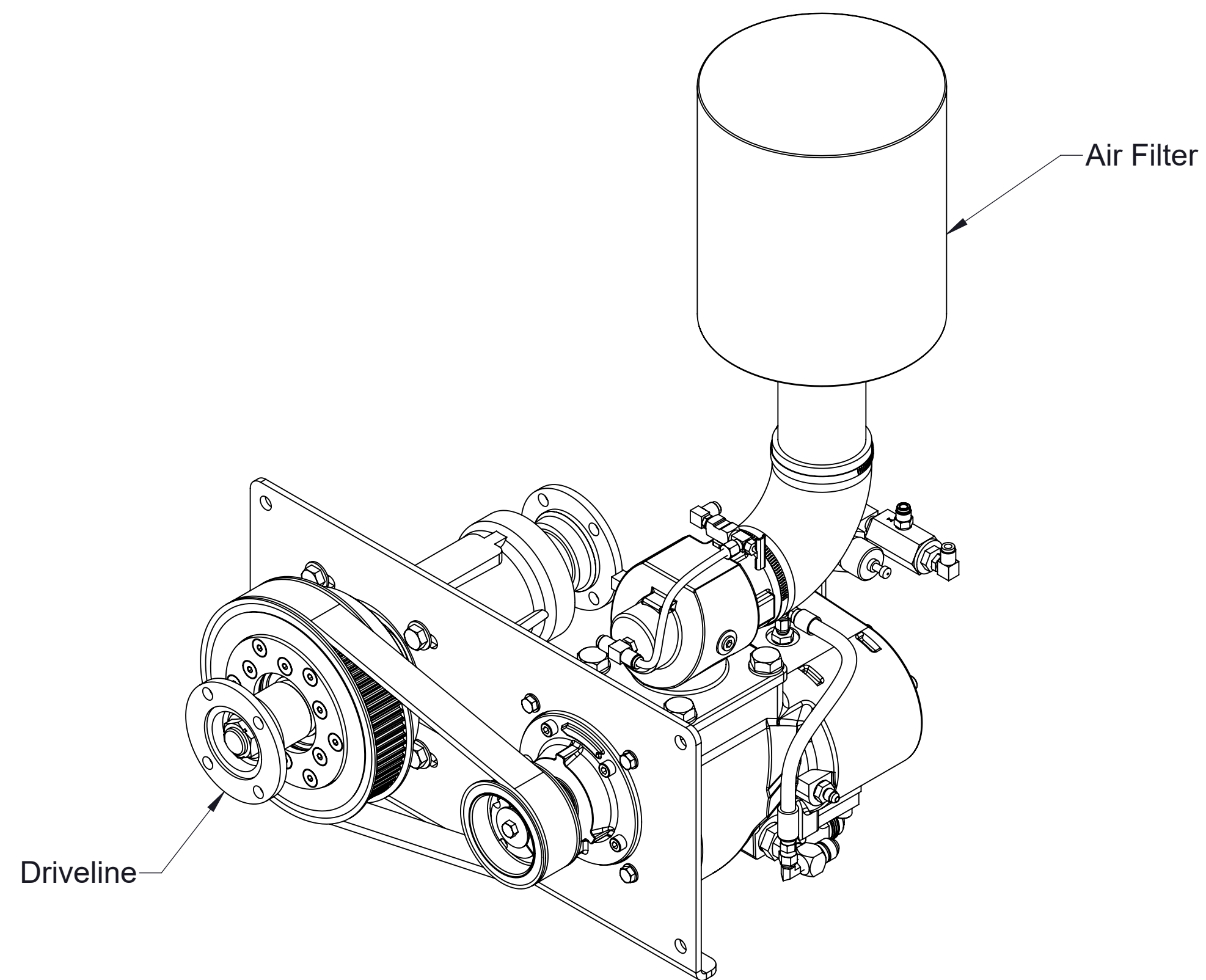

**AIR
PRESSURE
GAUGE**

Optional
Air Pressure
Gauge Kit

**HOSES
AND
FITTINGS**

Optional
Hose and
Fitting Kit

Index:

Component		Model		See Pages					
		Traditional CAFS	Generated CAFS		Compressor				Air Filter and Mounting Bracket
			One-Step	Eclipse GEN 2.0	Mounting	Driveline	Components	PMC Variations	
Compressor		100-B	100-OSB	100-ECLB	4	With Clutch 5 Without Clutch 6	7	8	9
Panel Components		All Models			10				
Schematic	Air	Traditional CAFS, Model 100-B			11				
		Generated CAFS Models 100-OSB, 100-ECLB		Without High Rise	12				
				With High Rise	13				
	Electrical	Traditional CAFS, Model 100-B			14				
		Generated CAFS, Models 100-OSB, 100-ECLB			See Foam Generator Service Parts List				
		Voltage Converter, 24V Systems Only (All Models)			15				
Auto-Sync		See Auto-Sync Service Parts List Traditional CAFS Model 100-B Generated CAFS with High Rise Option Only, Models 100-OSB, 100-ECLB							
Balance Valve		See Balance Valve Service Parts List, Traditional CAFS Model 100-B Only							
Oil Cooler		See Oil Cooler Service Parts List (All Models)							
Separator Filter		See Separator Filter Service Parts List (All Models)							
Sump		See Sump Service Parts List (All Models)							
Hydraulic Schematic		See Hose and Fitting Kit Service Parts List (All Models)							
Air Manifold		Optional from Waterous, may have been furnished by OEM. See the following Service Parts Lists: Air Manifold Air Discharge Kits Air Pressure Gauge ICS Valve Hose and Fitting Kits							
CAFS Discharge									
Air Pressure Gauge									
Hoses and Fittings									

Horizontal Drive

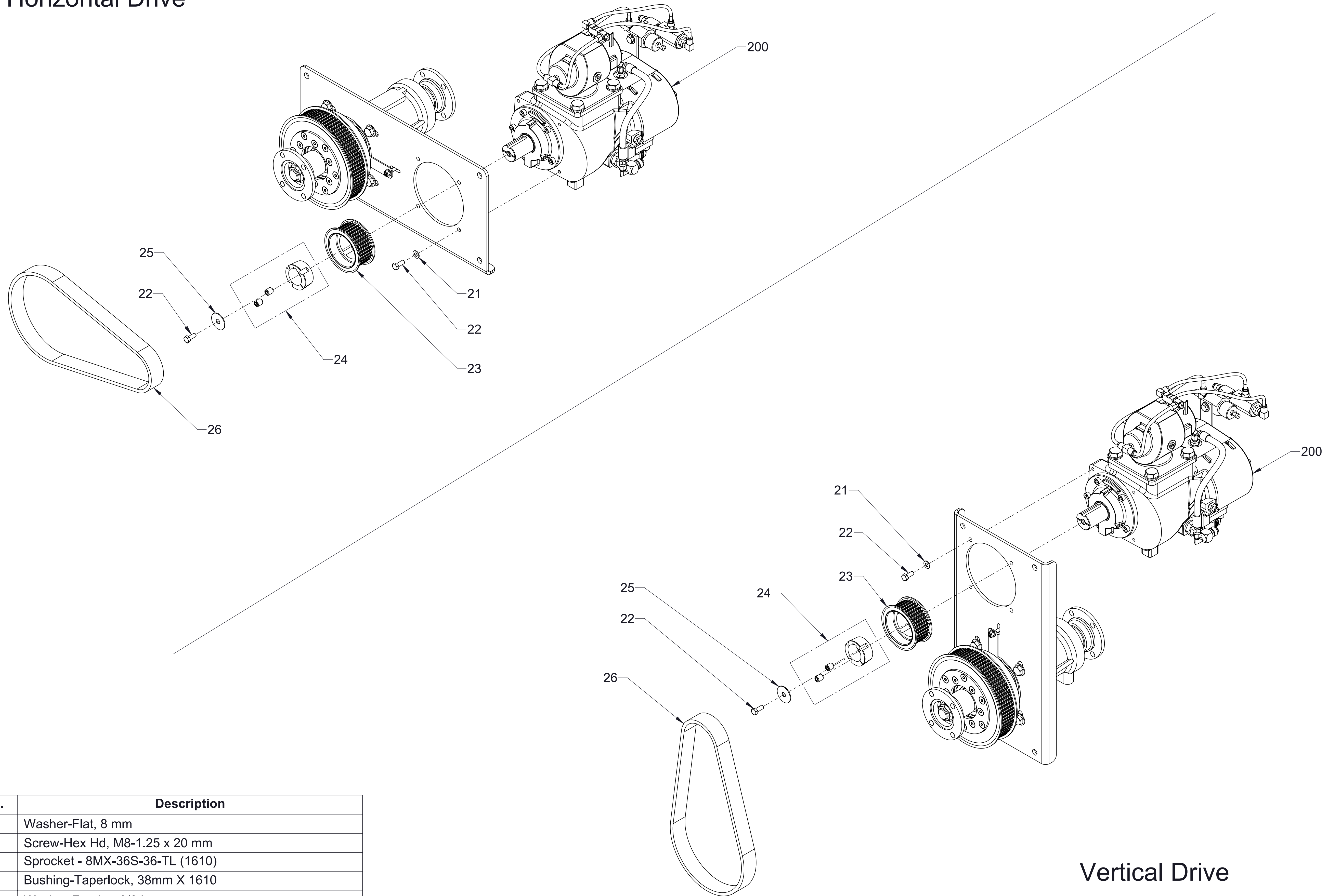

Ref No.	Description
21	Washer-Flat, 8 mm
22	Screw-Hex Hd, M8-1.25 x 20 mm
23	Sprocket - 8MX-36S-36-TL (1610)
24	Bushing-Taperlock, 38mm X 1610
25	Washer-Fender, 3/8 in
26	Belt-Poly Chain, 8MGT-1000-36
200	Compressor Subassembly

COMPRESSOR - MOUNTING

MODELS: 100-B, 100-OSB, 100-ECLB

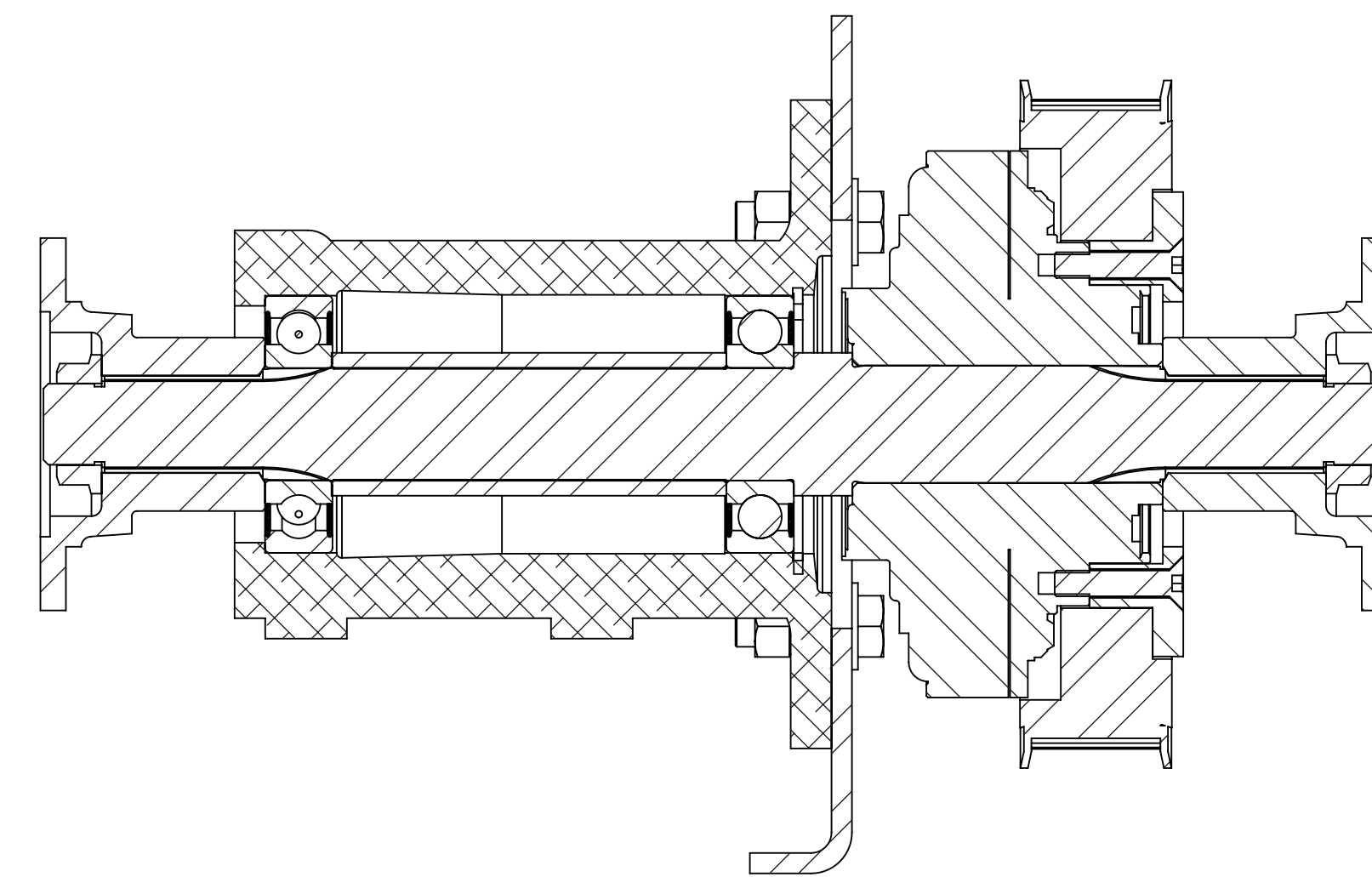
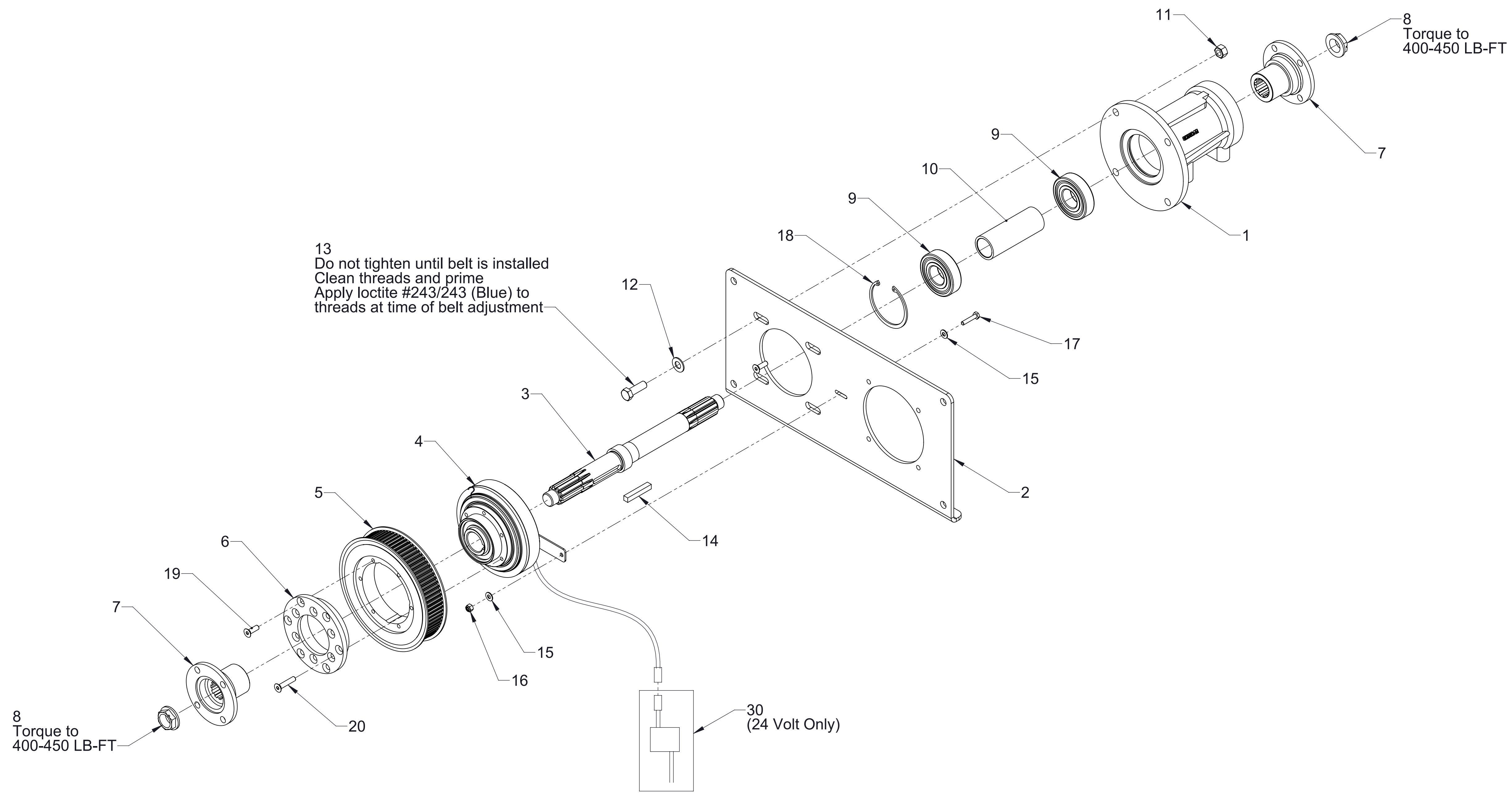

Cross-Section View

Ref No.	Description
1	Housing-Bearing
2	Bracket-Compressor Mounting
3	Input Shaft
4	Clutch
5	Drive Sprocket
6	Sprocket Adapter
7	Flange-Companion, Female
8	Nut-Self Locking, 1-20 UNEF-2B
9	Bearing, Ball, Single Row, Double Shield, 35 x 80 x 21 mm
10	Spacer-Bearing
11	Nut-Hex, 1/2-13
12	Washer-Plain, 1/2 in
13	Screw-Hex Hd, 1/2-13 x 1-1/2 in
14	Key-Square, 3/8 x 2-1/4 in
15	Washer-Plain, 1/4 in
16	Nut-Hex, Nylok, 1/4-20
17	Screw-Hex Hd, 1/4-20 x 1-1/4 in
18	Ring-Retaining, Internal, 3-5/32 in Bore Dia
19	Screw-Soc Countersunk Hd, M8-1.25 x 25 mm
20	Screw-Soc Countersunk Hd, M8-1.25 x 40 mm
30	Voltage Converter, 24 to 12 Volt, 10 amp

COMPRESSOR - DRIVELINE WITH CLUTCH

MODELS: 100-B, 100-OSB, 100-ECLB

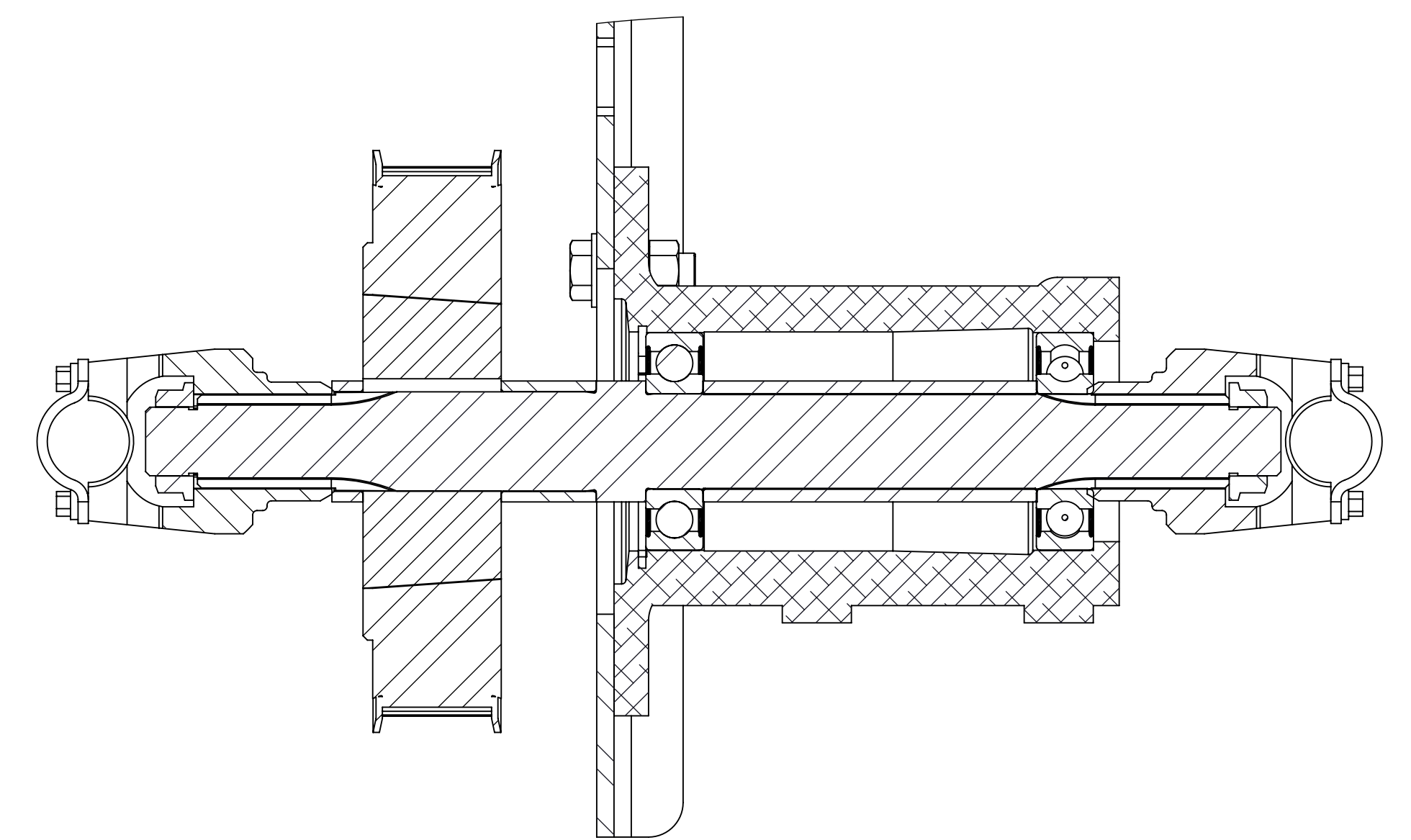
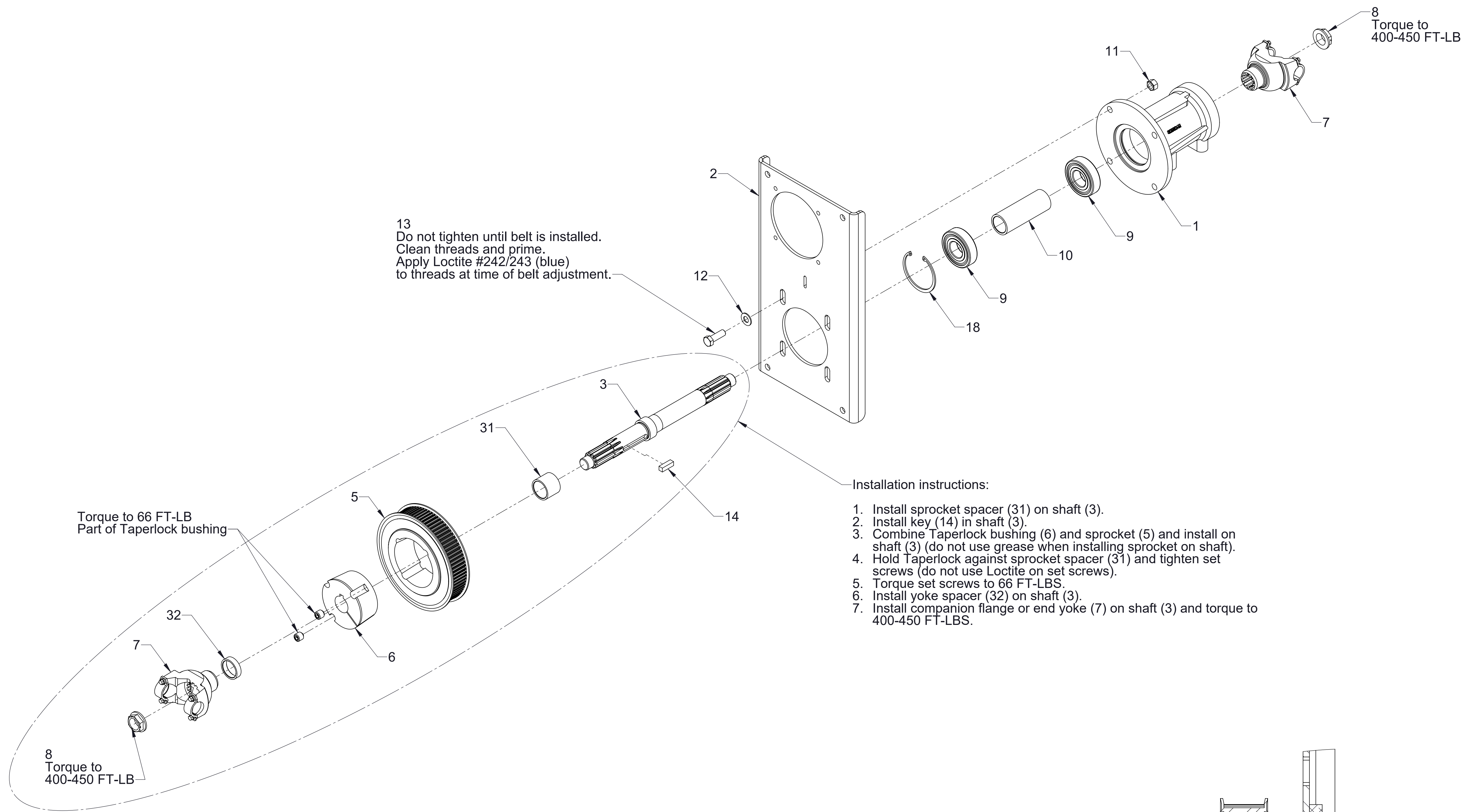

Cross-Section View

Ref No.	Description
1	Housing-Bearing
2	BRKT COMP MNT VERT 100-SB W/ CLUTCH
3	Shaft-Input
5	Sprocket, 8MX-80S-36
6	Bushing-Taperlock, 3020 x 1-7/16
7	End Yoke
8	Nut-Self Locking, 1-20 UNEF-2B
9	Bearing, Ball, Single Row, Double Shield, 35 x 80 x 21 mm
10	Spacer-Bearing
11	Nut-Hex, 1/2-13
12	Washer-Plain, 1/2 in
13	Screw-Hex Hd, 1/2-13 x 1-1/2 in
14	Key-Square, 3/8 x 1-1/4 in
18	Ring-Retaining, Internal, 3-5/32 in Bore Dia
31	Spacer-Sprocket
32	Spacer-Yoke

COMPRESSOR - DRIVELINE WITHOUT CLUTCH

MODEL: 100-B

Ref No.	Description
100	Plate-Serial
200	Compressor Assembly (Includes 201-238 and 900)
201	Inlet-Air, 2-1/2 X 90°
202	Bushing-Reducing, 1/4 MNPT x 1/8 FNPT
203	Tee - Branch, 1/8 MNPT x 1/8 FNPT X 1/8 FNPT
204	Valve - Trim, 1/8 MNPT X 1/4 Compression
205	Elbow - 90° 1/4 PTC X 1/8 MNPT
206	Elbow - 90°, 1/4 PTC X 1/4 MNPT
207	Tee - Branch, 1/4 MNPT X 1/4 PTC X 1/4 PTC
214	Adapter-Straight, 4 MJIC X 12 MM
217	Hose Assembly-Oil Injection
218	Body-Tee, Oil Return
222	Gasket-Outlet Flange
223	Oil Injection Fitting
224	Outlet Flange
226	Elbow - 90°, 1 MNPT X 16 MJIC
227	OS70 Compressor Bottom Outlet
228	Red Air Brake, 1/4 in. x 24 in.
229	Blue Air Brake, 1/4 in. x 24 in.
230	Green Air Brake, 1/4 in. x 24 in.
231	Compressor Replacement Kit
232	O-Ring, 3-7/8 X 4-1/4 in
235	Screw-Hex Hd, M16-2 x 30 mm
237	Washer-Flat, 8 mm
238	Washer-Flat, 16 mm
246	Screw-Soc Hd, M10-1.5 x 25 mm
247	Shaft Seal Repair Kit
900	PMC Assembly

200
Compressor Subassembly
(includes 201-246 and 900)

228-Red Tubing
229-Blue Tubing
230-Green Tubing
(See Air Schematic)

247
Shaft Seal Repair Kit

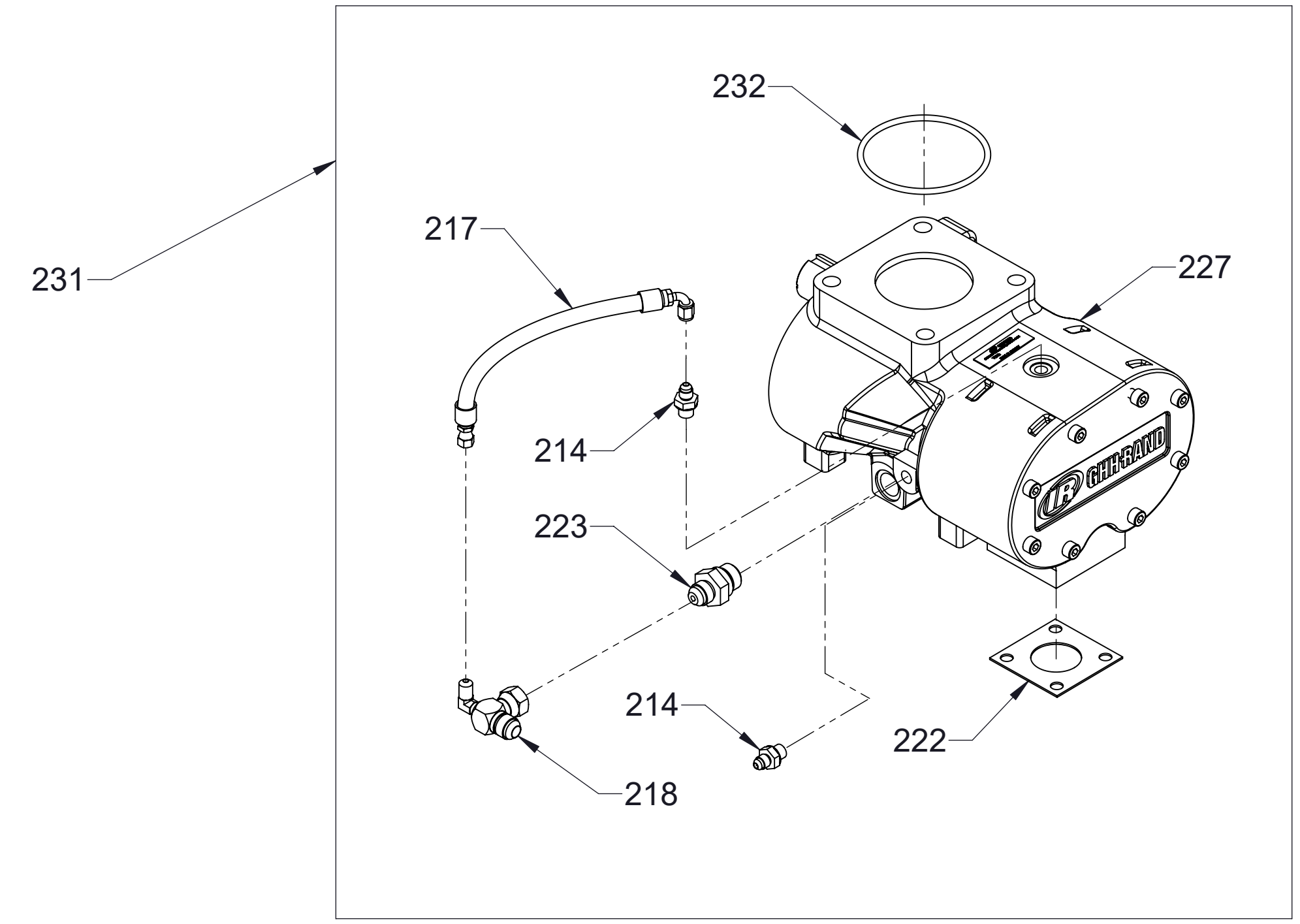
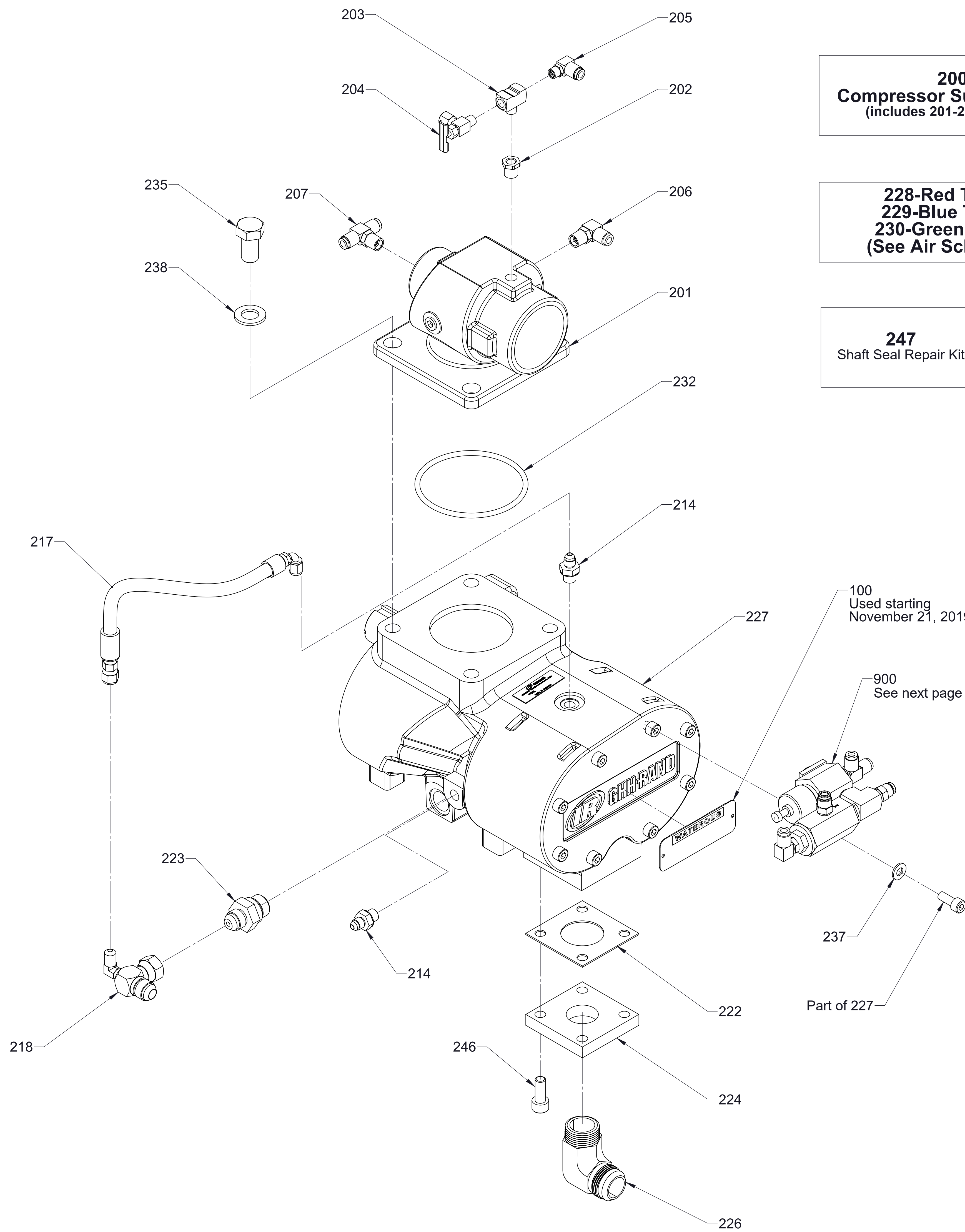

COMPRESSOR - COMPONENTS
MODELS: 100-B, 100-OSB, 1000-ECLB

Ref No.	Description
900	PMC Assembly (Includes 901-914)
901	Pressure Regulator Aircon
902	Blowdown Valve Aircon
903	Bracket
904	Adapter - Straight, 1/4 MNPT X 1/4 AB
905	Elbow - 90°, 1/4 PTC X 1/4 MNPT
907	Tee-Branch, 1/4 AB x 1/4 MNPT x 1/4 AB
908	Washer-Plain, 3/8 in
909	Screw-Hex Hd, 3/8-16 x 1/2 in
910	Valve-Solenoid
911	Nipple-Pipe, 1/4 NPT x 7/8 in
912	Tee-Standard, Pipe, 1/4 NPT
914	Tee-Street, 1/4 NPT

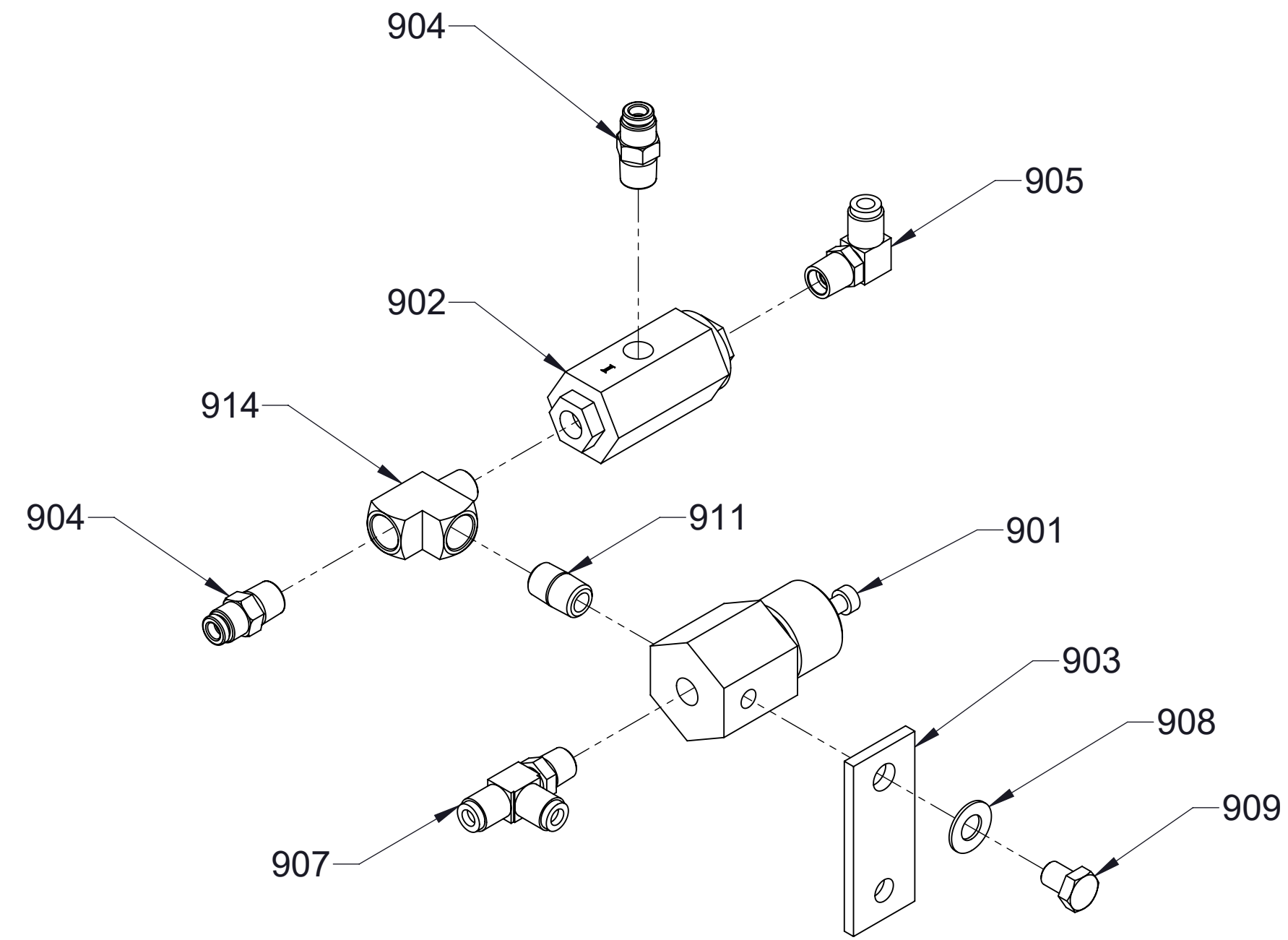

Traditional CAFS, Models 100-B

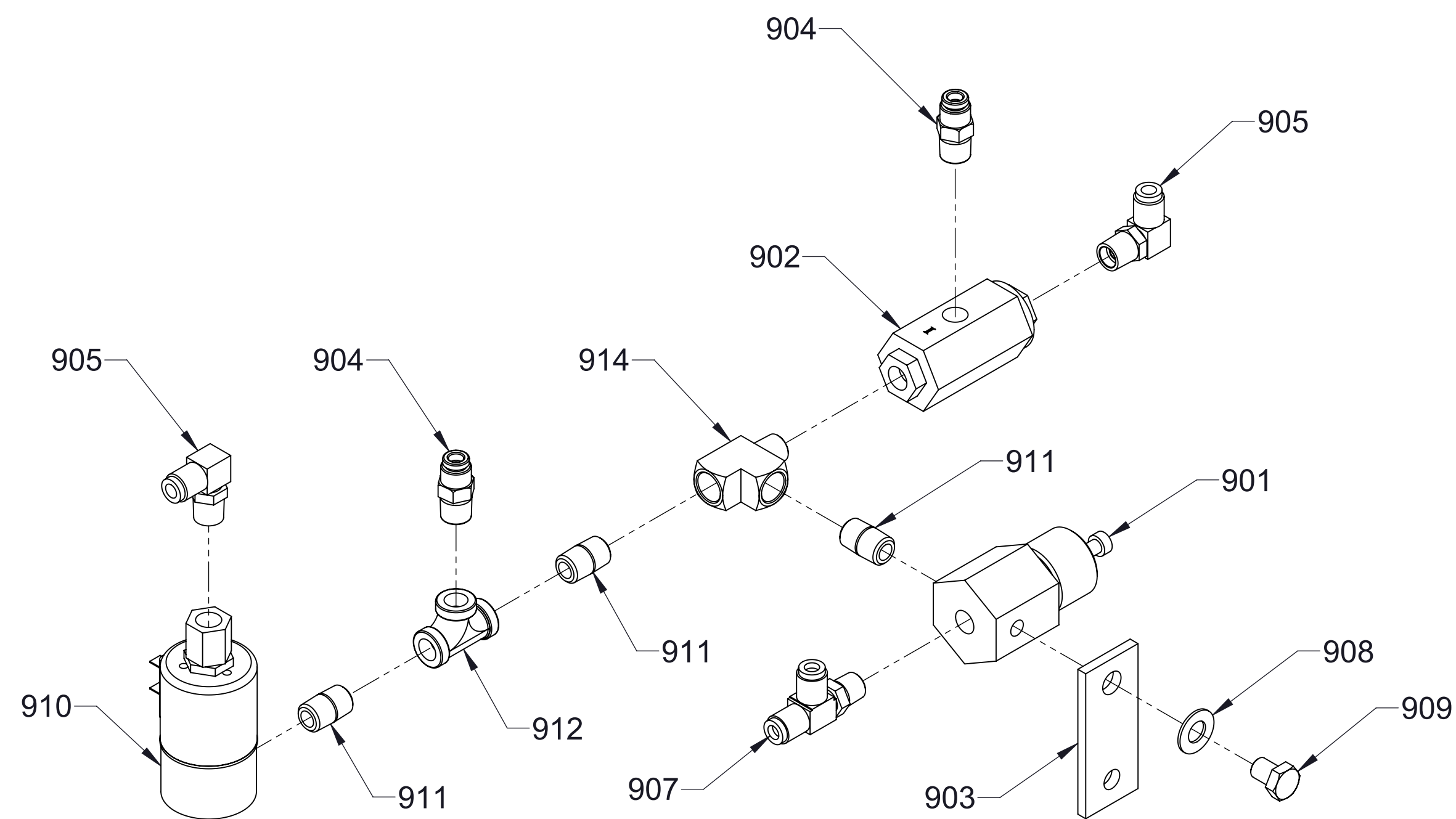

Without High Rise Option

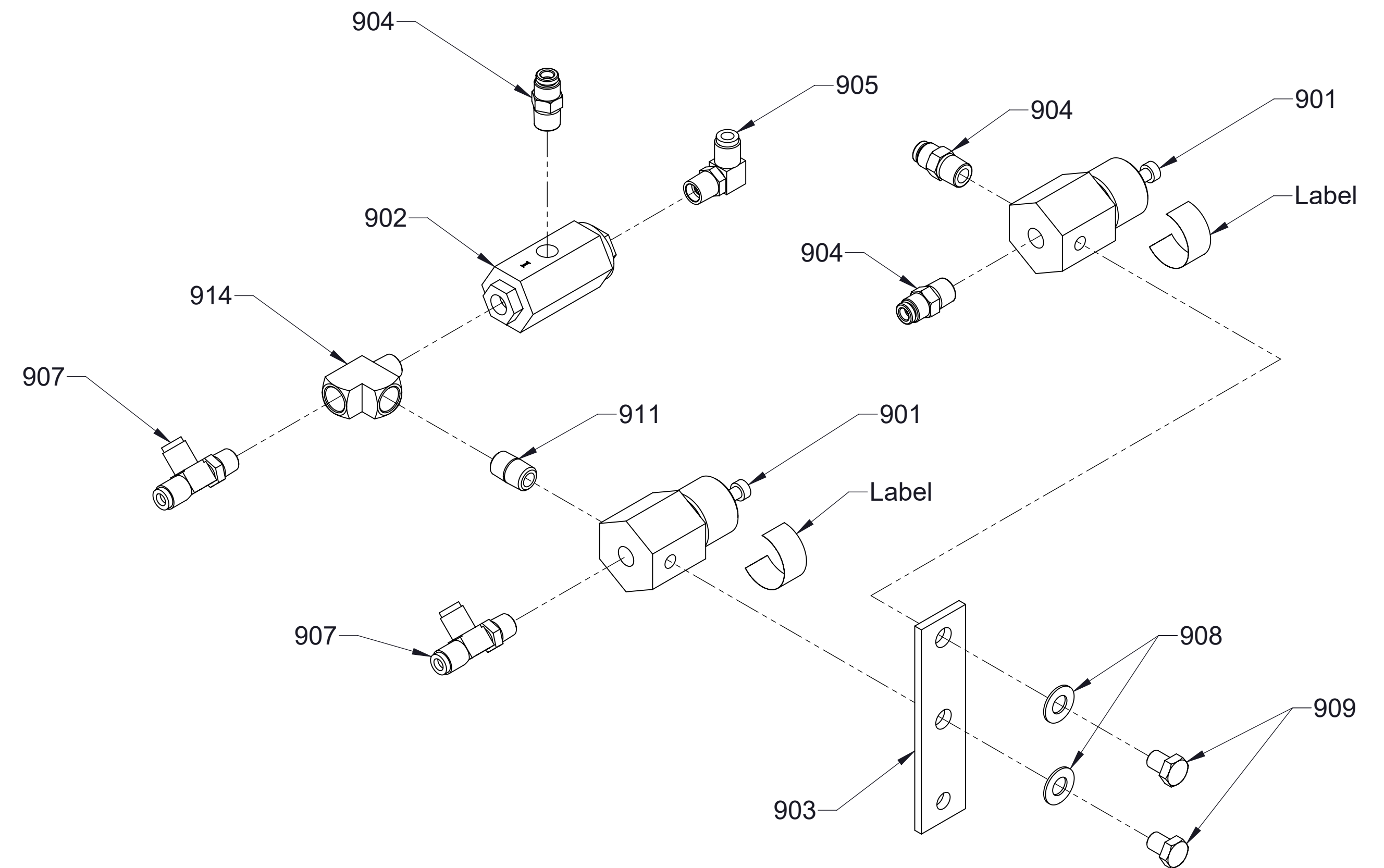

With High Rise Option

One-Step CAFS, Model 100-OSB
Eclipse GEN 2.0 CAFS, Model 100-ECLB

COMPRESSOR - PMC VARIATIONS

MODELS 100-B, 100-OSB, 100-ECLB

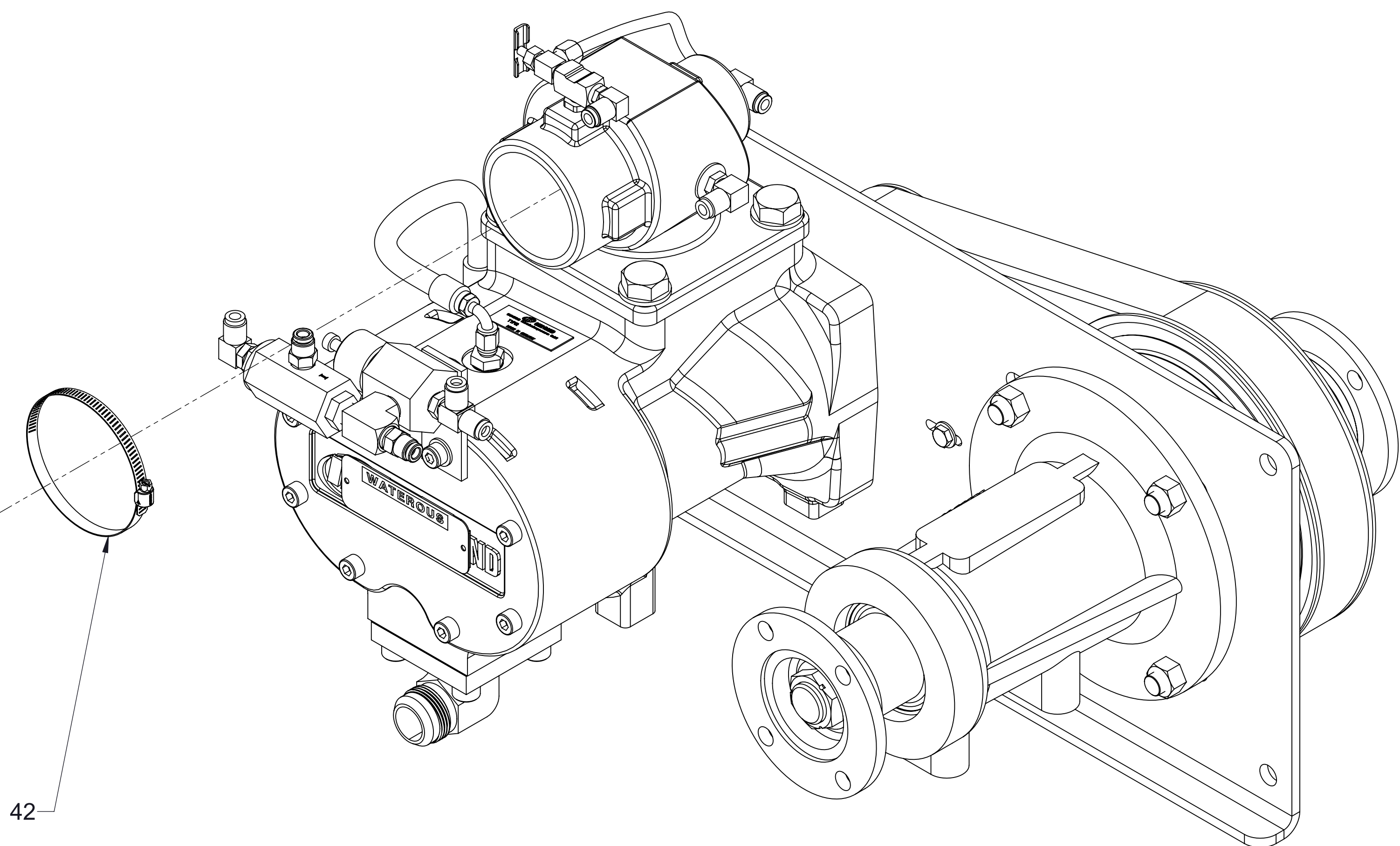
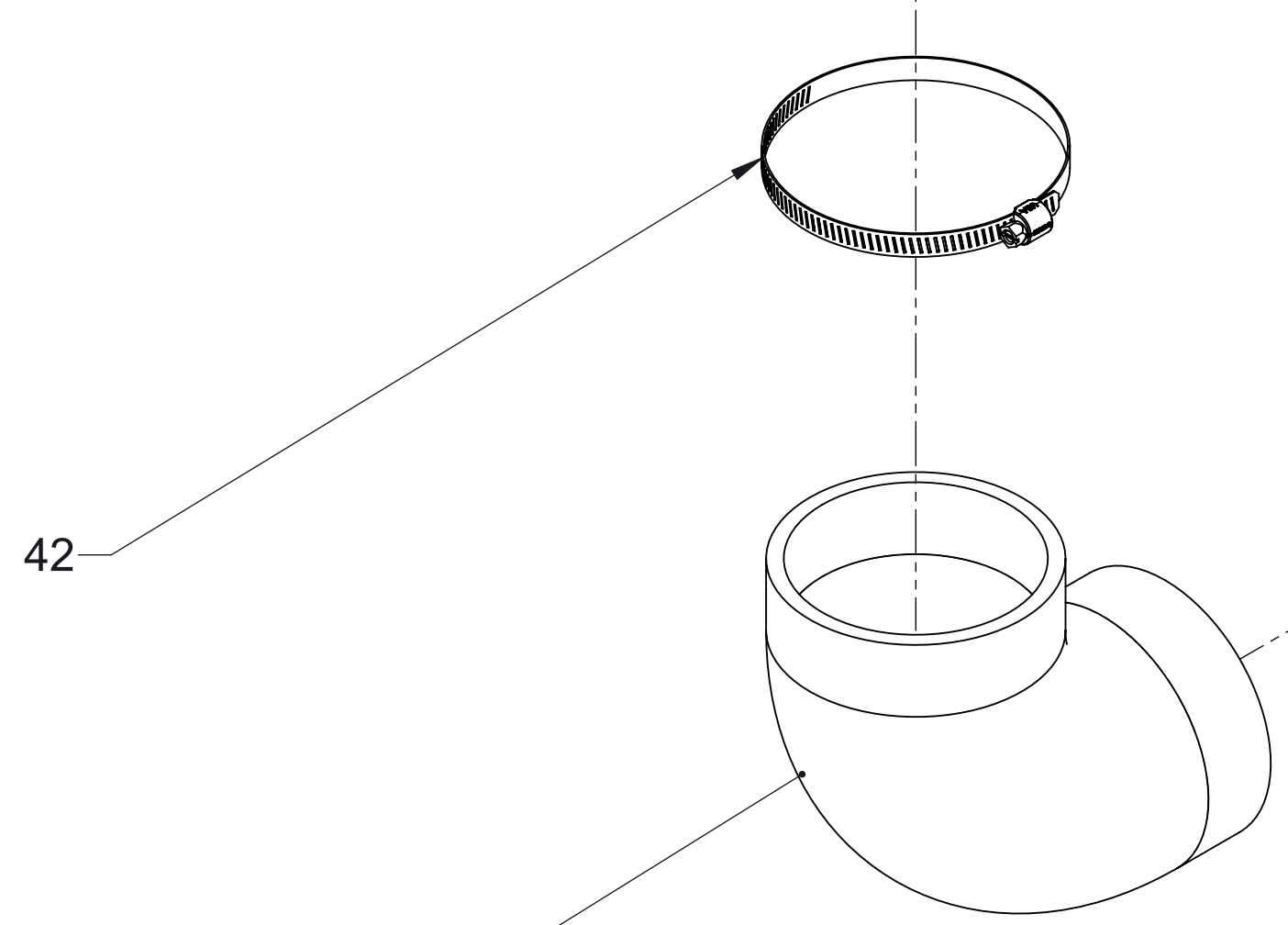
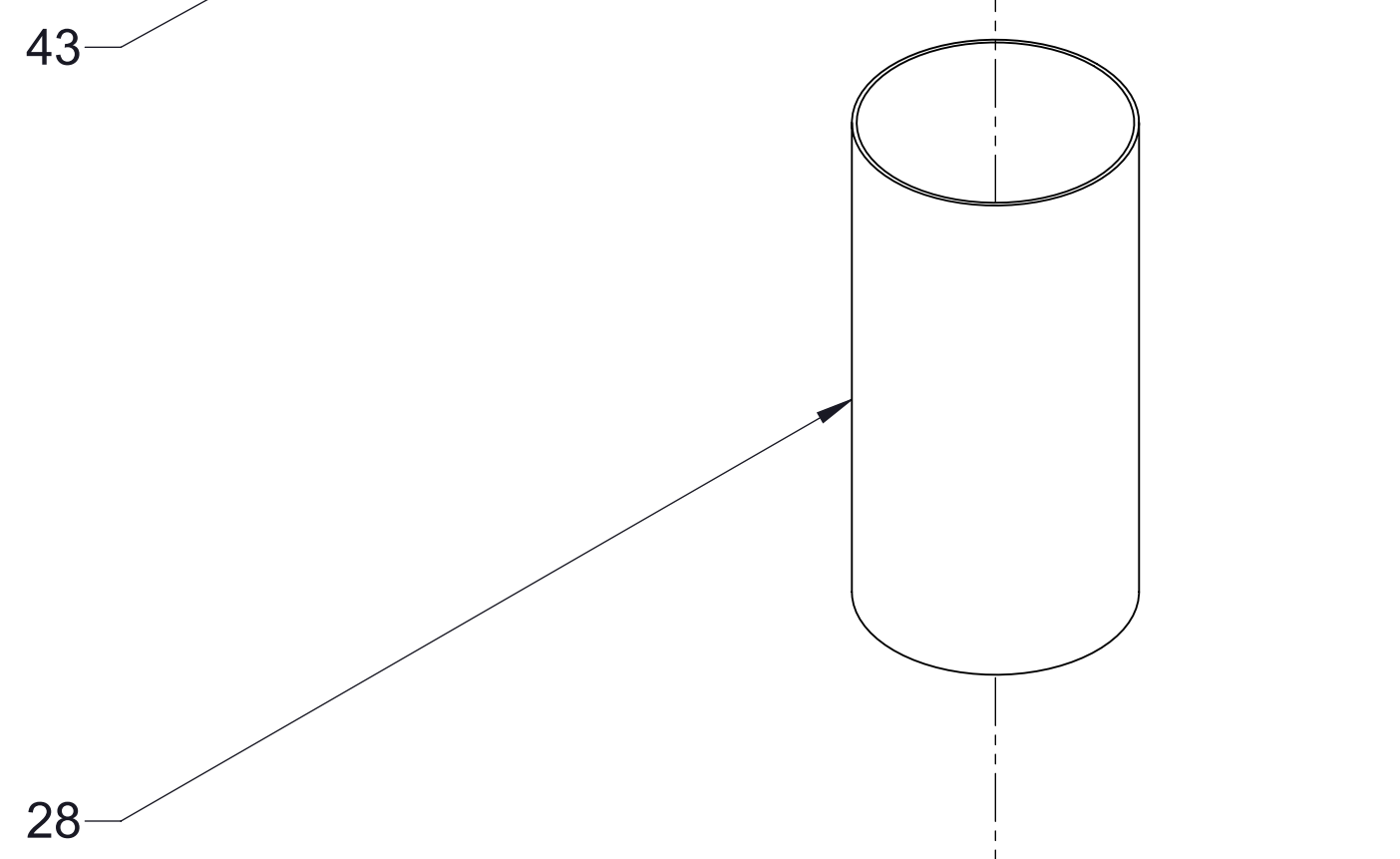
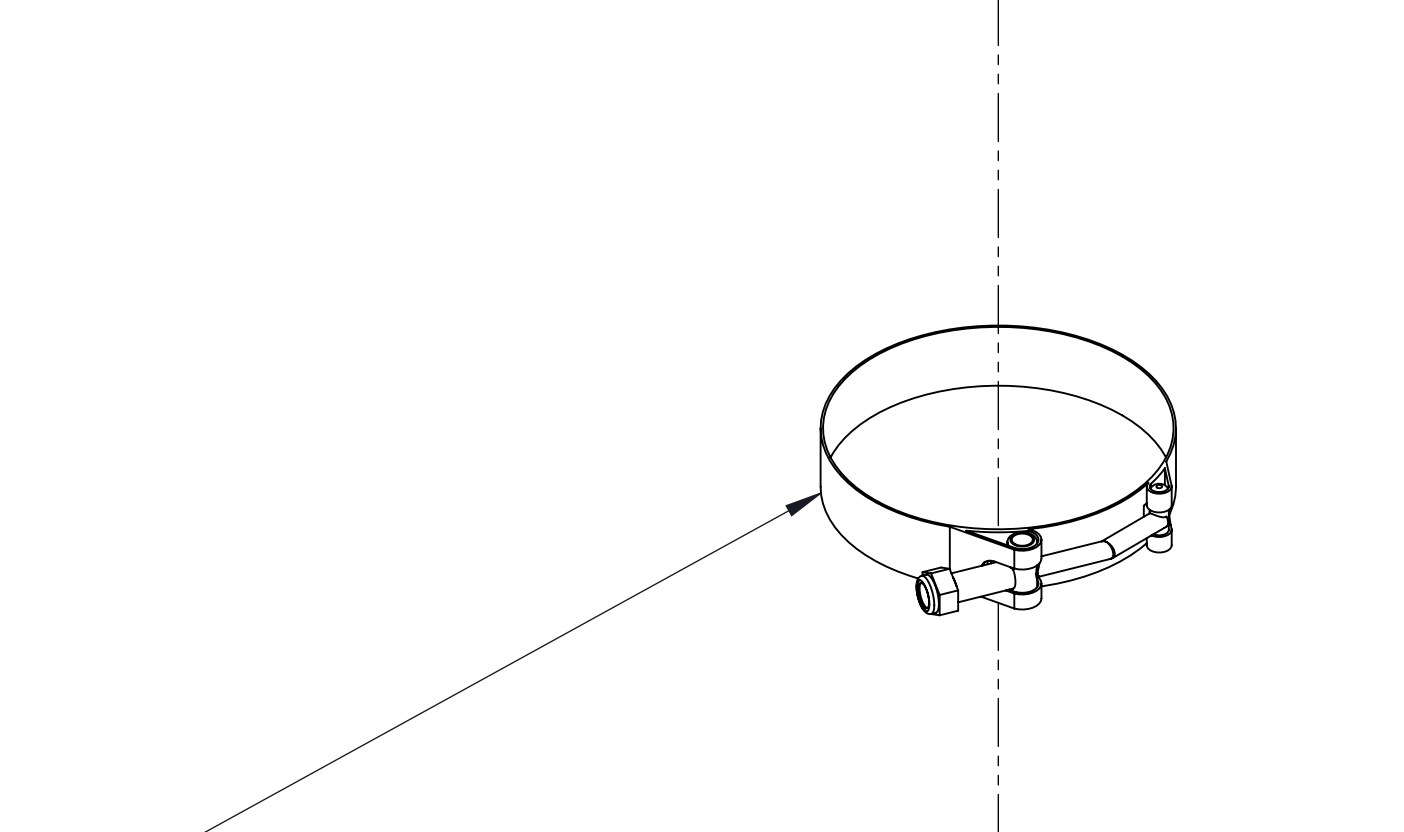
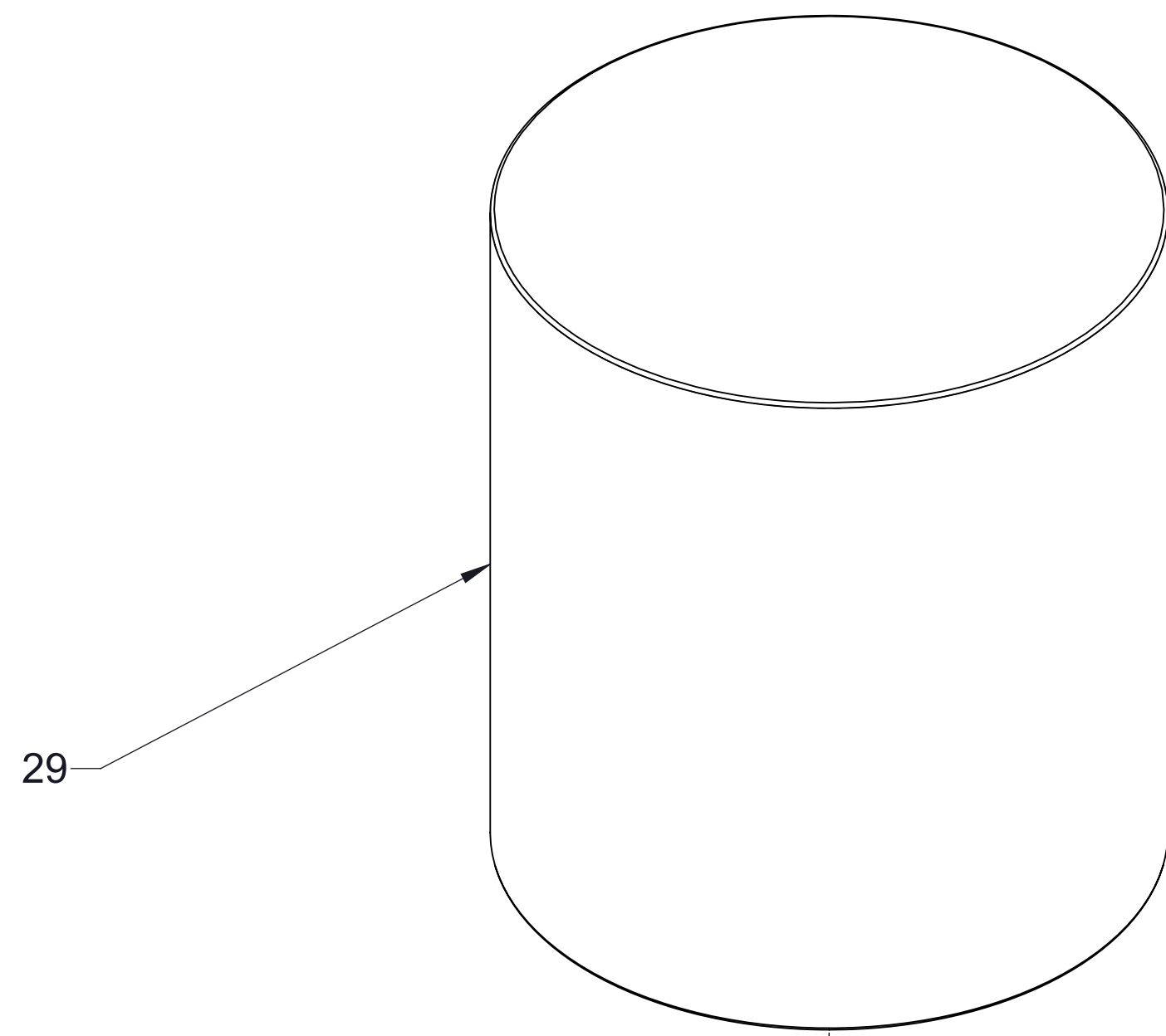

Ref No.	Description
28	Tube-Inlet Air 3 in x 48 in
29	Filter - Air, 3 in (CO85004)
42	Clamp-Hose 3-1/2 in
43	T-Bolt 3-1/2 in
44	Elbow - Rubber, 3 in x 90°

COMPRESSOR - AIR FILTER

NOTE: BASED ON INSTALLATION, CONFIGURATION MAY VARY FROM DIAGRAM

Ref No.	Description
45	Dual Scale Oil Temperature Gauge
46	Oil Temp Gauge to 24V Conversion Kit
60	Compressed Air Warning Plate
61	Hose Length Plate
100	Plate-Serial
325	Plate-Electric Auto-Sync
326	Harness-Switch, Electric Auto-Sync

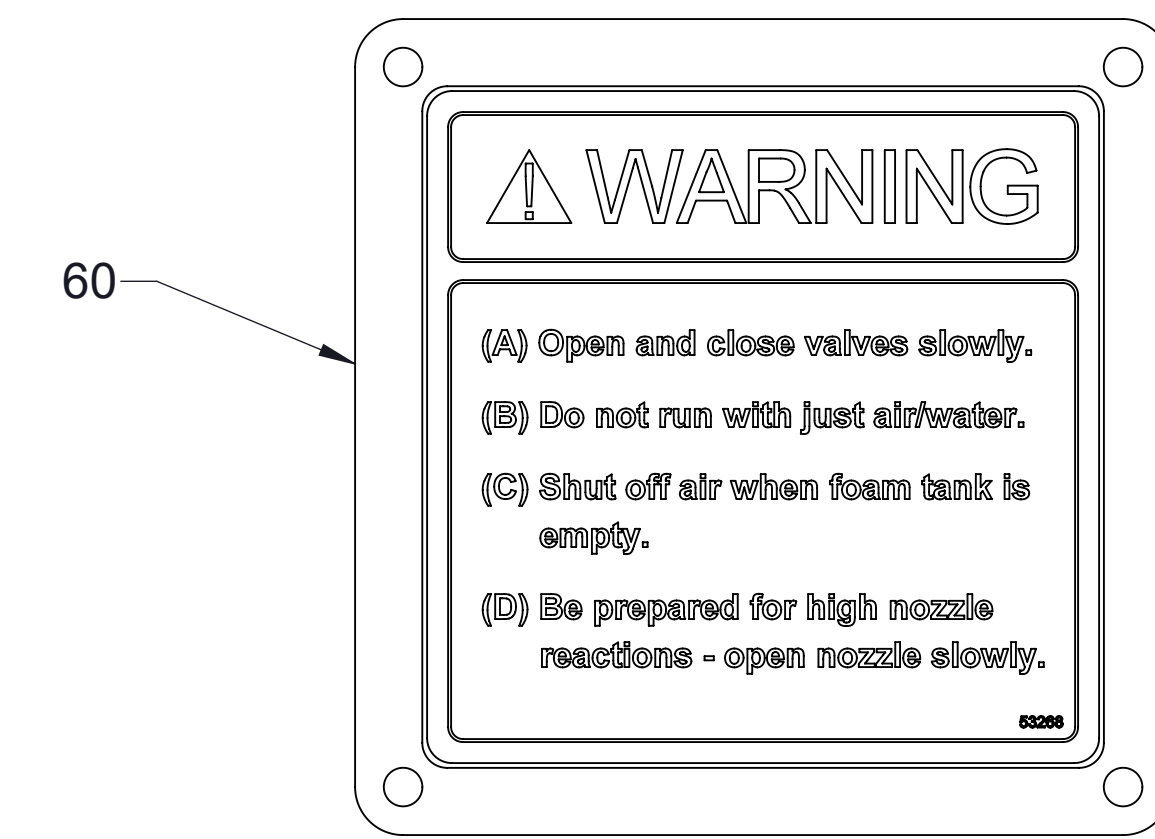
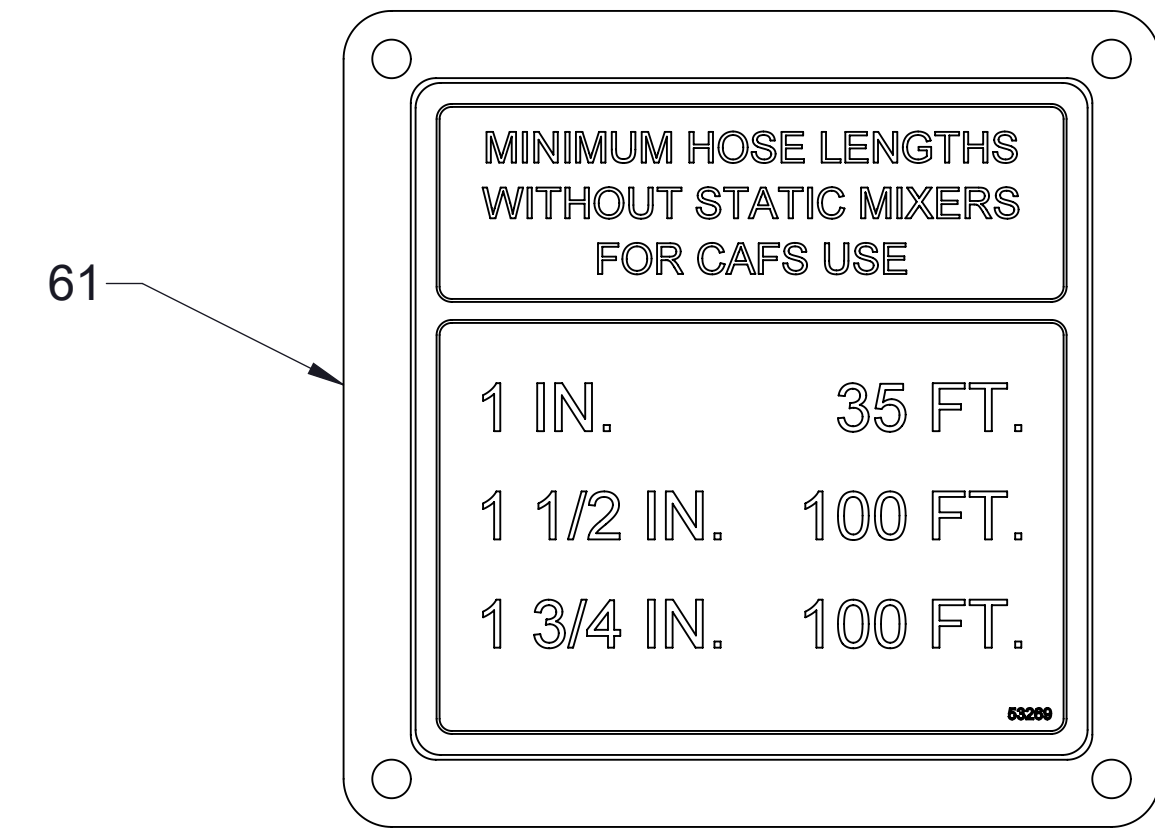
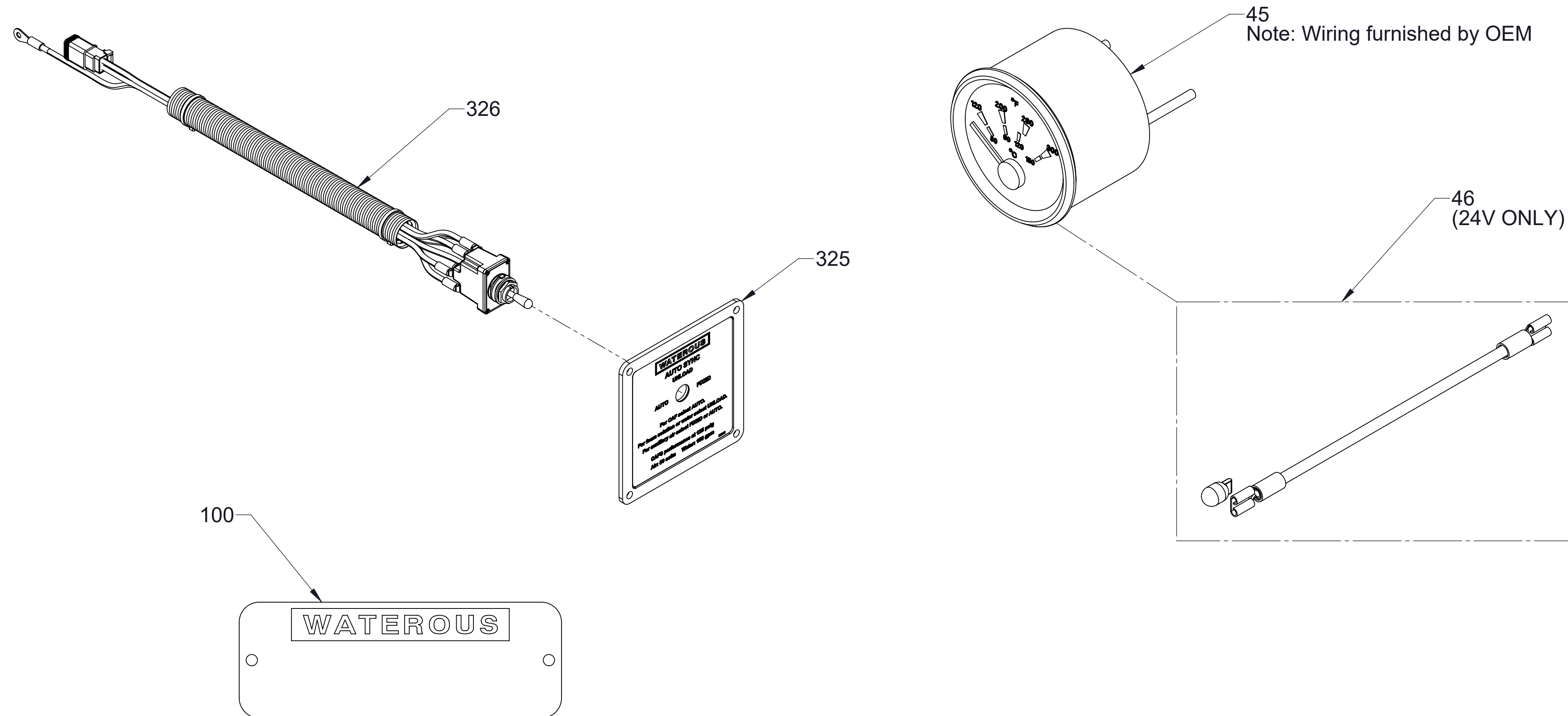

TRADITIONAL CAFS

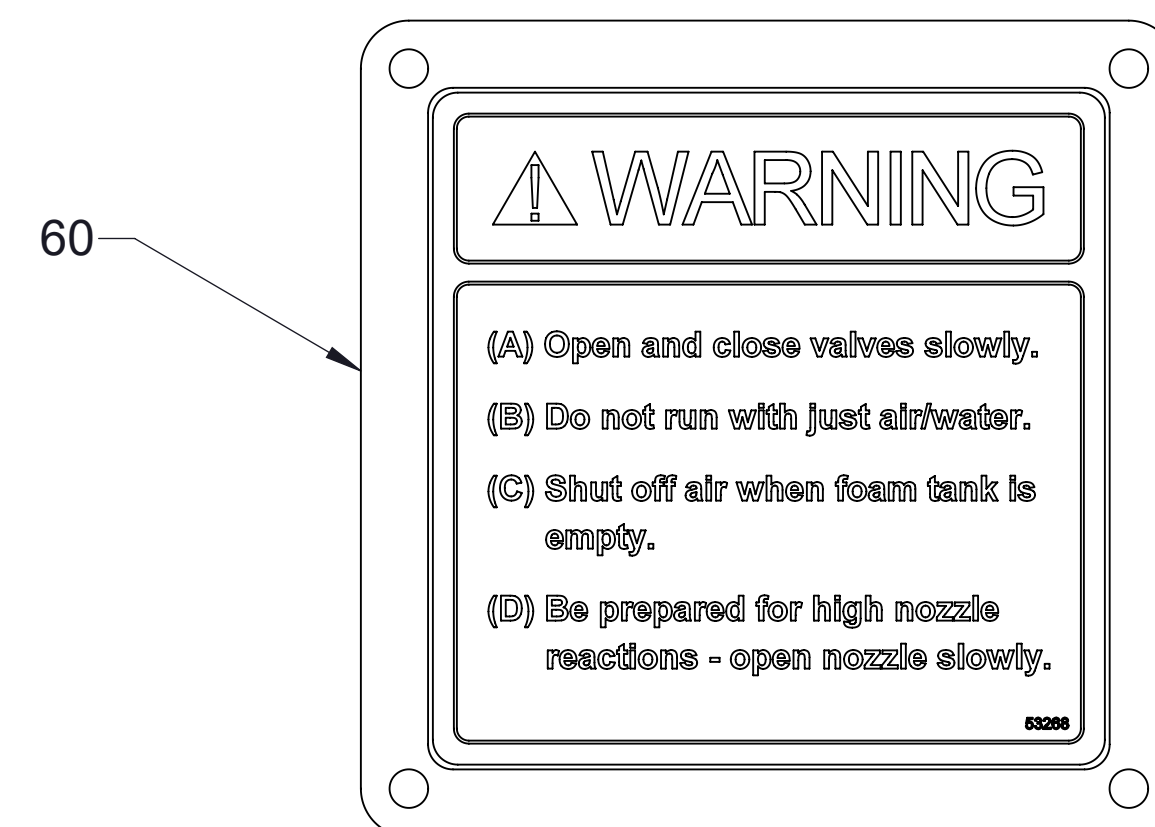
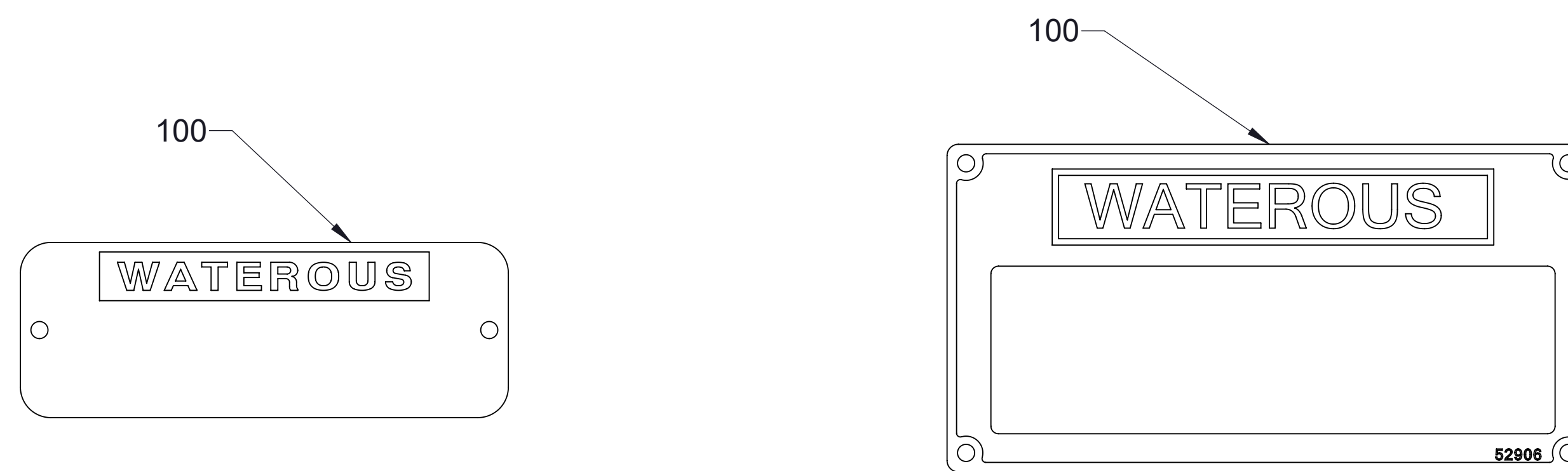

GENERATED CAFS, ONE-STEP AND ECLIPSE GEN 2.0 CAFS

PANEL COMPONENT

Ref No.	Description
63	Black Tube-Air Brake, 1/4 in. x 180 in. (Cut to suit application)
64	Red Tube-Air Brake, 1/4 in. x 120 in. (Cut to suit application)
65	Yellow Tube-Air Brake, 1/4 in. x 120 in. (Cut to suit application)
228	Red Tube-Air Brake, 1/4 in. x 24 in. (Cut to suit application)
229	Blue Tube-Air Brake, 1/4 in. x 24 in. (Cut to suit application)
230	Green Tube-Air Brake, 1/4 in. x 24 in. (Cut to suit application)

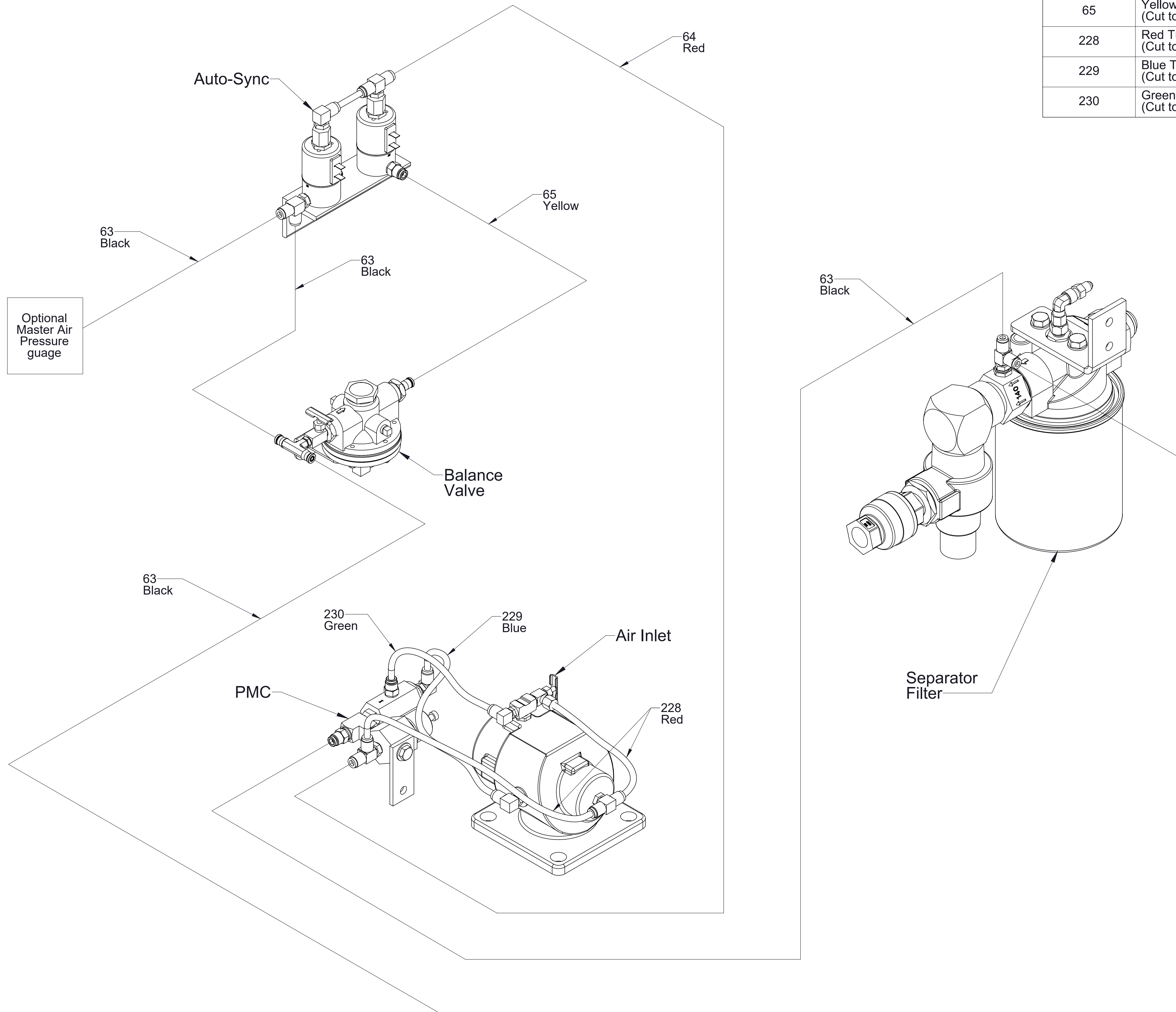

SCHEMATIC - AIR

MODEL: 100-B

Ref No.	Description
63	Black Tube-Air Brake, 1/4 in. x 180 in. (Cut to suit application)
228	Red Tube-Air Brake, 1/4 in. x 24 in. (Cut to suit application)
229	Blue Tube-Air Brake, 1/4 in. x 24 in. (Cut to suit application)
230	Green Tube-Air Brake, 1/4 in. x 24 in. (Cut to suit application)

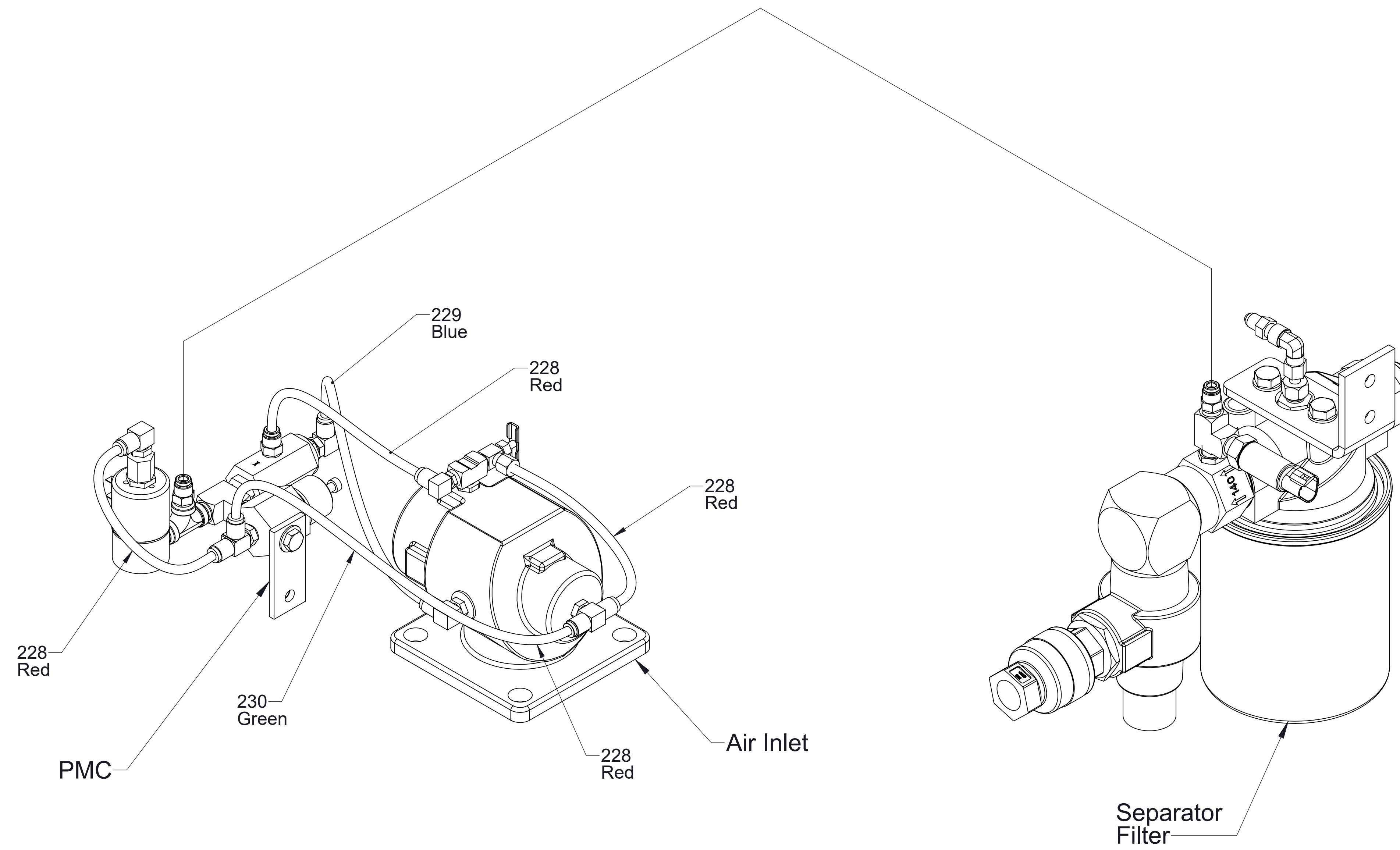

SCHEMATIC - AIR
 GENERATED CAFS
 MODELS 100-OSB, 100-ECLB
 WITHOUT HIGH RISE OPTION

Ref No.	Description
63	Black Tube-Air Brake, 1/4 in. x 180 in. (Cut to suit application)
64	Red Tube-Air Brake, 1/4 in. x 120 in. (Cut to suit application)
65	Yellow Tube-Air Brake, 1/4 in. x 120 in. (Cut to suit application)
228	Red Tube-Air Brake, 1/4 in. x 24 in. (Cut to suit application)
229	Blue Tube-Air Brake, 1/4 in. x 24 in. (Cut to suit application)
230	Green Tube-Air Brake, 1/4 in. x 24 in. (Cut to suit application)

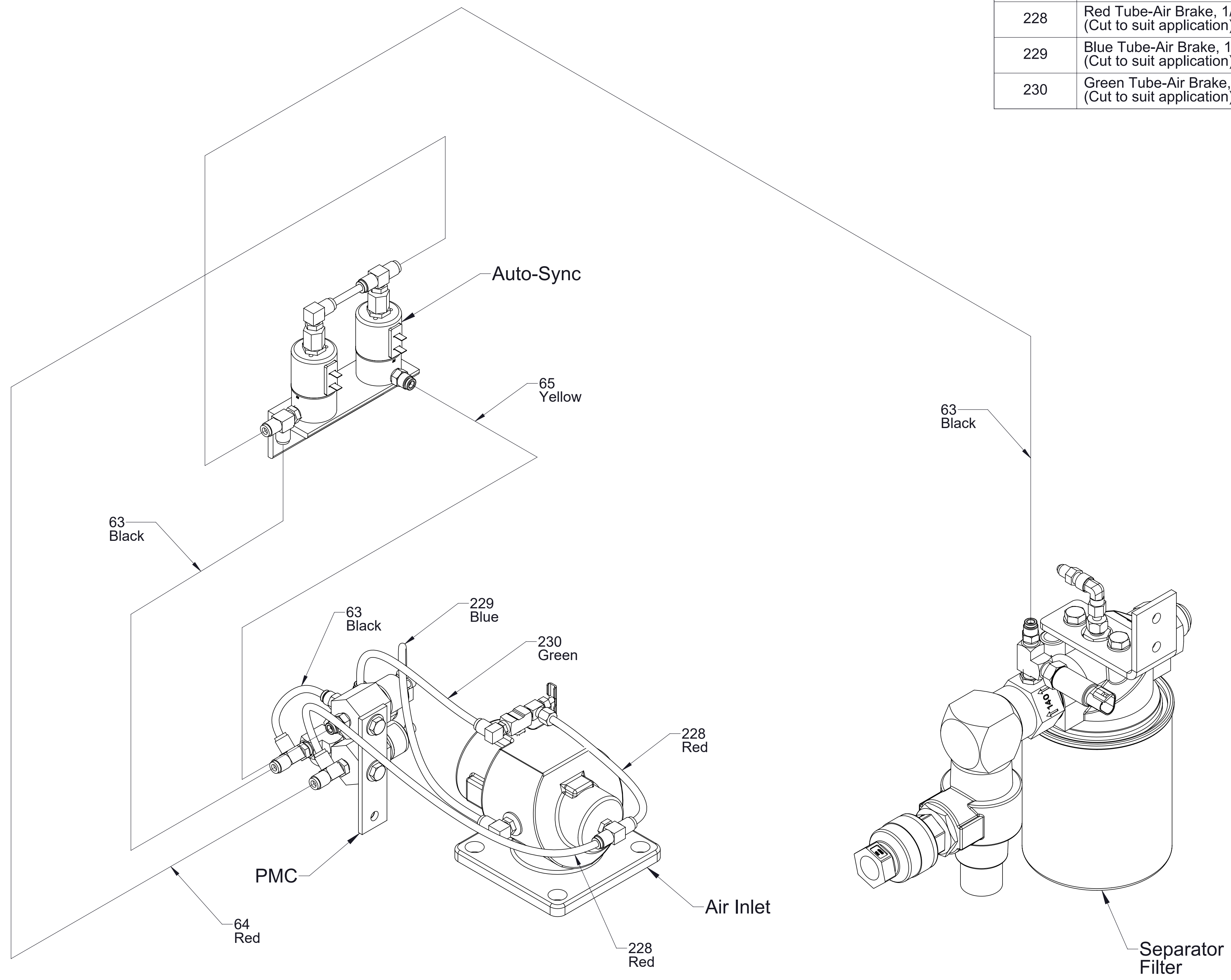

SCHEMATIC - AIR
 GENERATED CAFS
 MODELS 100-OSB, 100-ECLB
 WITH HIGH RISE OPTION

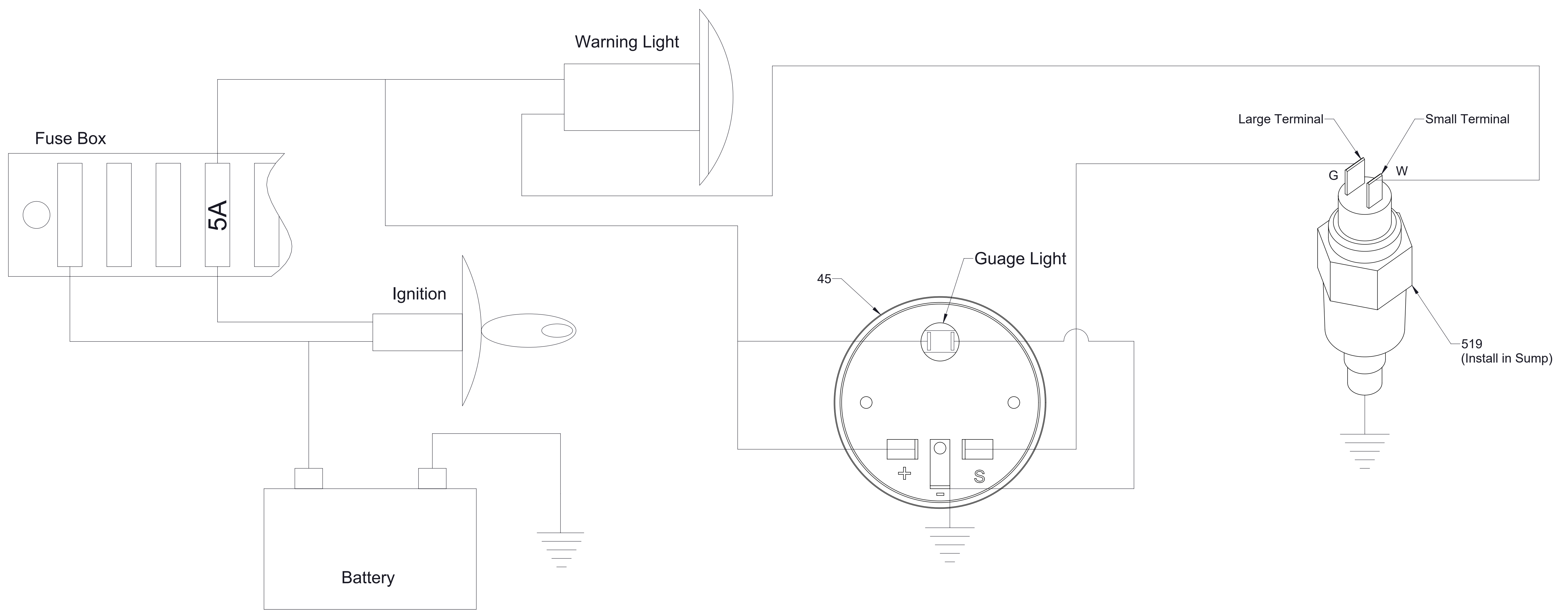

Note: Typical installation, all wiring, warning light, fuse, ignition switch and battery furnished by OEM

SUMP TEMPERATURE SENDER AND OIL TEMPERATURE GAUGE

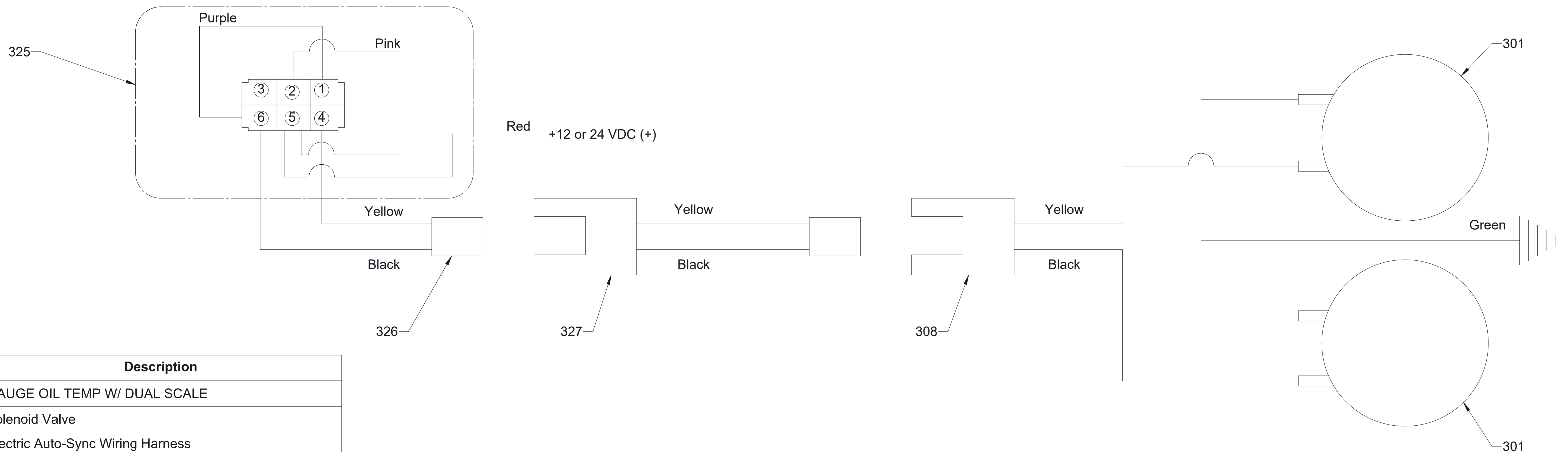

Ref No.	Description
45	GAUGE OIL TEMP W/ DUAL SCALE
301	Solenoid Valve
308	Electric Auto-Sync Wiring Harness
325	Electric Auto-Sync Plate
326	Electric Auto-Sync Switch Harness
327	Harness-Extension, Auto-Sync, 15 Feet
519	TEMP SENDER VDO 323-010

AUTO-SYNC PANEL AND SOLENOIDS

SCHEMATIC - ELECTRICAL

TRADITIONAL CAFS
FOR GENERATED CAFS SEE FOAM GENERATOR SERVICE PARTS LIST

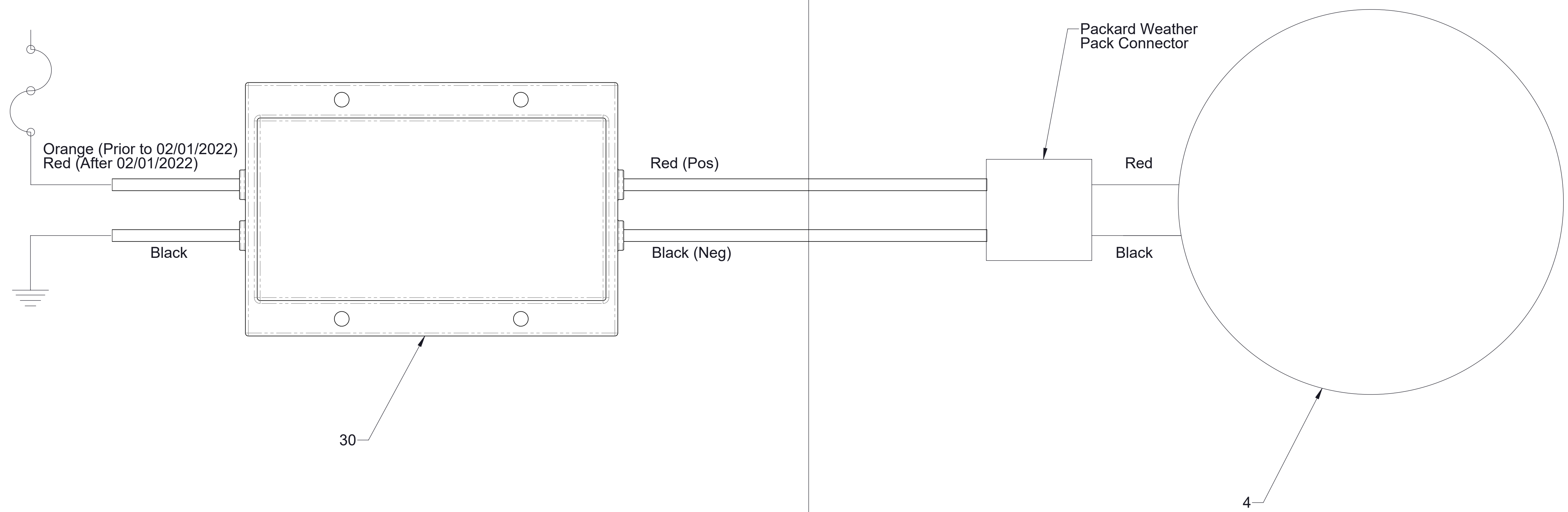

24 TO 12 CONVERTER REQUIRED FOR 24 VOLT SYSTEM

12 VOLT CLUTCH

Ref No.	Description
4	Clutch
30	Converter, 24/12 Volt, 10 Amp Output

SCHEMATIC - ELECTRICAL
 VOLTAGE CONVERTER
 (24 VOLT SYSTEMS ONLY)