

## Technical Bulletin No. 133

## K and T Series Transmission Update

Beginning February 1, 2020, orders for the K and T Series Transmission will ship with the new aluminum case configuration. The iron case configuration will no longer be available. See the major changes and listed below. **Note: All the internal components are compatible between the iron and aluminum transmission cases.**

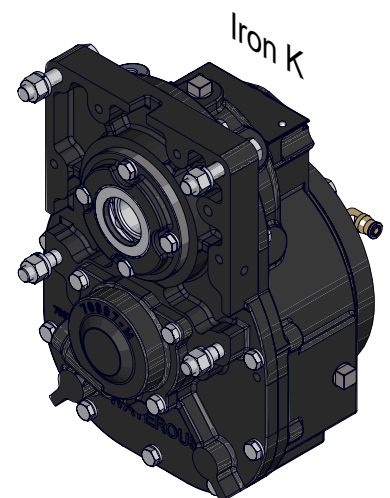
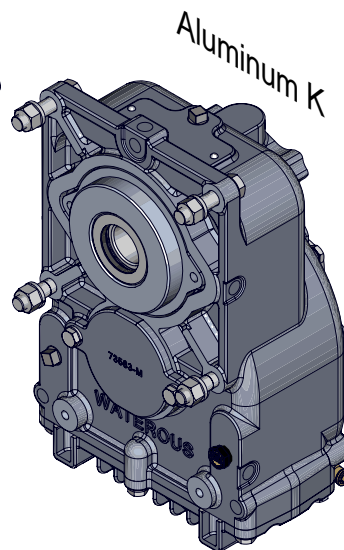
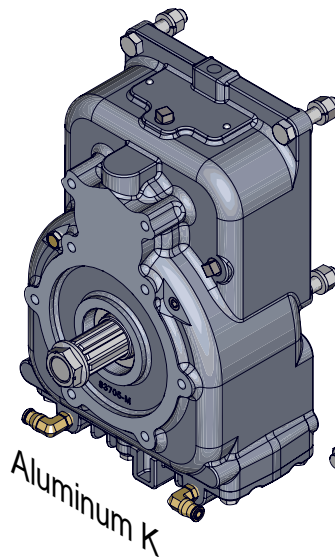
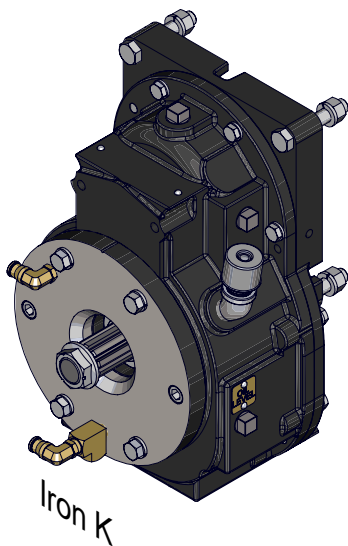

### Major Changes Include

- Case material changed from iron to aluminum
- Overall weight reduced by 50% (47 lb, 21 kg)
- One piece case with oil pan

### Additional Changes

- O-ring seal between case and oil pan
- Improved air cooling
- Improved water cooling, if required by your application

## Aluminum K-Transmission Dimensions

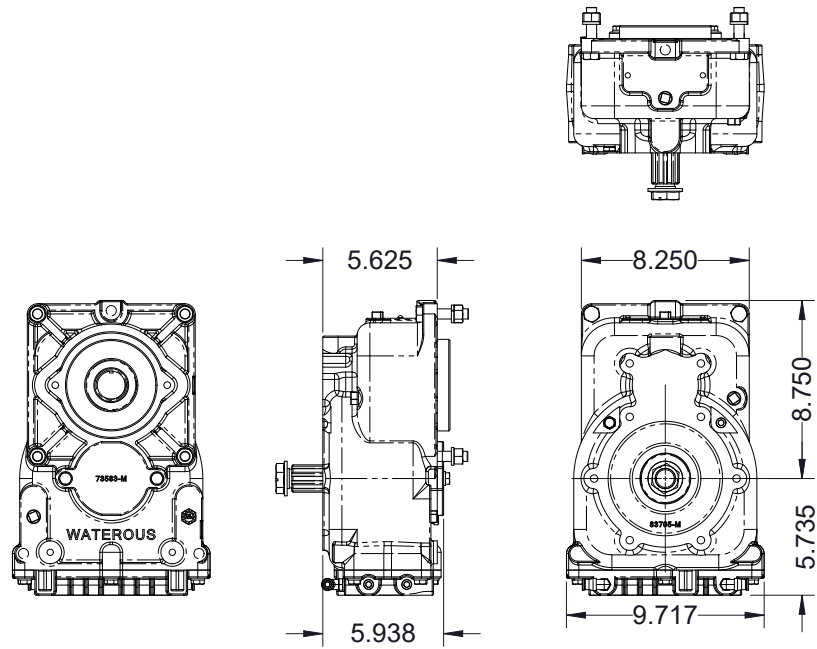

Aluminum K

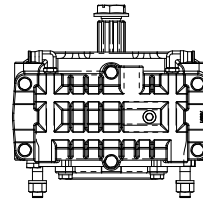

## Iron K-Transmission Dimensions

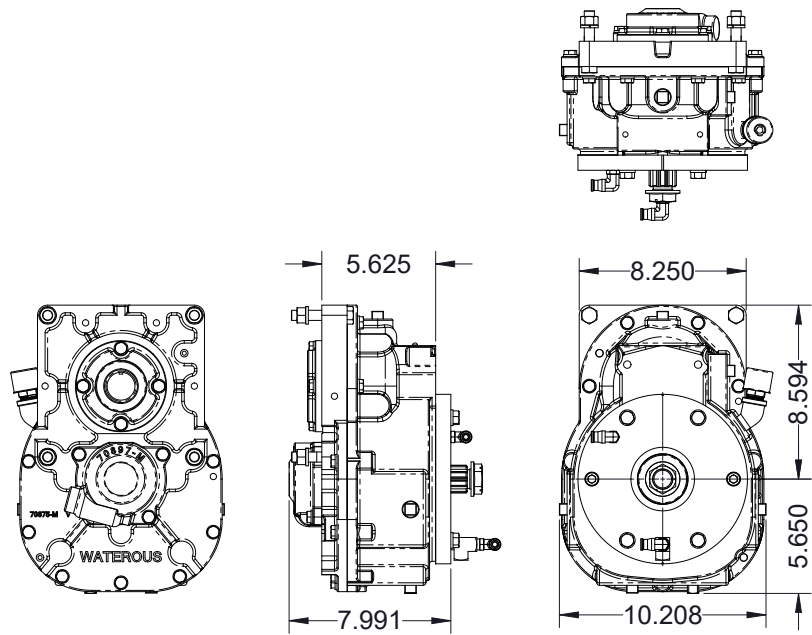

Iron K

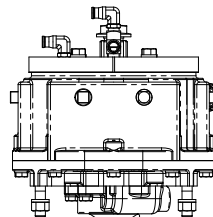

# K-Transmission

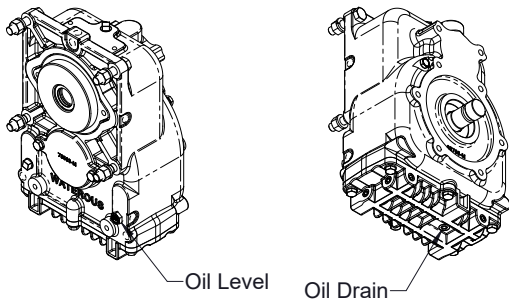

Vertical

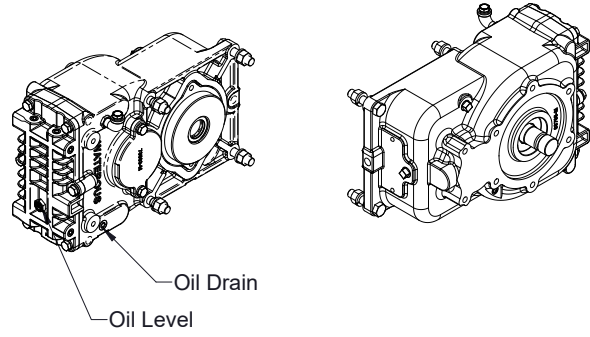

Right

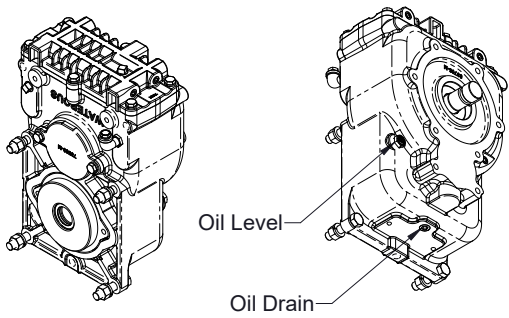

Inverted

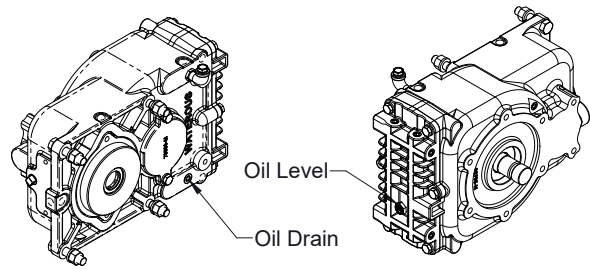

Left