

WATEROUS

Contact Waterous for more information
(651) 450-5234, option 3

Technical Bulletin No. 131

New Intake Pressure Relief Valve

The new **Intake-Pressure Relief Valve** is available on **January 1, 2020**. The simplified design builds on the reliability of previous versions, with a set-it and forget-it operation. Order the valve pre-installed on select Waterous pumps, or separately for your current application. Contact Waterous for more information.



Factory Installed Version

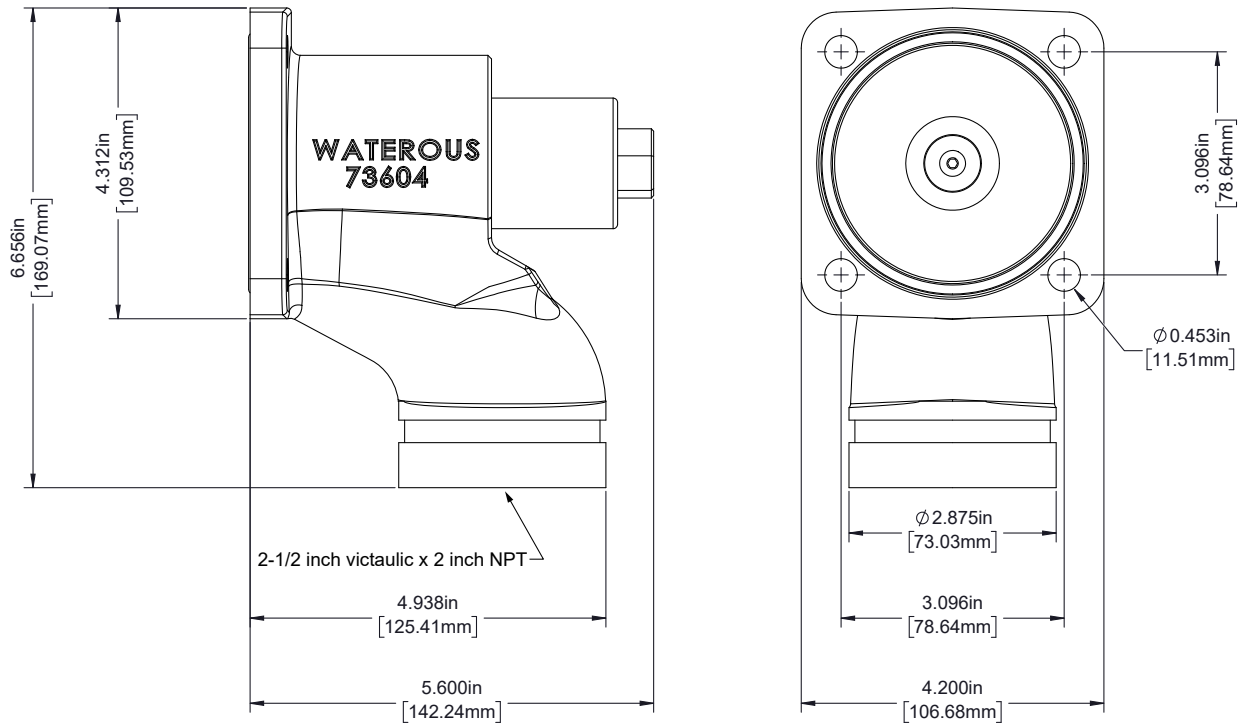

Separately Mounted Version

