



Document Number	Issue Date	Rev. Date
DPL82078-1	01/11/96	02/02/12

Dimensional Drawings Heavy Duty T Transmission

Index:

Description	See Page
Two-Gear without Hydraulic Clutch, Direct Engine Mount	2
Available Mounting Positions	3

AVAILABLE AS FOLLOWS:

DRIVE	TYPE	MODEL	AVAILABLE BELLHOUSINGS		AVAILABLE RATIOS	AVAILABLE FOR PUMP MODELS:	
			HOUSING ADAPTER	FOR CLUTCH NUMBER		PUMP MODEL	IMPELLER SHAFT TYPE
DIRECT ENGINE MOUNT TO SAE FLYWHEEL FOR DRIVING RING-TYPE OVER CENTER CLUTCH PER SAE J620	TWO GEAR WITHOUT HYDRAULIC CLUTCH	HEAVY DUTY T (HDT)	SAE 2, 3 OR 4	10	1.16, 1.38, 1.56, 1.65, 1.76, 1.88, 2.14, 2.45	CGV, CGVR, CXV	ONE-PIECE
			SAE 2 OR 3	11-1/2			

NOTE: AVAILABLE WITH EITHER CLOCKWISE OR COUNTERCLOCKWISE INPUT ROTATION

SAE BELLHOUSING				D	SAE FLYWHEEL		OPTIONAL DRIVE PLATE	
SIZE	A	B	C		CLUTCH NUMBER	E	PART NUMBER	TORQUE RATING
2	17.625 447.68	19.250 488.95	18.375 466.73	8.250 209.55	10	2.12 53.85	V 2462	850 FT-LB 1152.6 JOULES
	3	16.125 409.58	17.750 450.85	16.875 428.63				
4	14.250 361.95	15.875 403.23	15.000 381.00					
2	17.625 447.68	19.250 488.95	18.375 466.73	8.250 209.55	11-1/2	1.56 39.62	V 2463	
3	16.125 409.58	17.750 450.85	16.875 428.63	7.250 184.15				

8X 3/8-16 UNC-2B TAPPED HOLES IN FLYWHEEL, USE CLASS 8 SCREWS

FLYWHEEL FOR DRIVING-RING TYPE OVER CENTER CLUTCH PER SAE J620

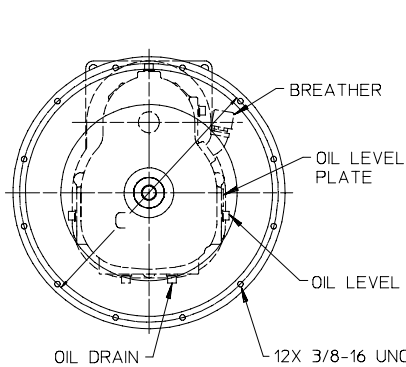

12X 3/8-16 UNC-2B TAPPED HOLES IN FLYWHEEL HOUSING, USE CLASS 5 SCREWS

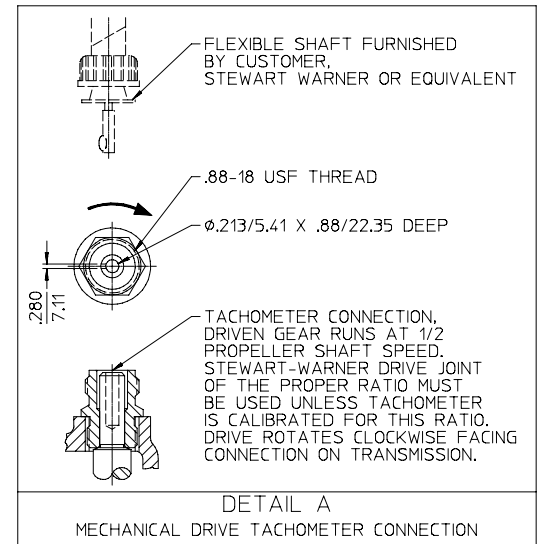
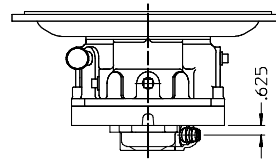
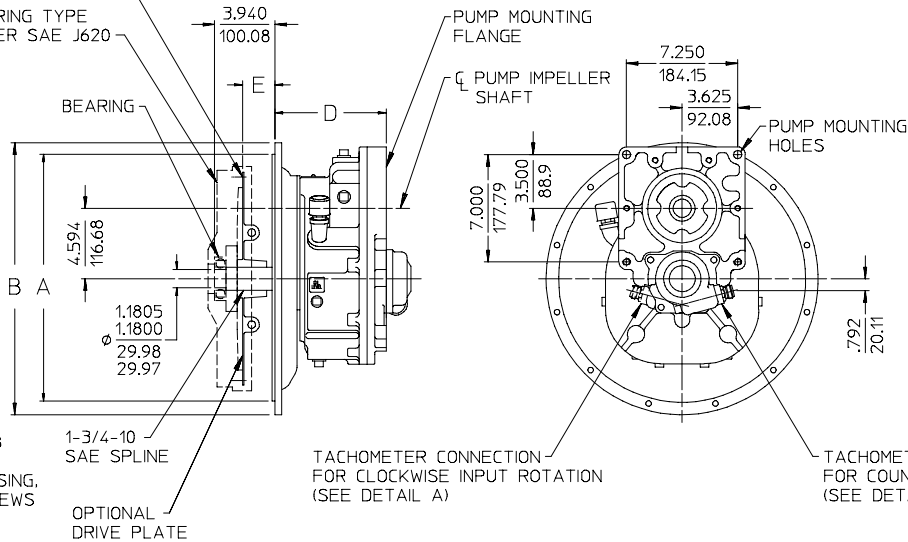

ALL DIMENSIONS SHOWN IN INCH/MILLIMETER
(INCH / MILLIMETER)

HEAVY DUTY T TRANSMISSION
TWO-GEAR WITHOUT HYDRAULIC CLUTCH, DIRECT ENGINE MOUNT

HEAVY DUTY T
DPL82078-1
WATEROUS COMPANY
SOUTH ST. PAUL, MN 55075
PAGE 2 OF 3

AVAILABLE MOUNTING POSITIONS
AS VIEWED FROM INPUT (BELLHOUSING) SIDE OF TRANSMISSION

