

Issued: 11/26/91

Revised: 02/08/96

W A T E R O U S

WATEROUS COMPANY

SOUTH ST. PAUL, MINNESOTA

HEAVY DUTY KC TRANSMISSION ASSEMBLY

REF NO.	DESCRIPTION	REF NO.	DESCRIPTION
T2	Pump serial plate	T38	Impeller shaft or driven shaft spacer
T3	Driven gear	T39	Oil seal sleeve
T4	Oil seal housing gasket	T40	Oil seal housing
T8	Bearing housing gasket	T41	Bearing lock nut
T10	Oil seal housing	T46	Shaft nut
T13	Gear case subassembly	T47	Bearing lock washer
T14	Dowel pin, 3/8 x 1 in.	T48	Cotter pin, 1/8 x 1-3/4 in., SS
T15	Drive gear	T49	O-ring, 3-1/4 x 3-1/2 in.
T17	Breather, 1/2 NPT	T50	Oil seal, 1-5/8 x 2-1/2 in.
T18	Magnetic drain plug, 1/2 in.	T52	Ball bearing
T19	Hex hd screw, 3/8-16 x 1-1/4 in., Grade 5	T53	Ball bearing
T20	Hex hd screw, 7/16-14 x 1-1/4 in., Grade 5	T54	Ball bearing
T21	Hex hd screw, 1/2-13 x 1-1/4 or 1-1/2 in., Grade 5	T56	Suspension pin, 1 x 2-5/8 in.
T22	Hex hd screw, 1/2-20 x 2-1/2 in., Grade 5, zinc plated	T57	Suspension bracket
T23	Hex nut, 1/2-20	T59	Cotter pin, 5/16 x 2-1/2 in.
T24	Oil seal, 1-5/8 x 2-7/16 in.	T67	Oil level plate
T25	Lock washer, 3/8 in.	T69	Street elbow, 45° x 1/2 NPT
T26	Lock washer, 7/16 in.	T92	Hex hd screw, 3/8-16 x 1 in.
T27	Lock washer, 1/2 in.	T93	Ball bearing
T28	Retaining ring	T96	Driven shaft
T31	Pipe plug, 1/2 NPT	T98*	V-ring flinger (used prior to 8/26/93) Sealing boot (used after 8/26/93)
T32	Drive screw, no. 6 x 1/4 in.	T99	Square key, 5/16 x 1-5/16 in.
T37	Impeller shaft spacer	T111	Input elbow, LH or RH thread

PLEASE NOTE

WHEN ORDERING PARTS PLEASE SUPPLY PUMP SERIAL NUMBER

SPL81781

PAGE 1 OF 6

W A T E R O U S

WATEROUS COMPANY

SOUTH ST. PAUL, MINNESOTA

HEAVY DUTY KC TRANSMISSION ASSEMBLY

REF NO.	DESCRIPTION	REF NO.	DESCRIPTION
T112	Retaining ring	T121	Magnetic pickup
T113	Rotating union, LH or RH thread	T123	O-ring, 5/8 x 3/4 in.
T115	Drive clutch cup	T124	Oil seal, 1-1/2 x 2-3/8 in.
T116	Flat hd socket screw, 3/8-16 x 1 in.	T125	Tube connector, 1/8 x 1/4 in.
T117	Drive shaft spacer	T126	Clutch plate and O-ring set
T118	Ball bearing	T127	Shaft and clutch assembly (includes 1/2 x 1-1/2 in. sq. key)
T119	Drive shaft spacer		
T120	Drive shaft spacer		

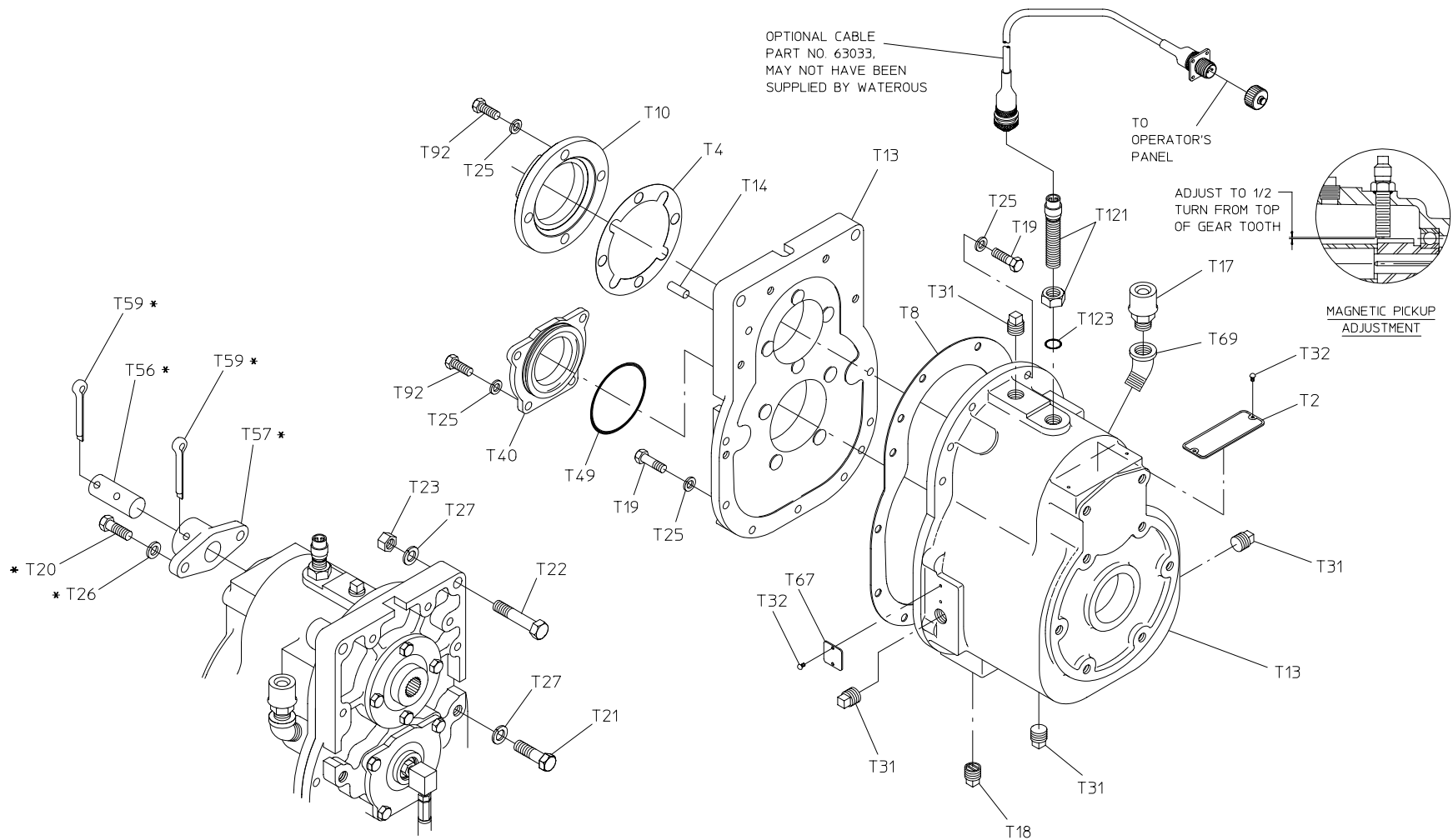

PUMP MOUNTING HARDWARE

* PART OF OPTIONAL TRANSMISSION
MOUNTING KIT

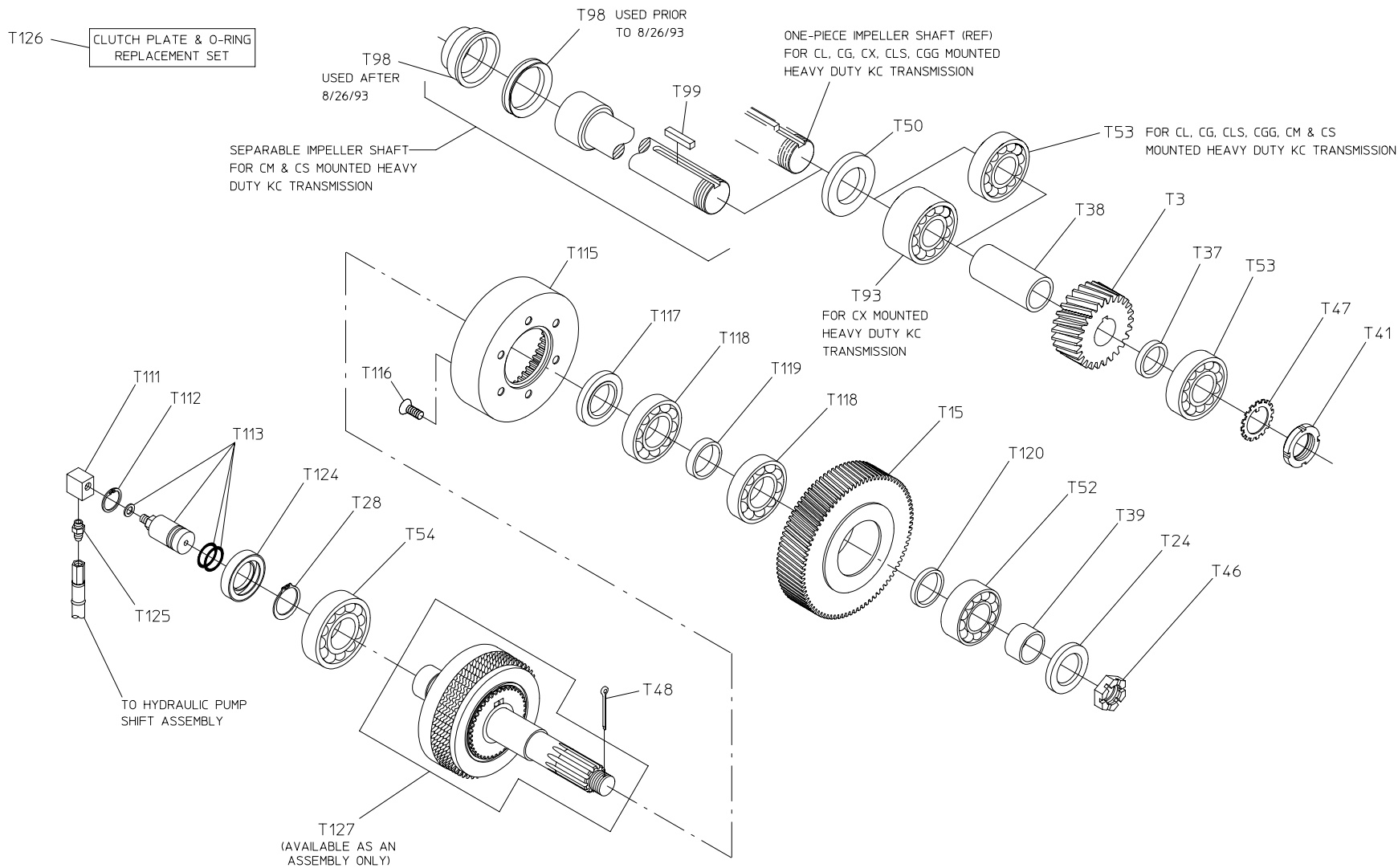

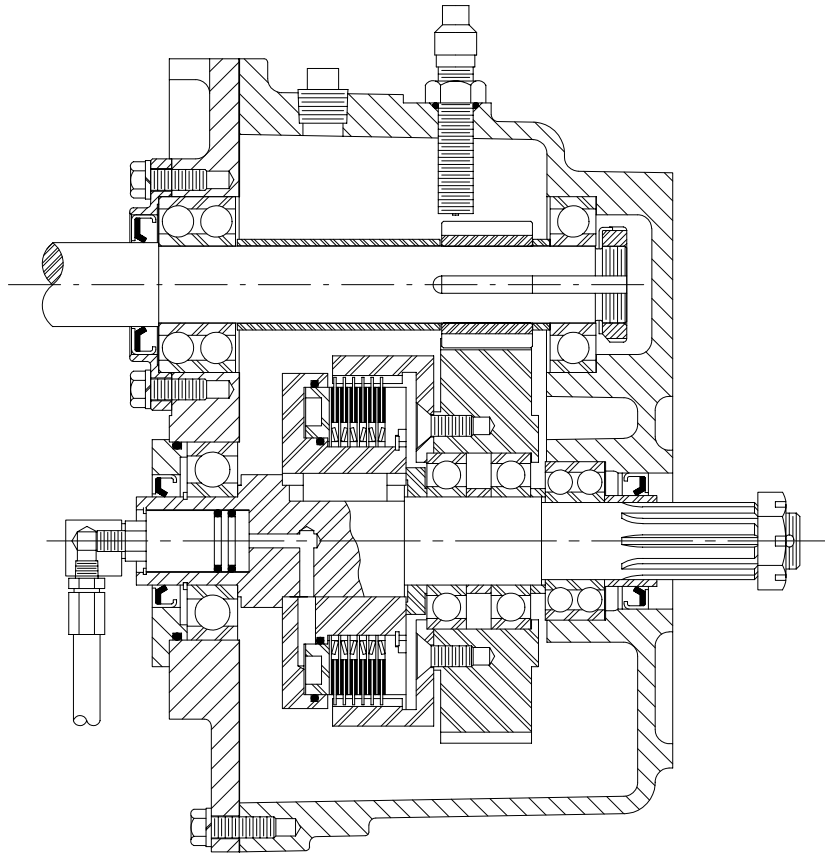

CROSS SECTION VIEW
MODEL CX MOUNTED HEAVY DUTY KC TRANSMISSION

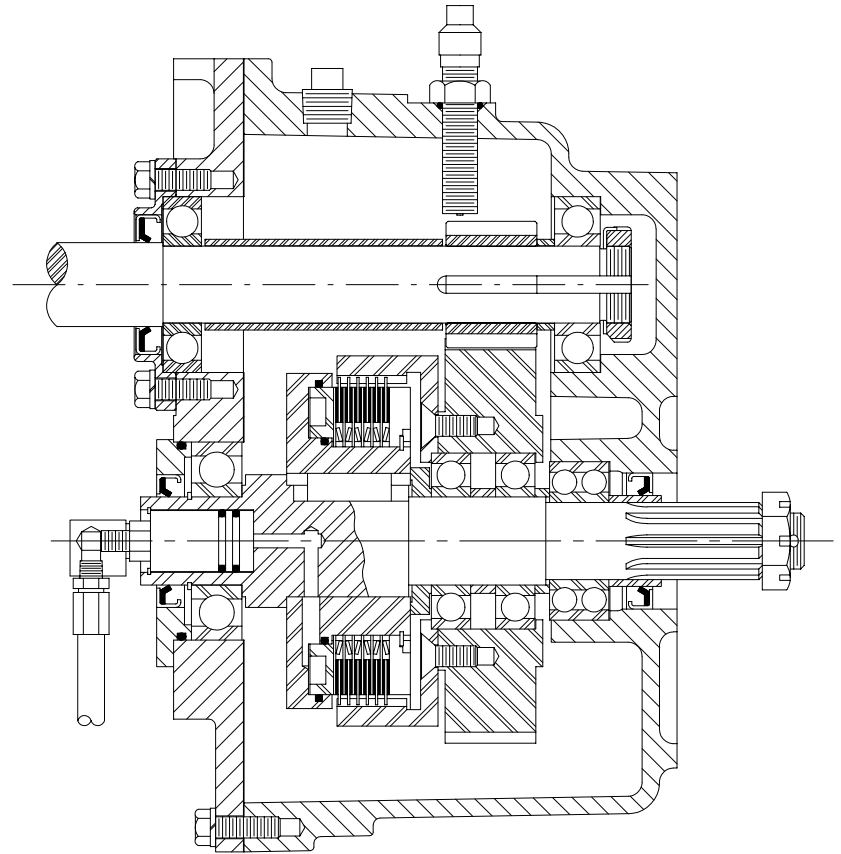

CROSS SECTION VIEW
MODEL CL/CG, CLS/CGG MOUNTED HEAVY DUTY KC TRANSMISSION

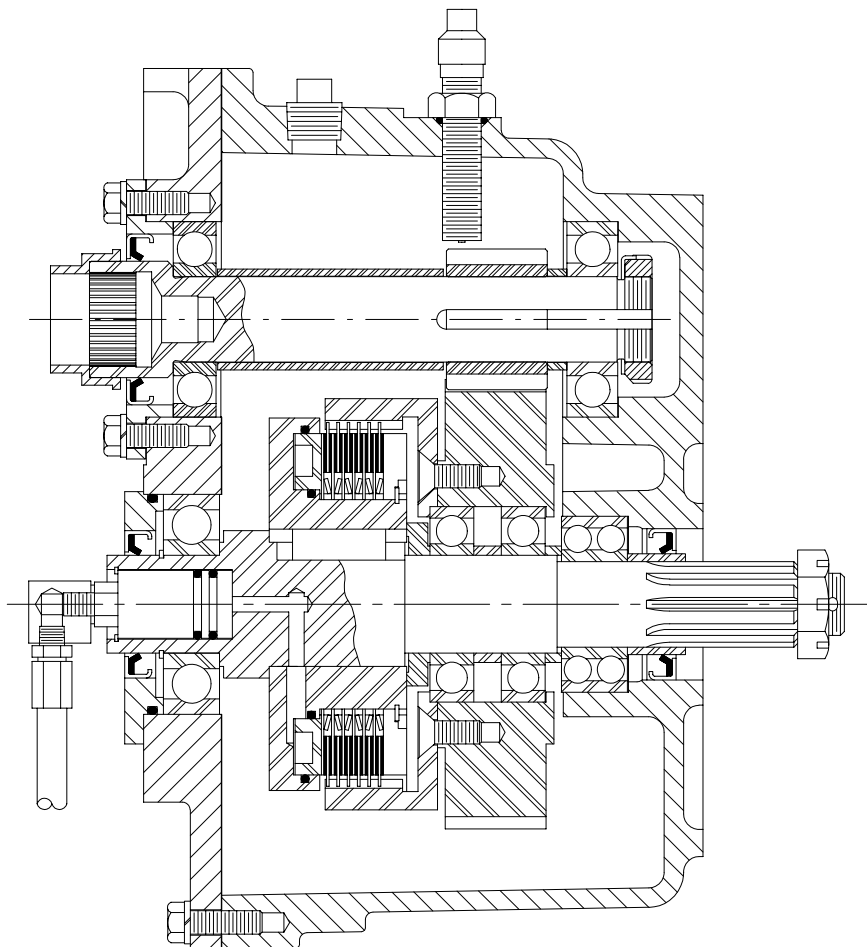

CROSS SECTION VIEW
MODEL CM/CS MOUNTED HEAVY DUTY KC TRANSMISSION